



US 20100134964A1

(19) **United States**
(12) **Patent Application Publication**
Smith et al.

(10) **Pub. No.: US 2010/0134964 A1**
(43) **Pub. Date: Jun. 3, 2010**

(54) **ELECTRONIC DEVICE**

Related U.S. Application Data

(75) Inventors: **Renato L. Smith**, Chicago, IL (US); **Attila J. Bendeguz**, Austin, TX (US); **Shen-Wei Hsieh**, Gueishan Township (TW); **Cheng-Chang Ku**, Shindian City (TW); **Cheng-Zhang Huang**, Keelung City (TW)

(63) Continuation-in-part of application No. 11/787,999, filed on Apr. 17, 2007, which is a continuation-in-part of application No. 11/315,830, filed on Dec. 22, 2005, which is a continuation-in-part of application No. 10/795,684, filed on Mar. 8, 2004, now Pat. No. 7,158,373.

Publication Classification

Correspondence Address:
Originatic LLC
28 E. Jackson Boulevard, Suite 10-C82
Chicago, IL 60604 (US)

(51) **Int. Cl.**
G06F 1/16 (2006.01)
(52) **U.S. Cl.** **361/679.2; 361/679.02; 361/679.6**

(57) **ABSTRACT**

(73) Assignee: **Originatic LLC**
(21) Appl. No.: **12/470,426**
(22) Filed: **May 21, 2009**

An electronic device having a main housing defining a cavity, a display screen supported by the main housing, and a motherboard positioned within the cavity behind the display screen. The electronic device has a keyboard assembly, camera assembly, and/or desktop stand assembly.

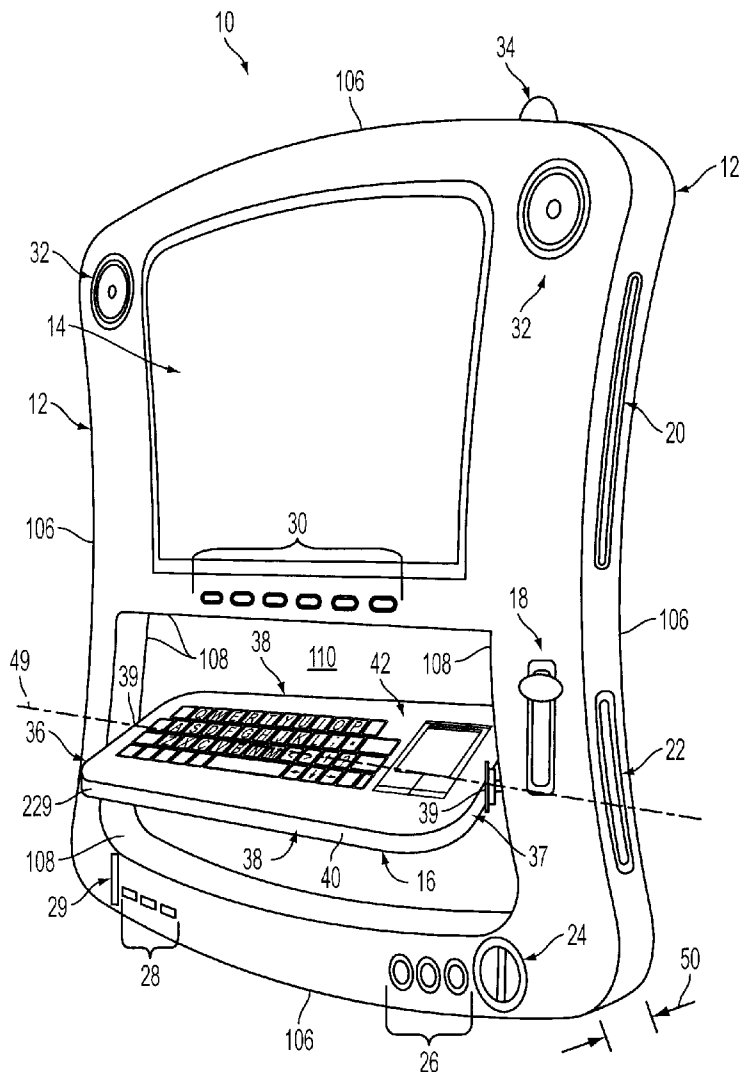

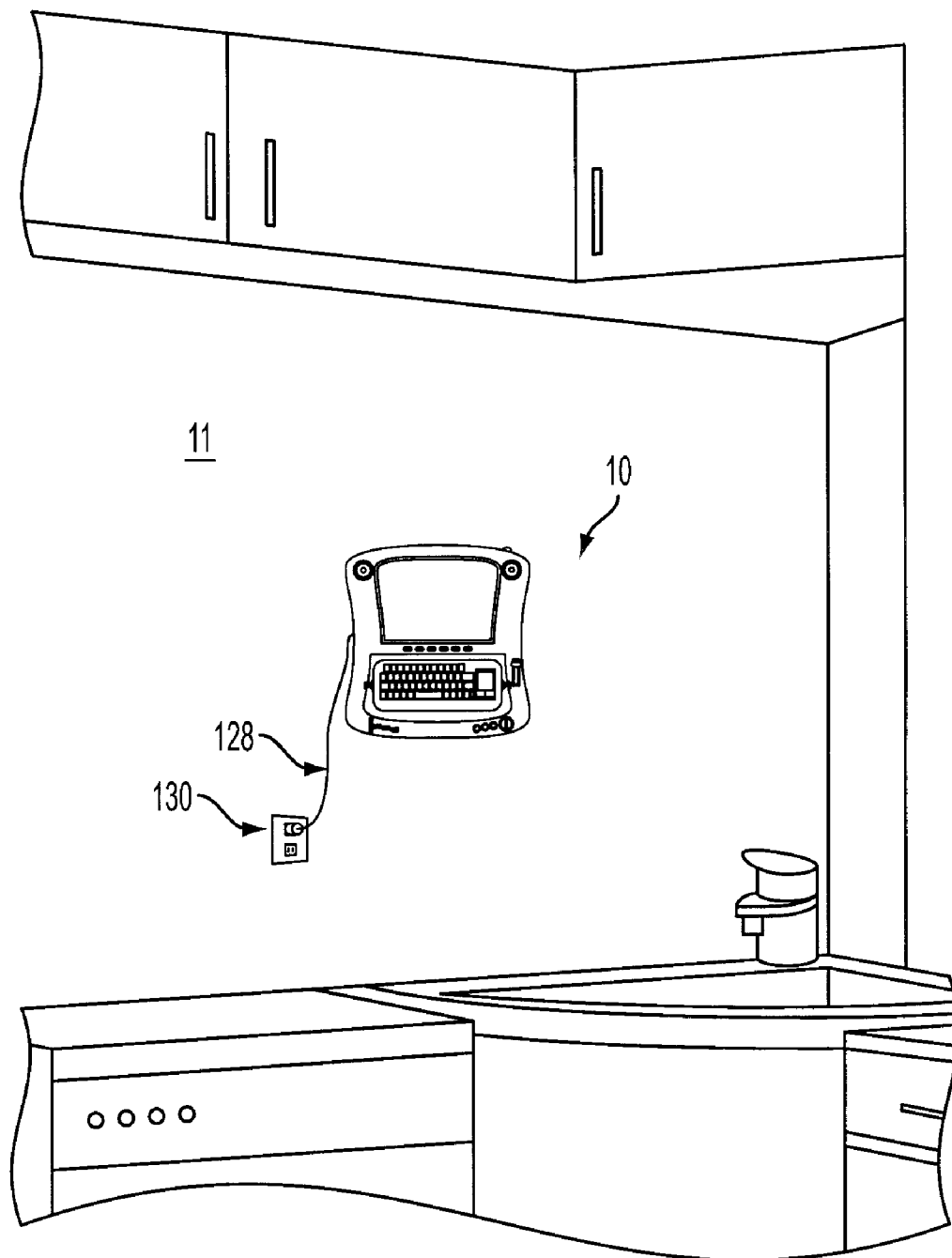

FIG. 1

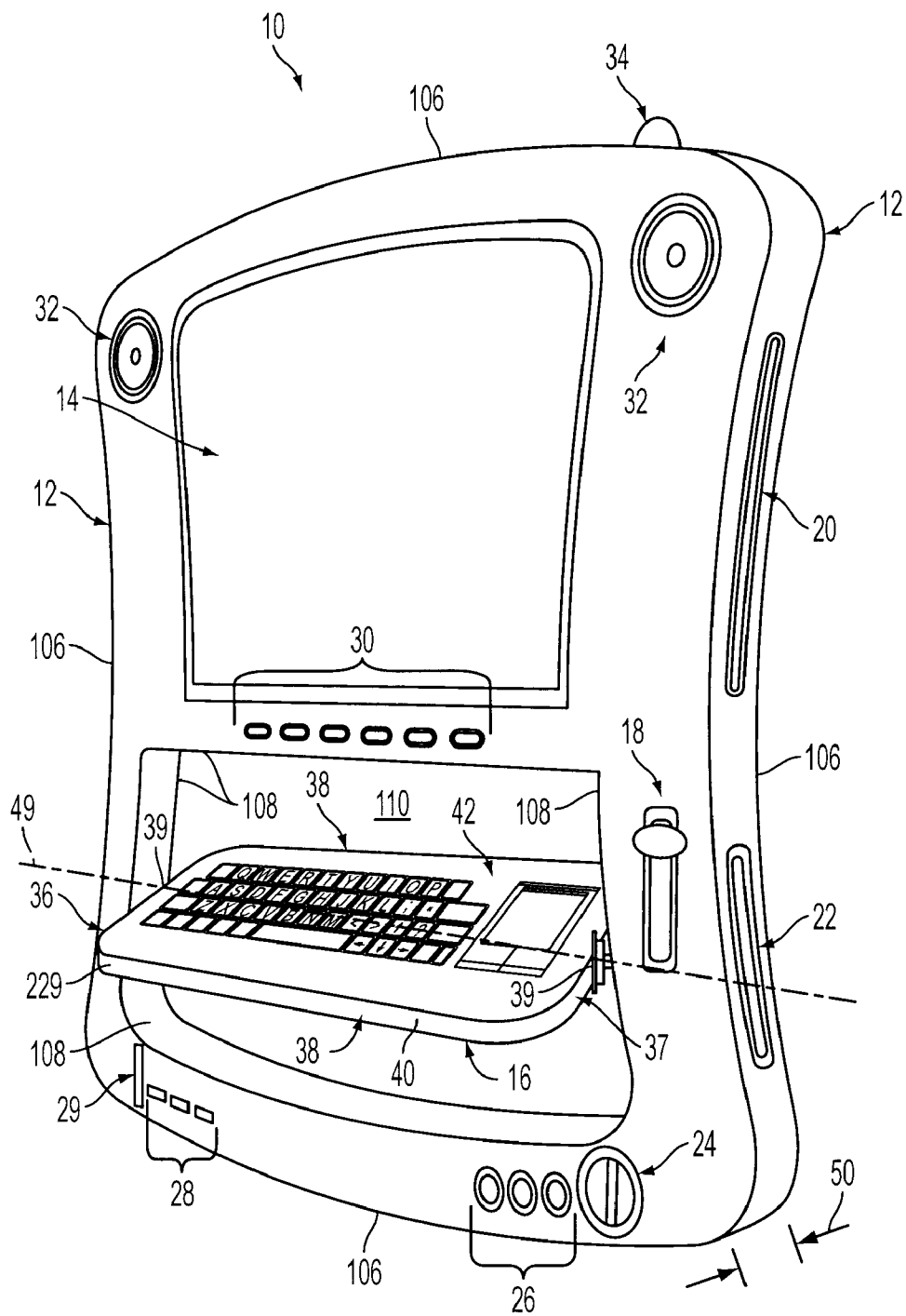

FIG. 2

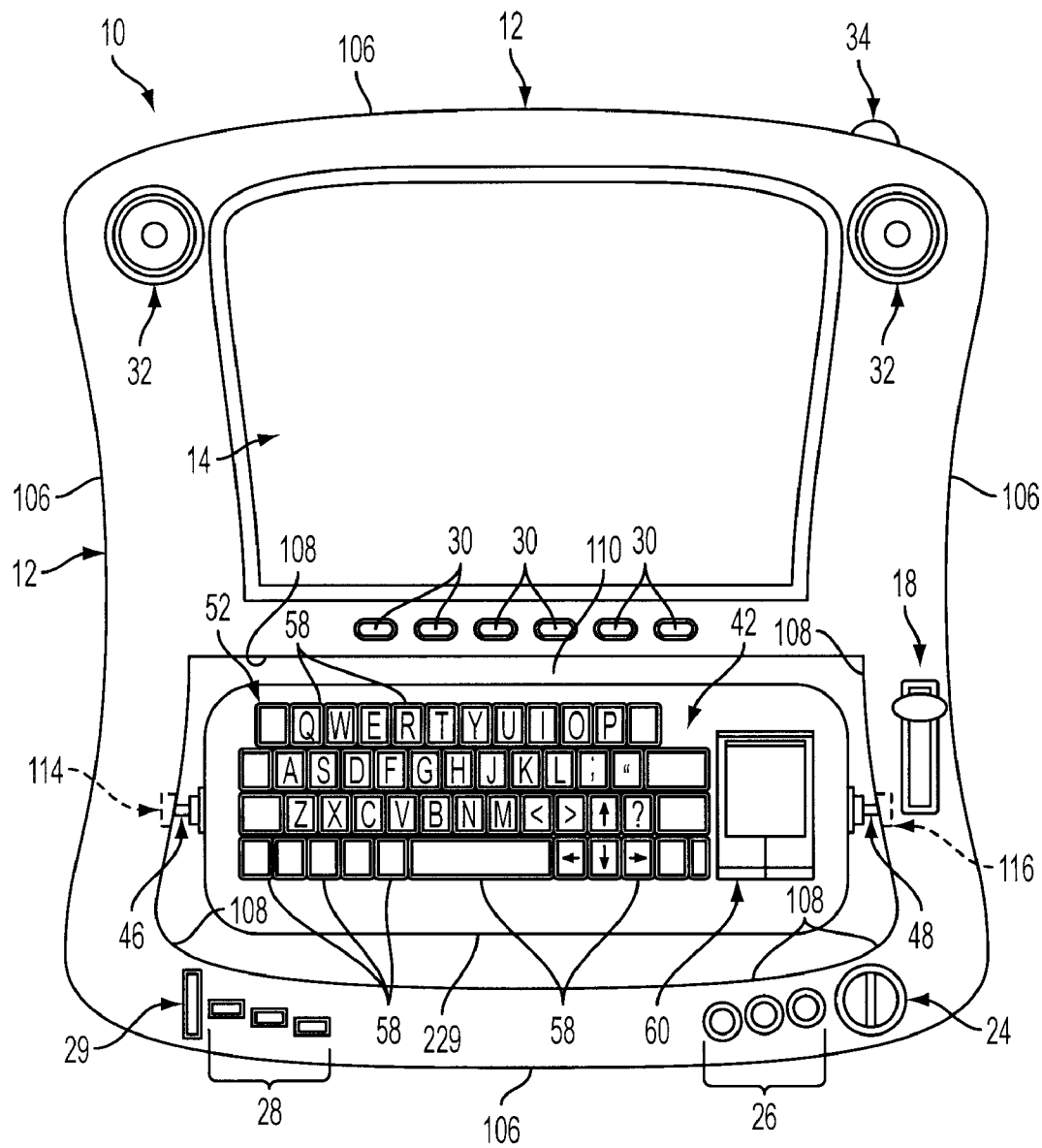

FIG. 3

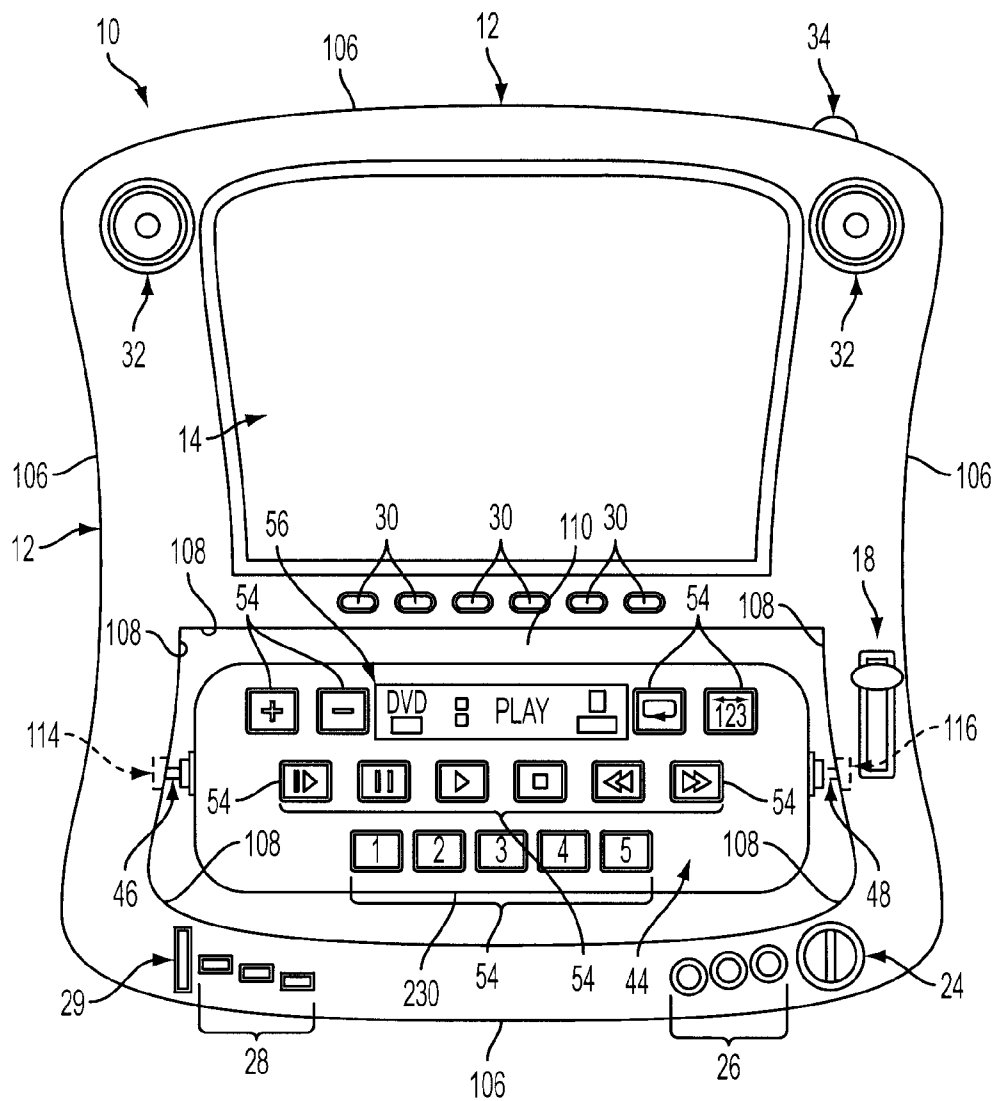

FIG. 4

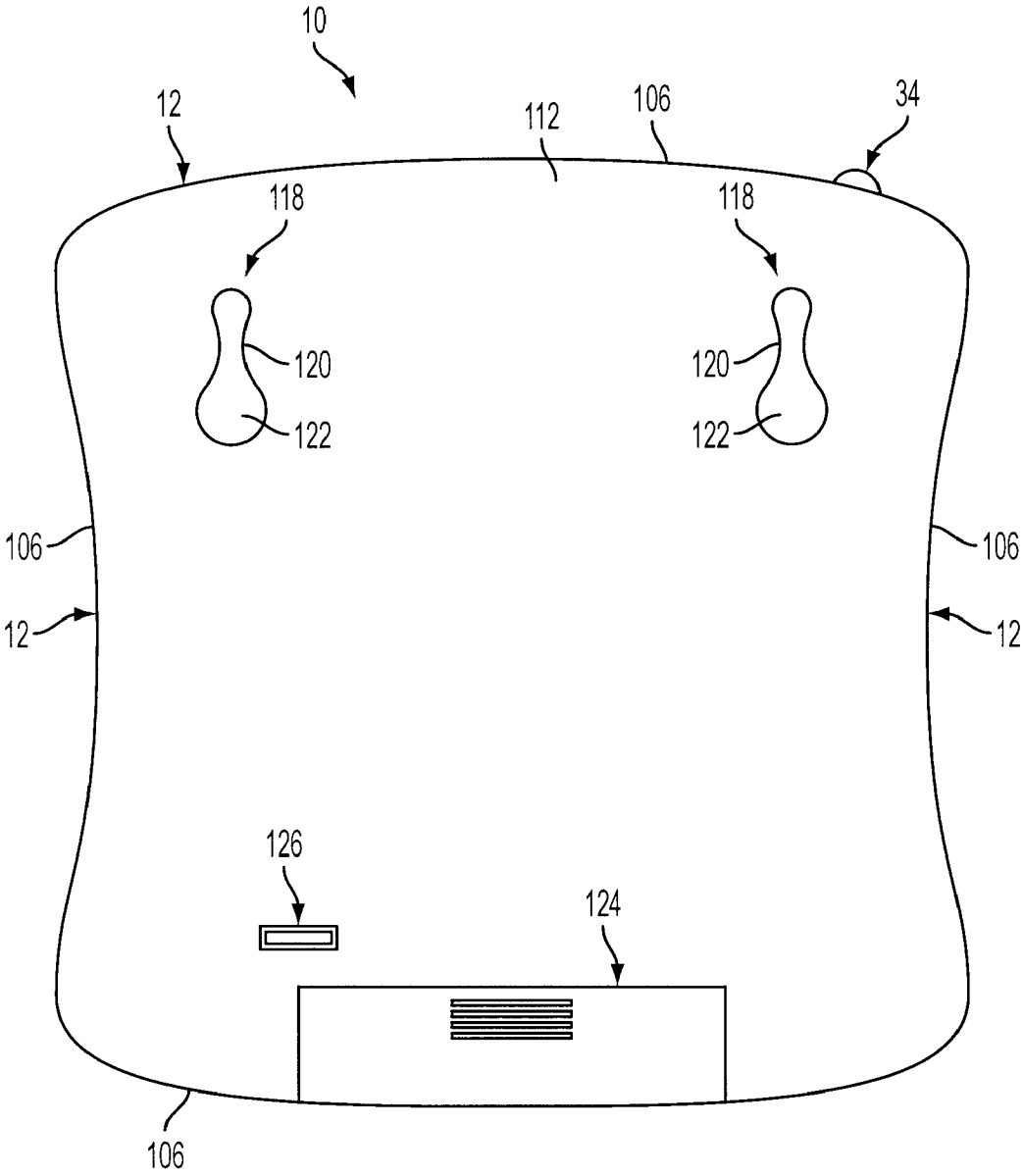

FIG. 5

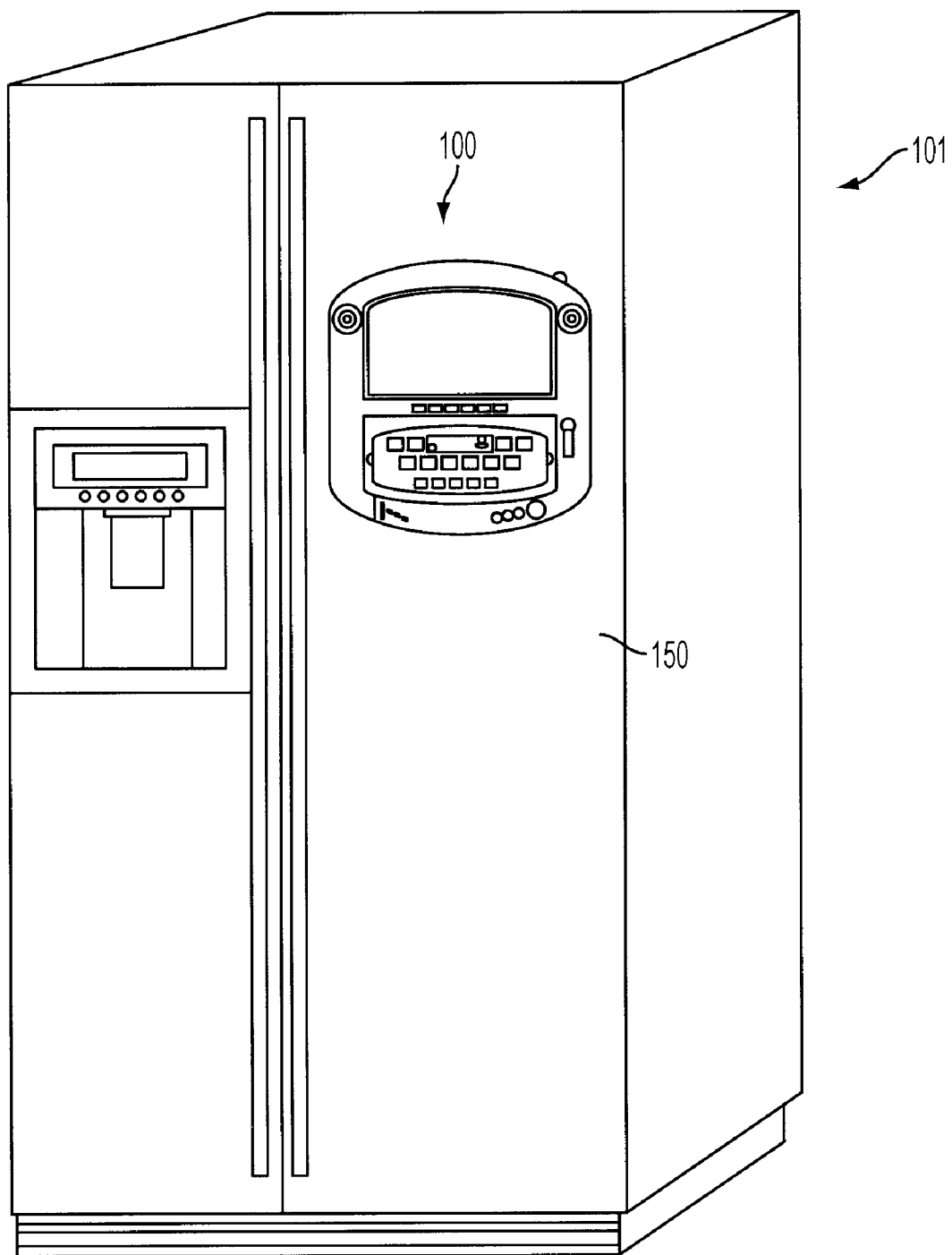

FIG. 6

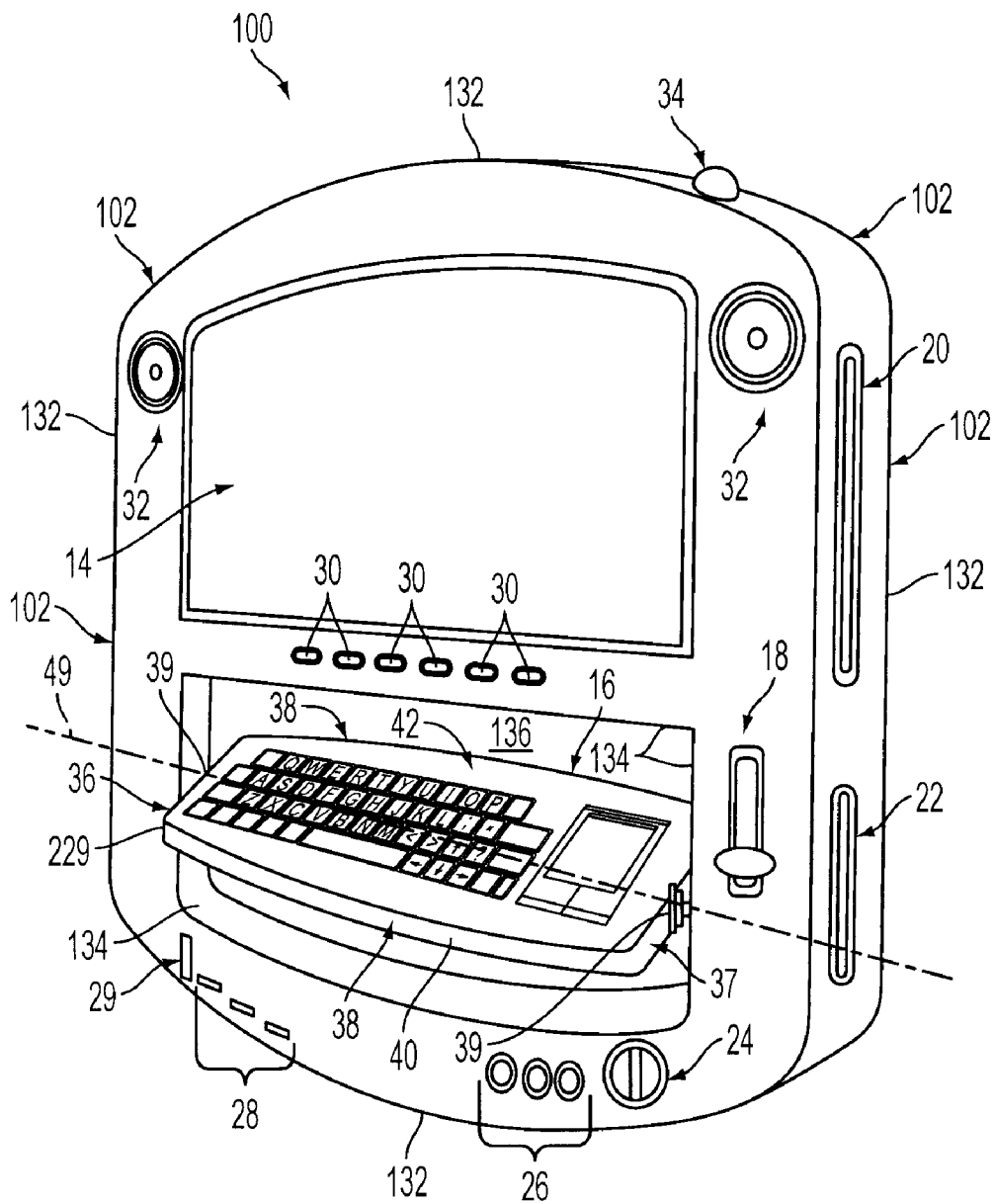

FIG. 7

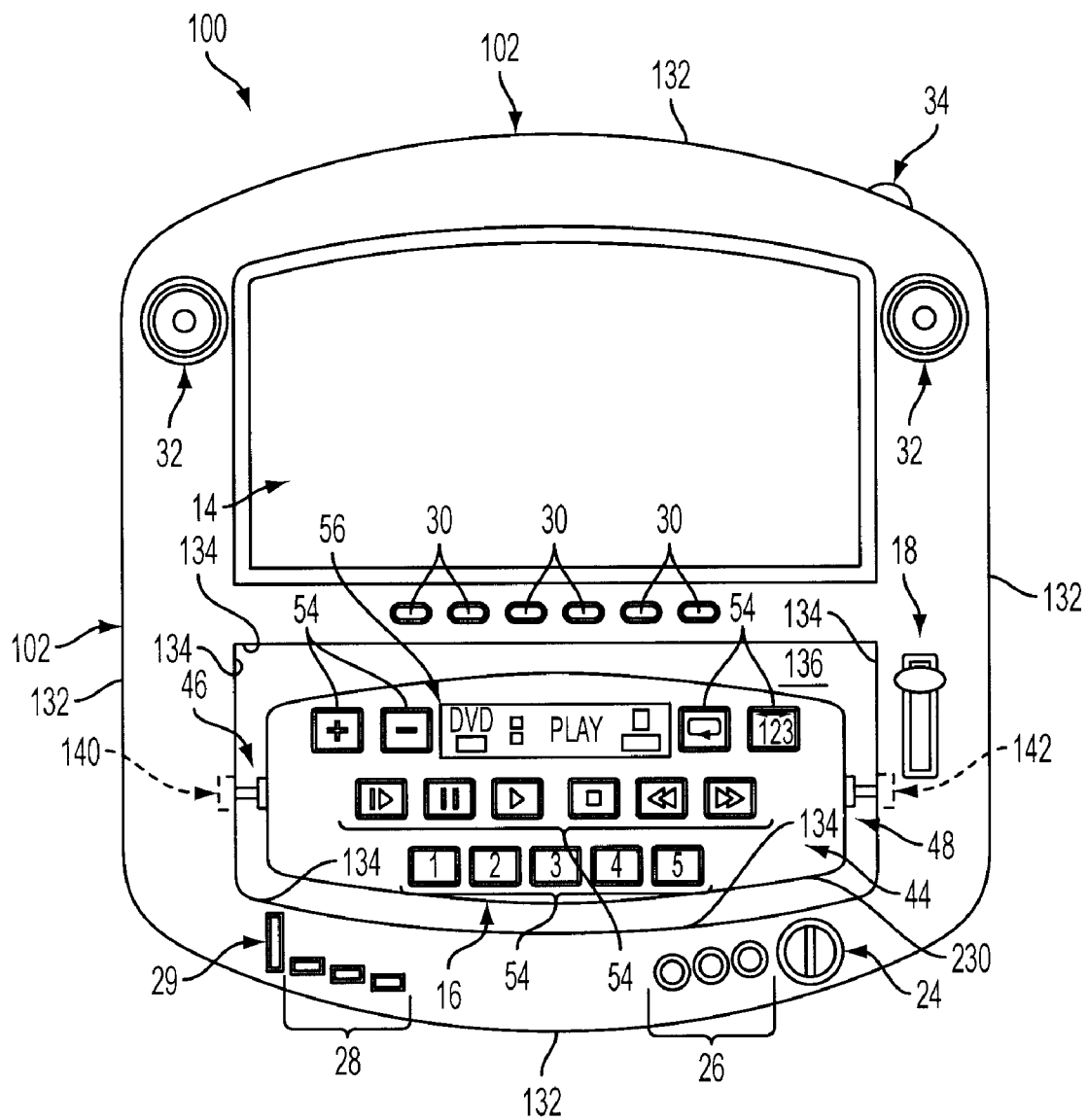

FIG. 8

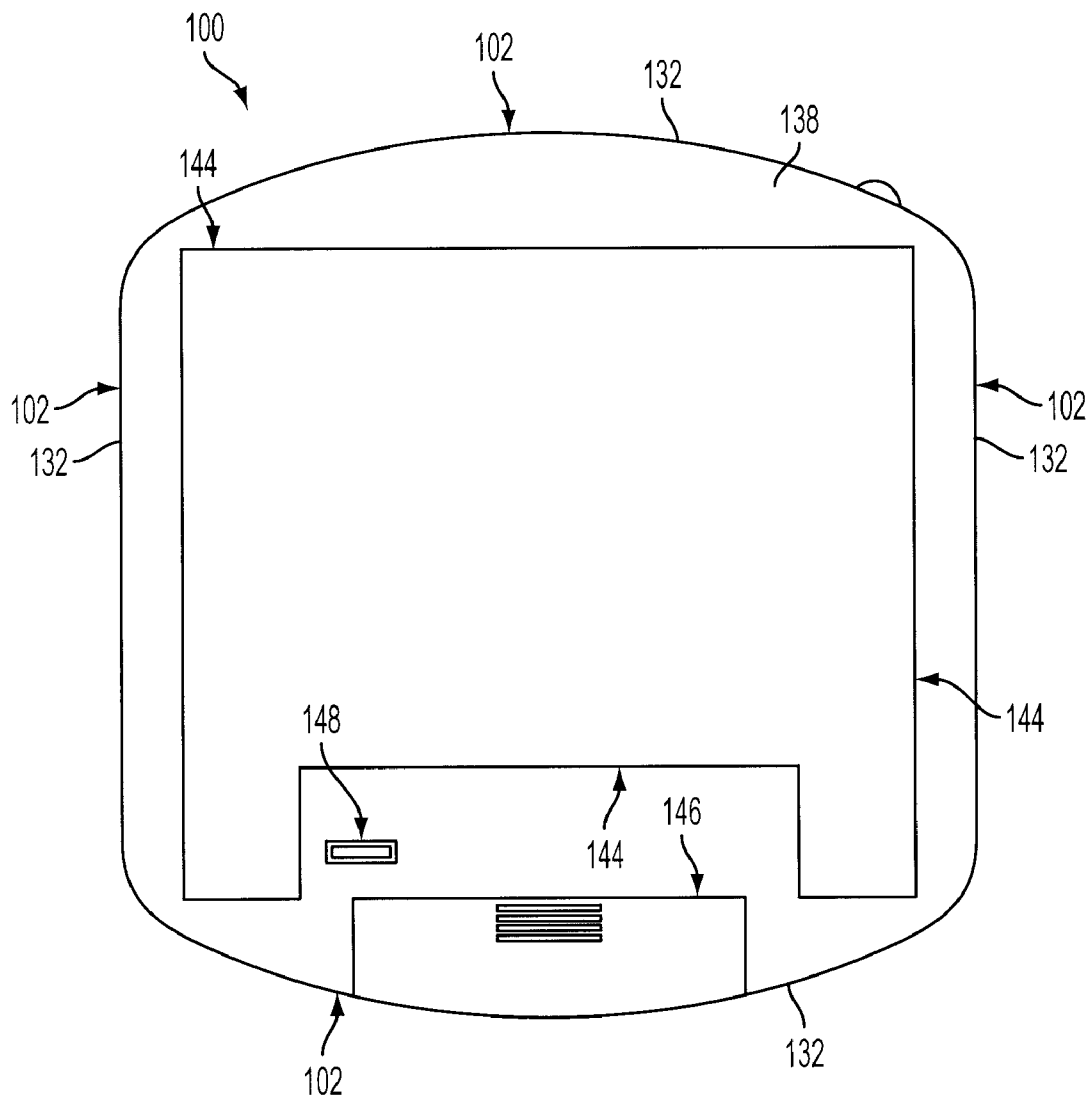

FIG. 9

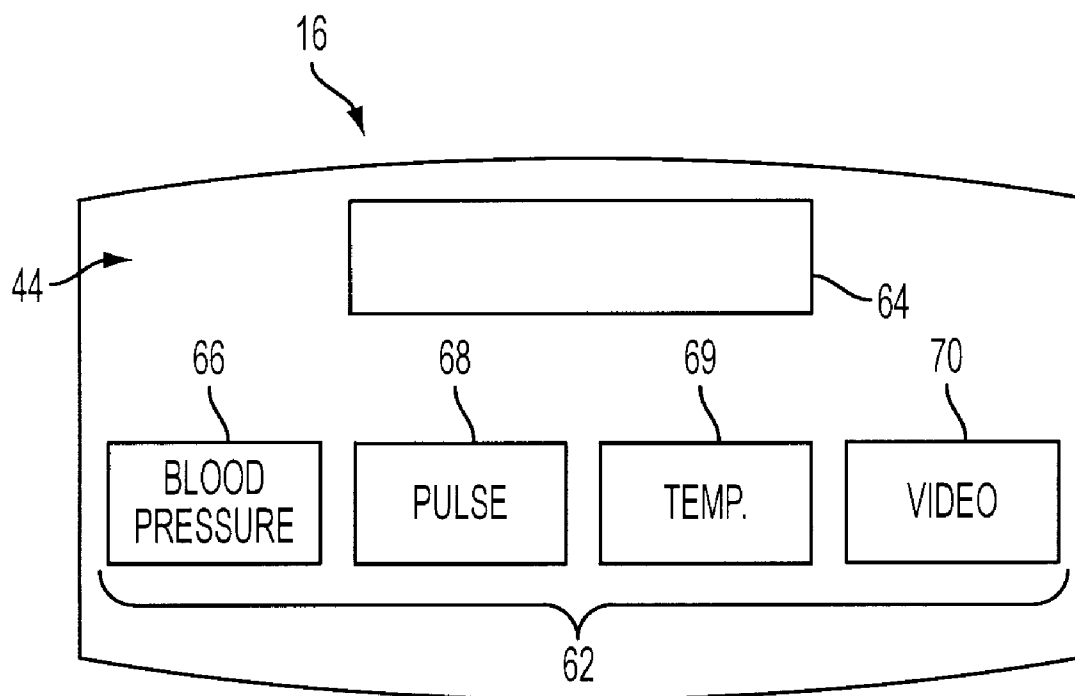

FIG. 10

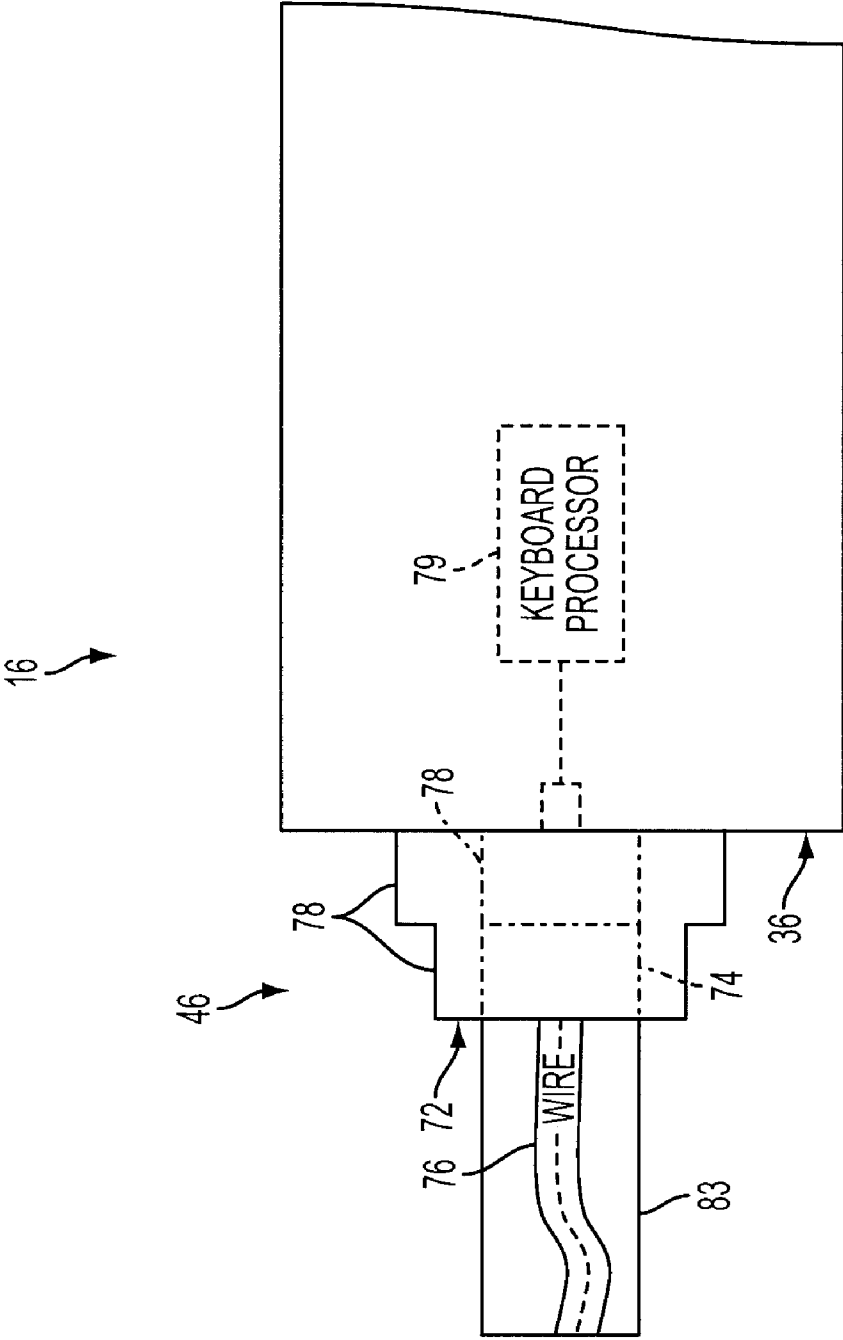

FIG. 11

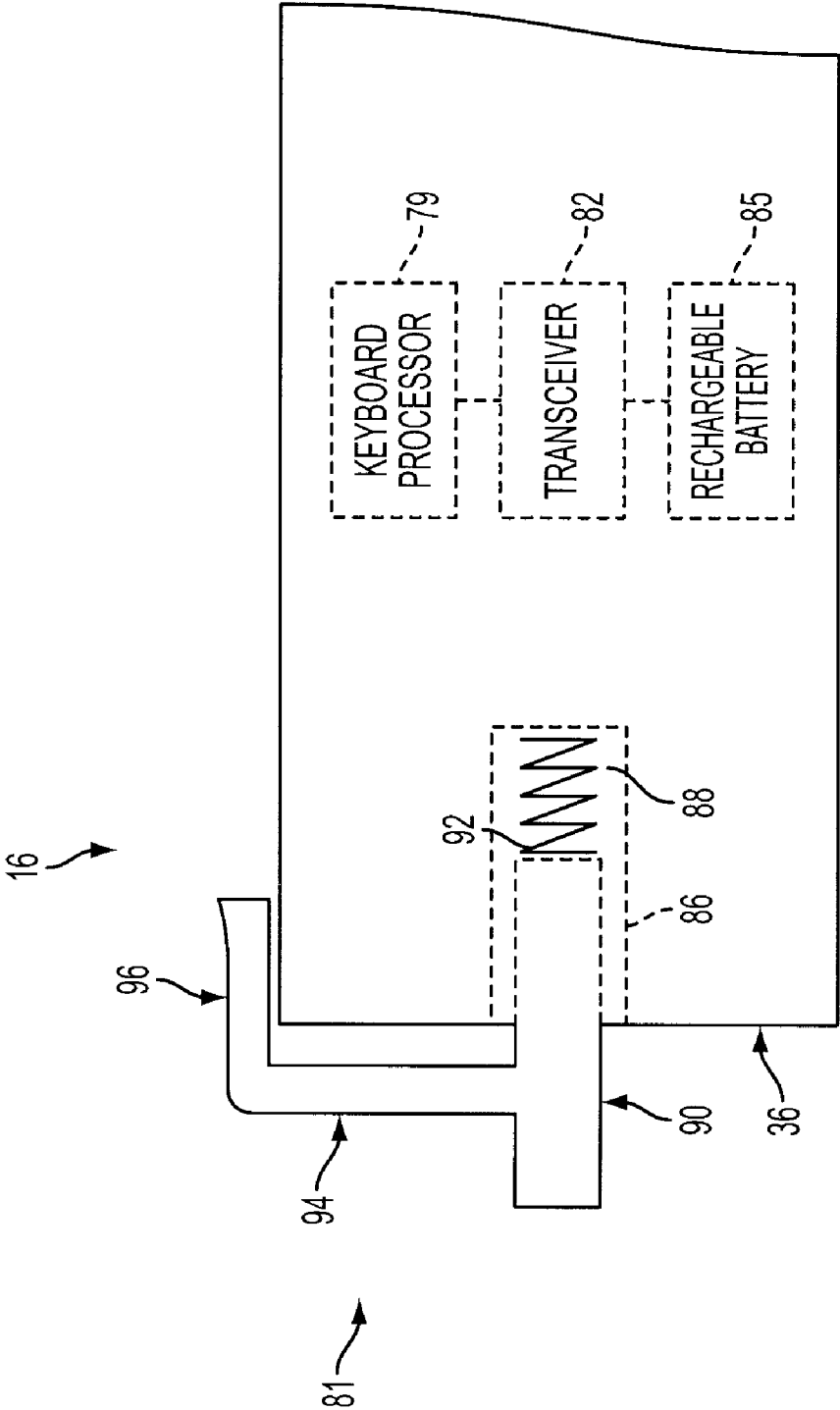

FIG. 12

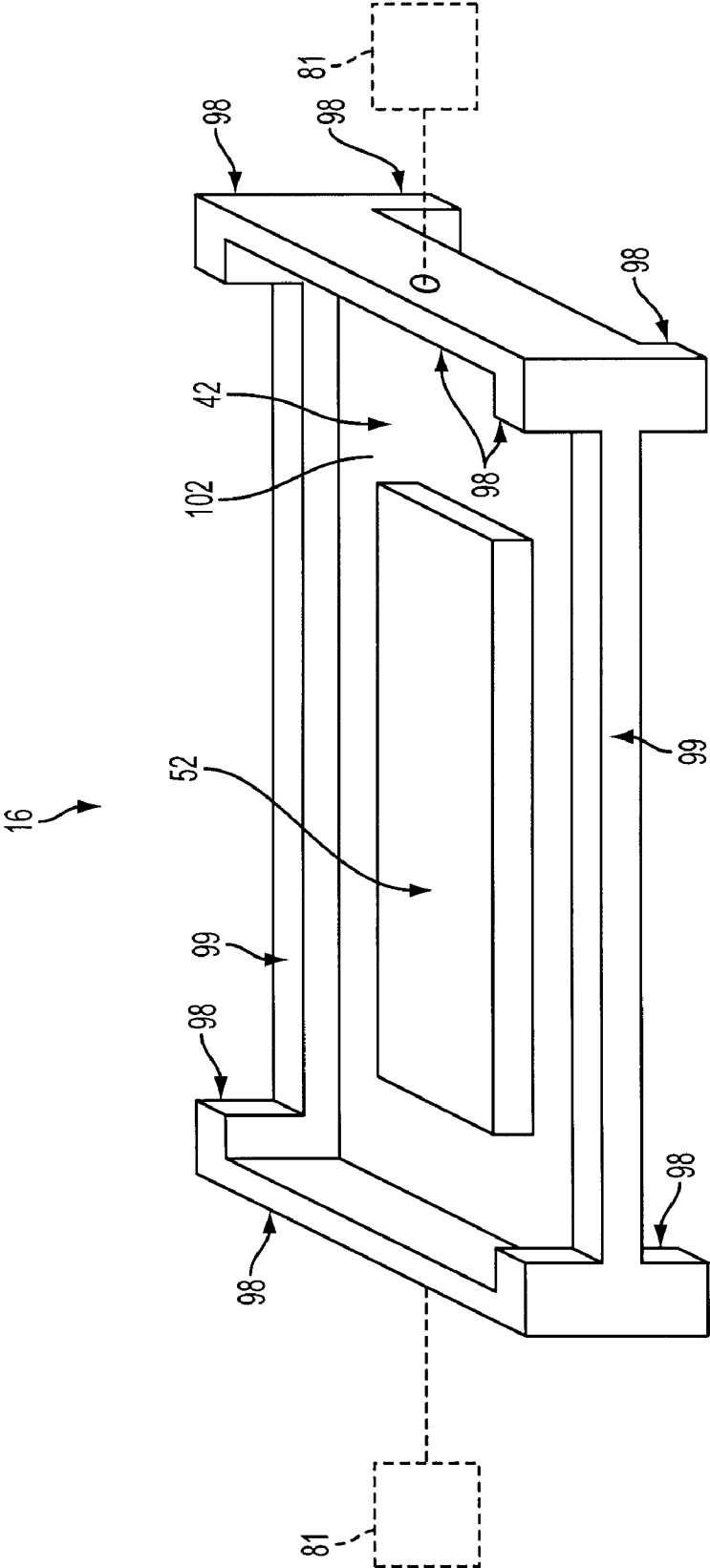

FIG. 13

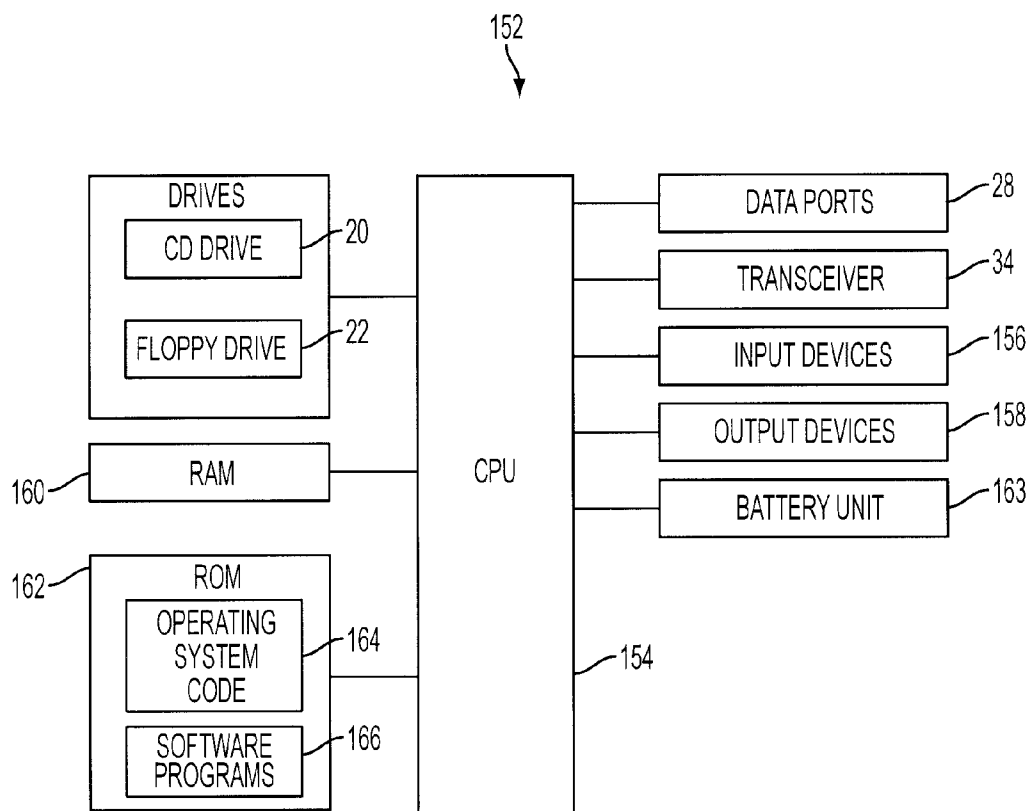

FIG. 15

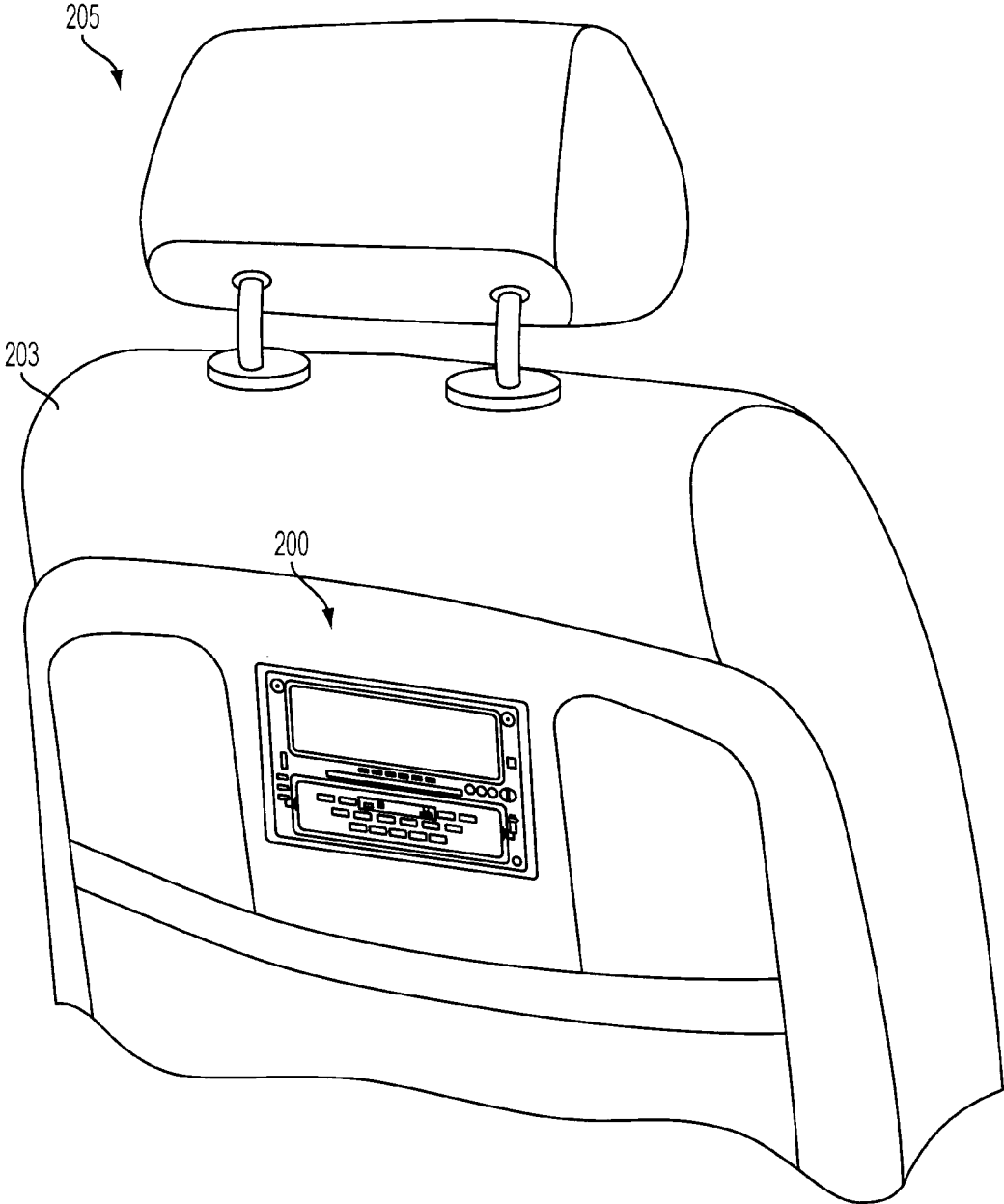

FIG. 16

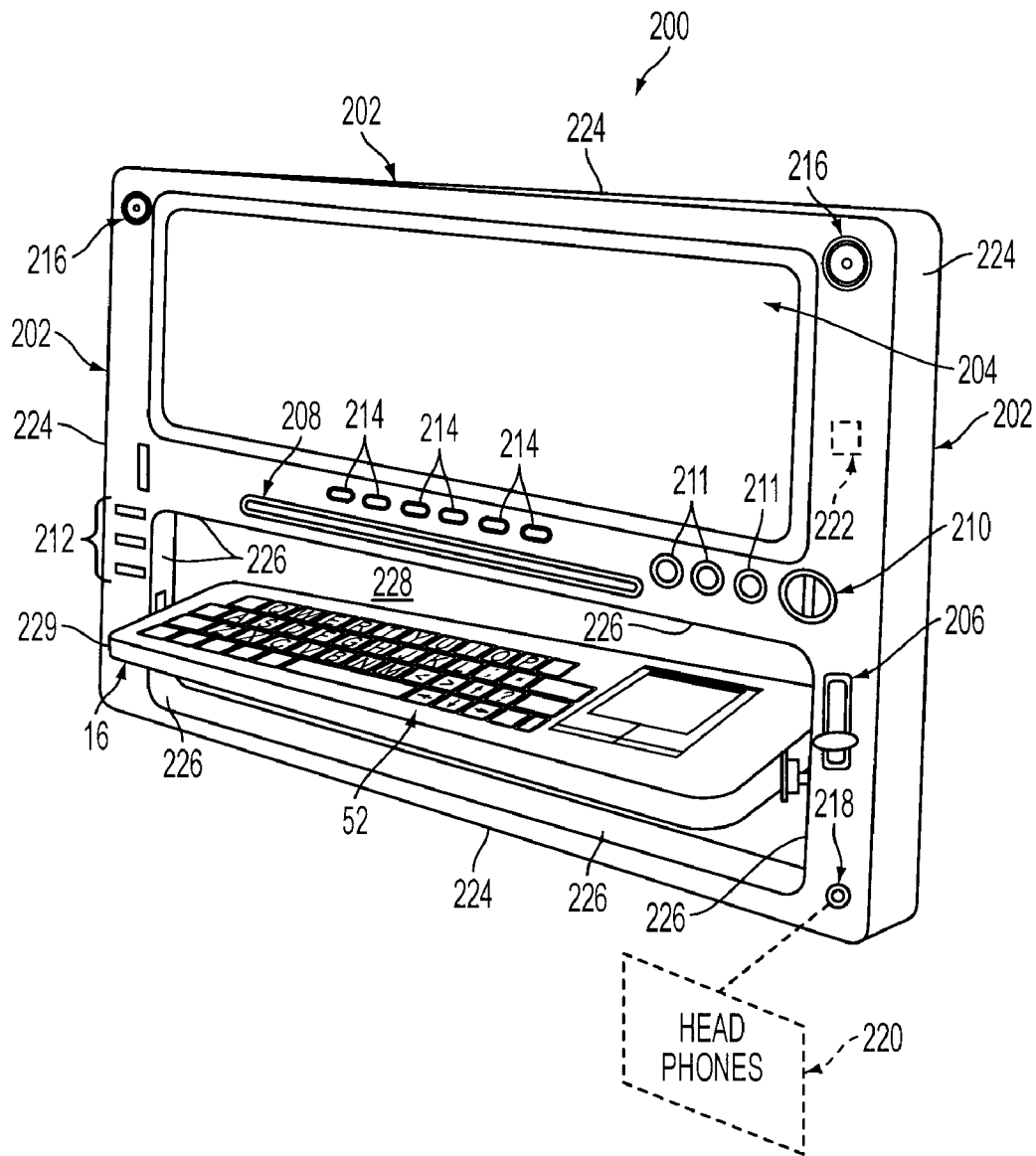

FIG. 17

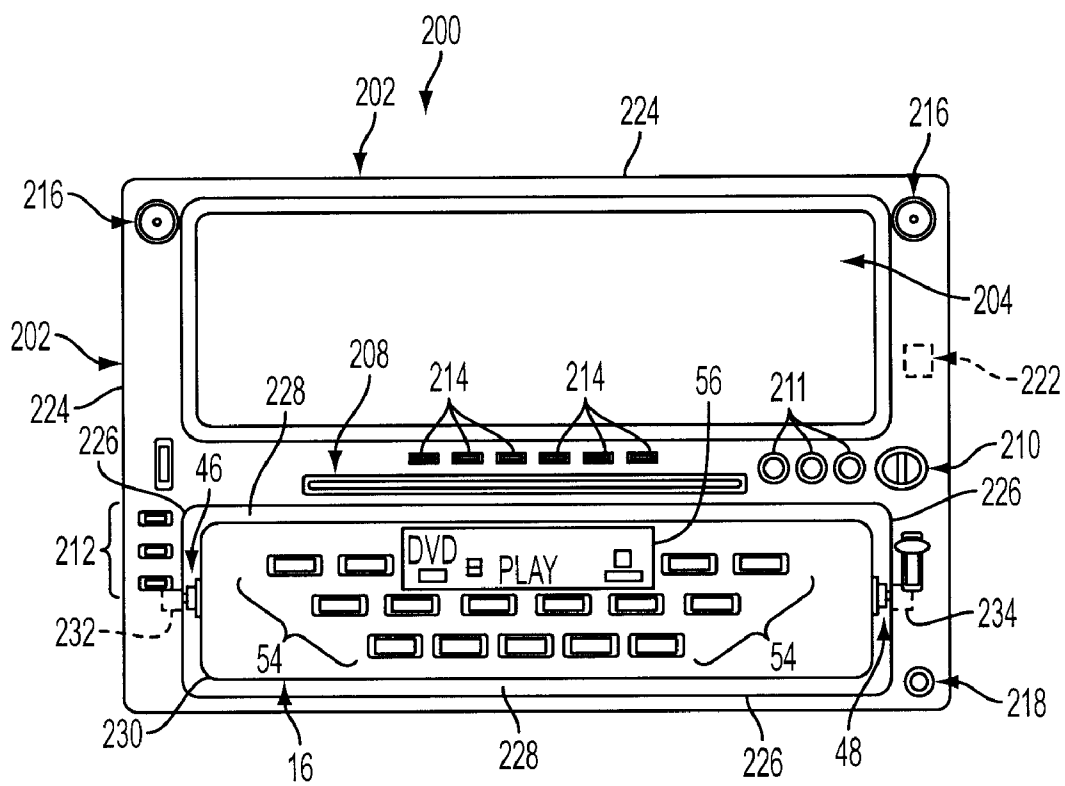

FIG. 18

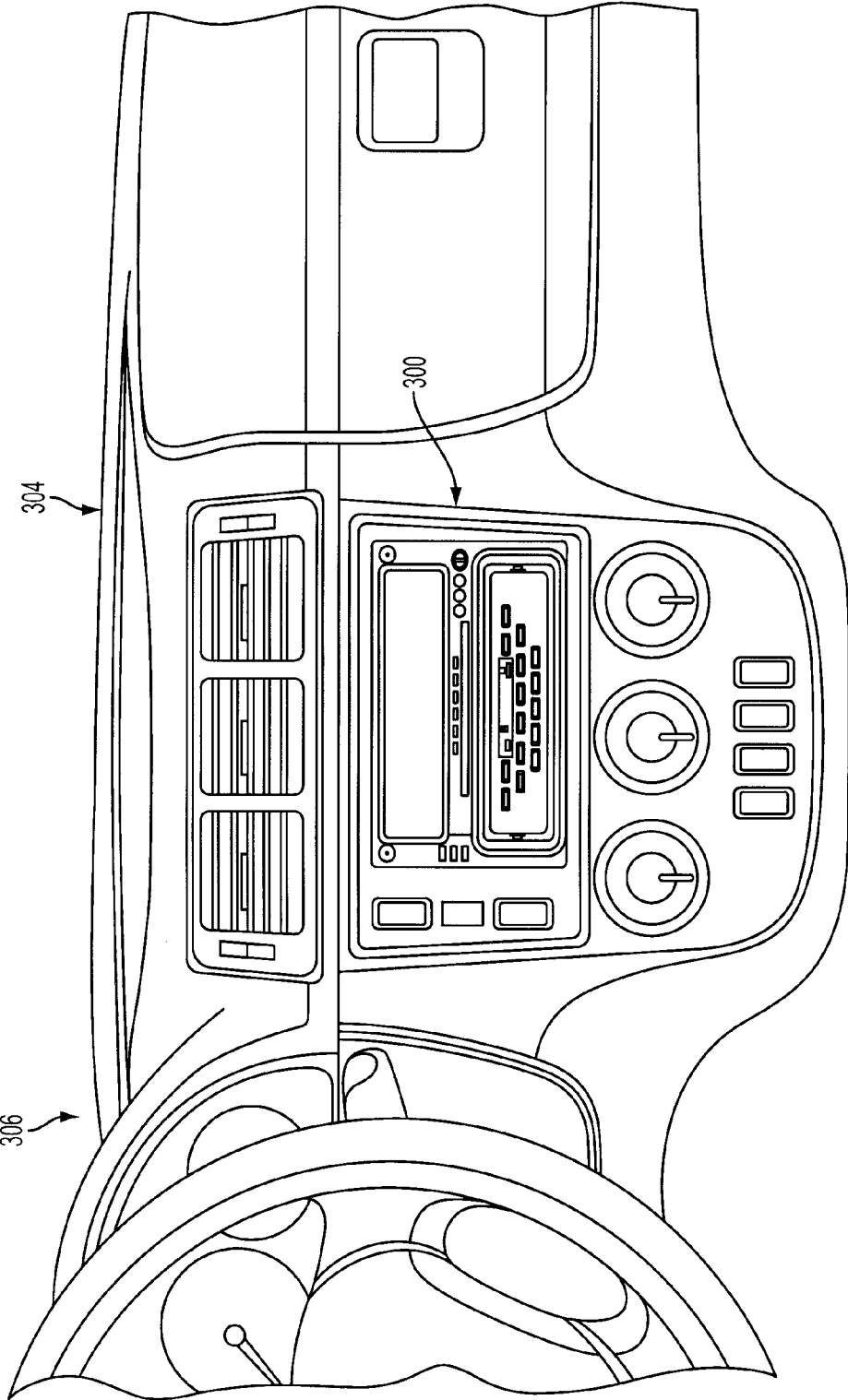

FIG. 19

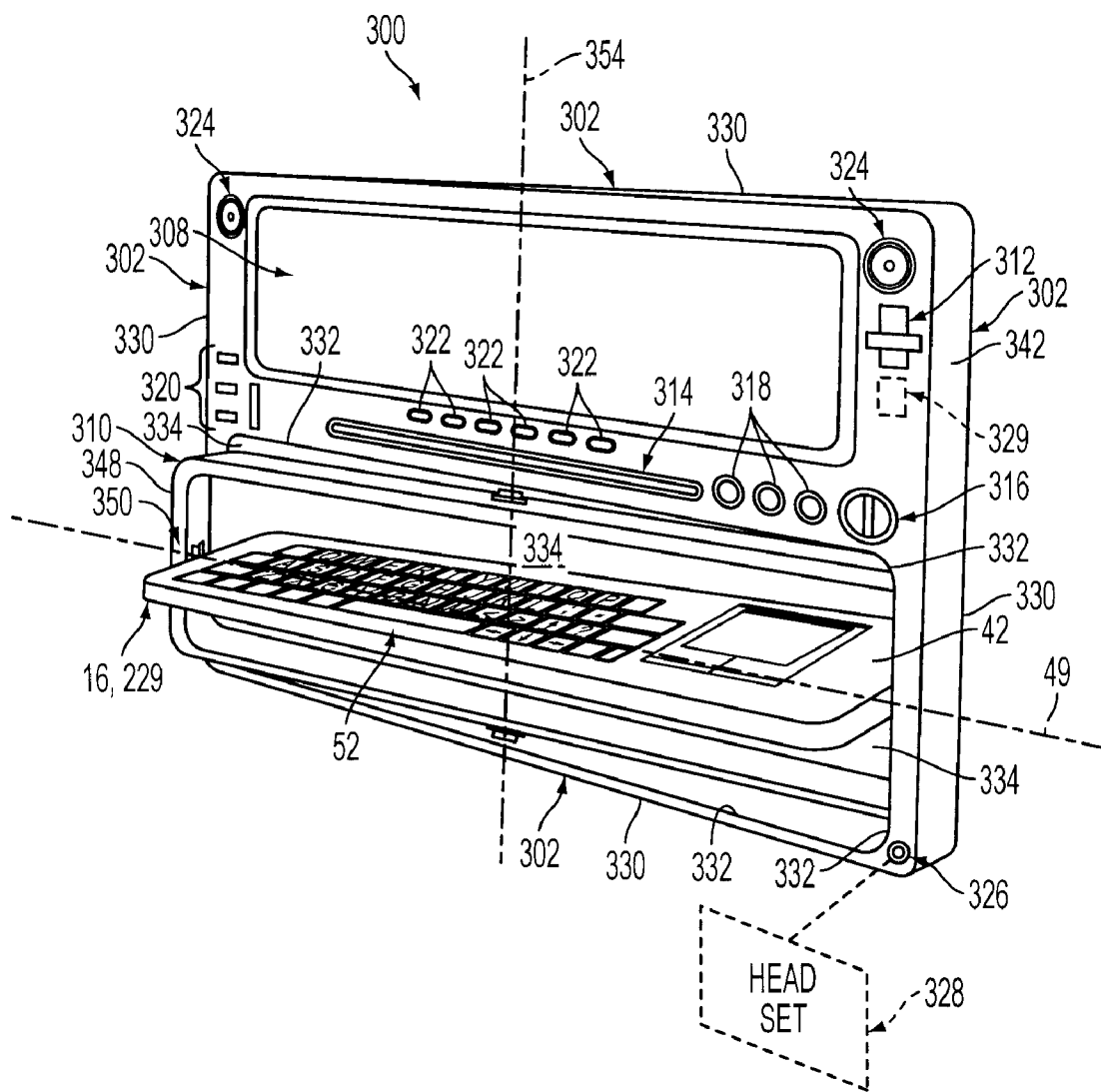

FIG. 20

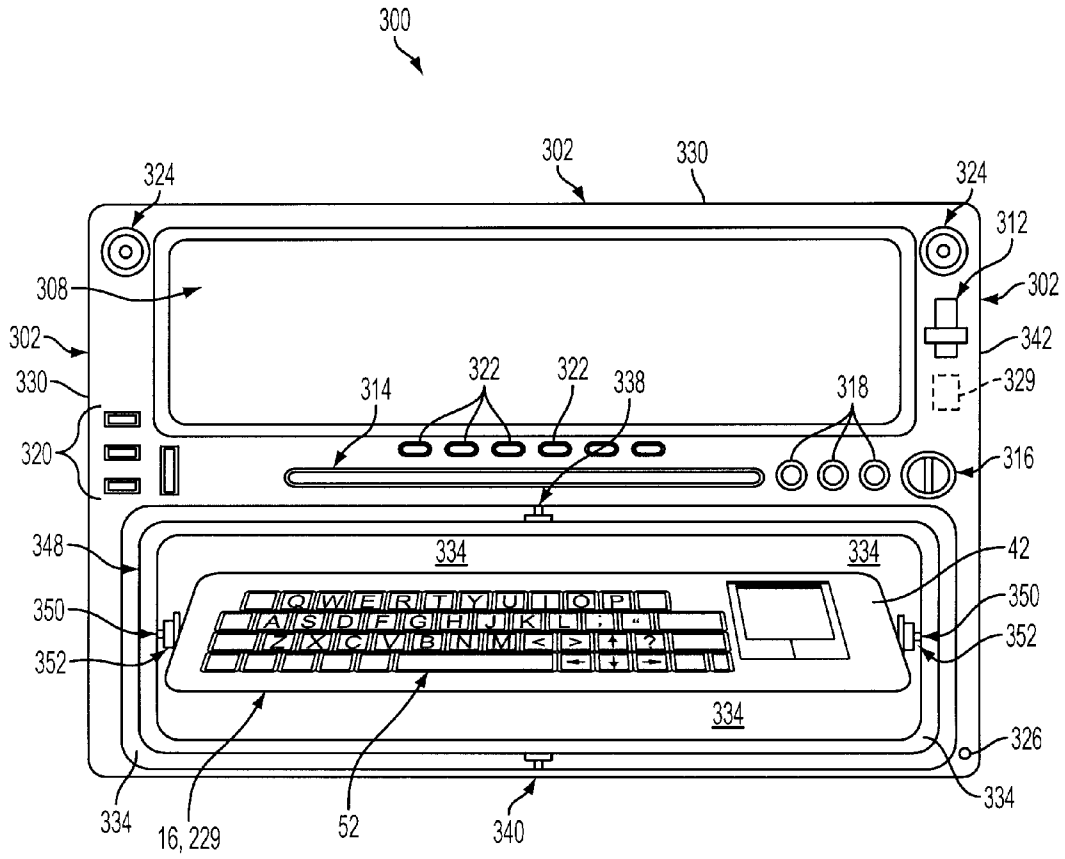

FIG. 21

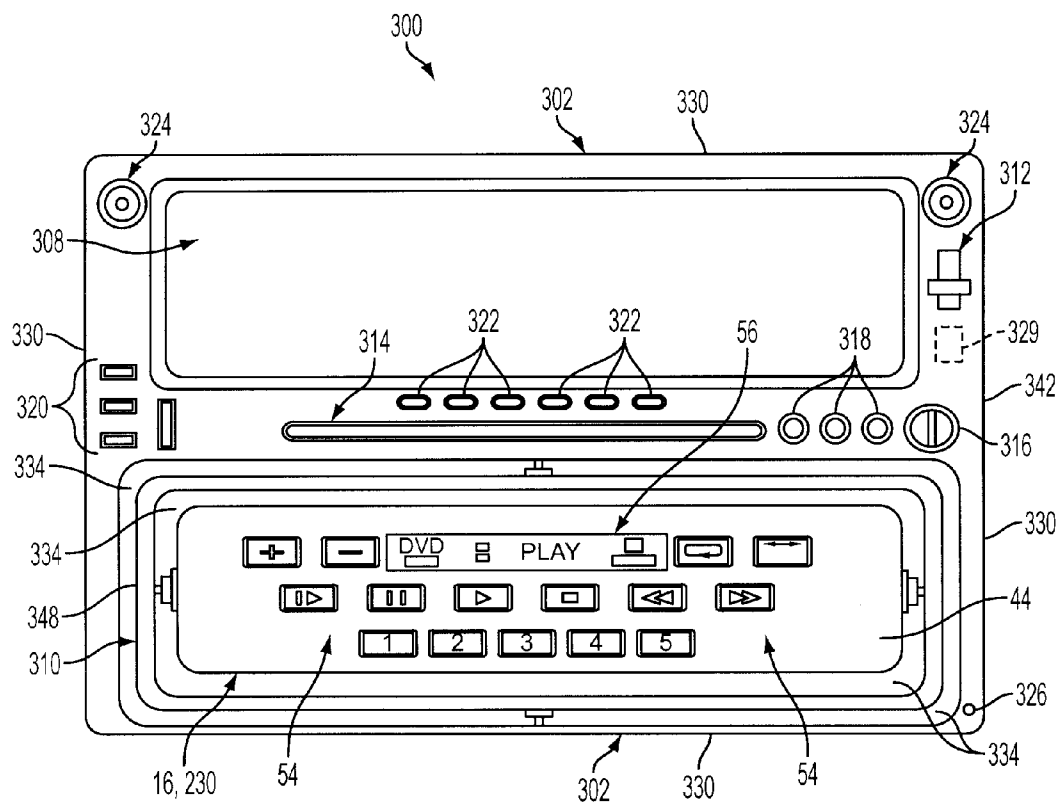

FIG. 22

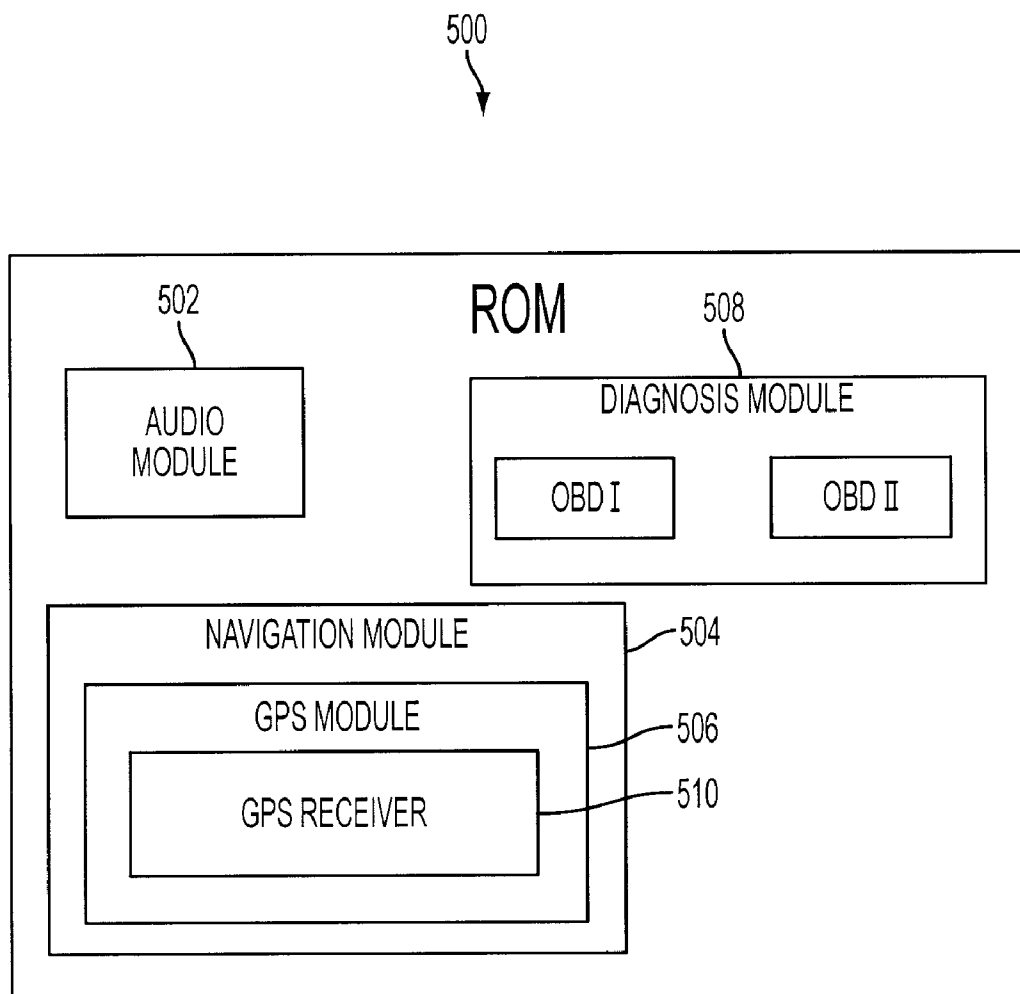

FIG. 23

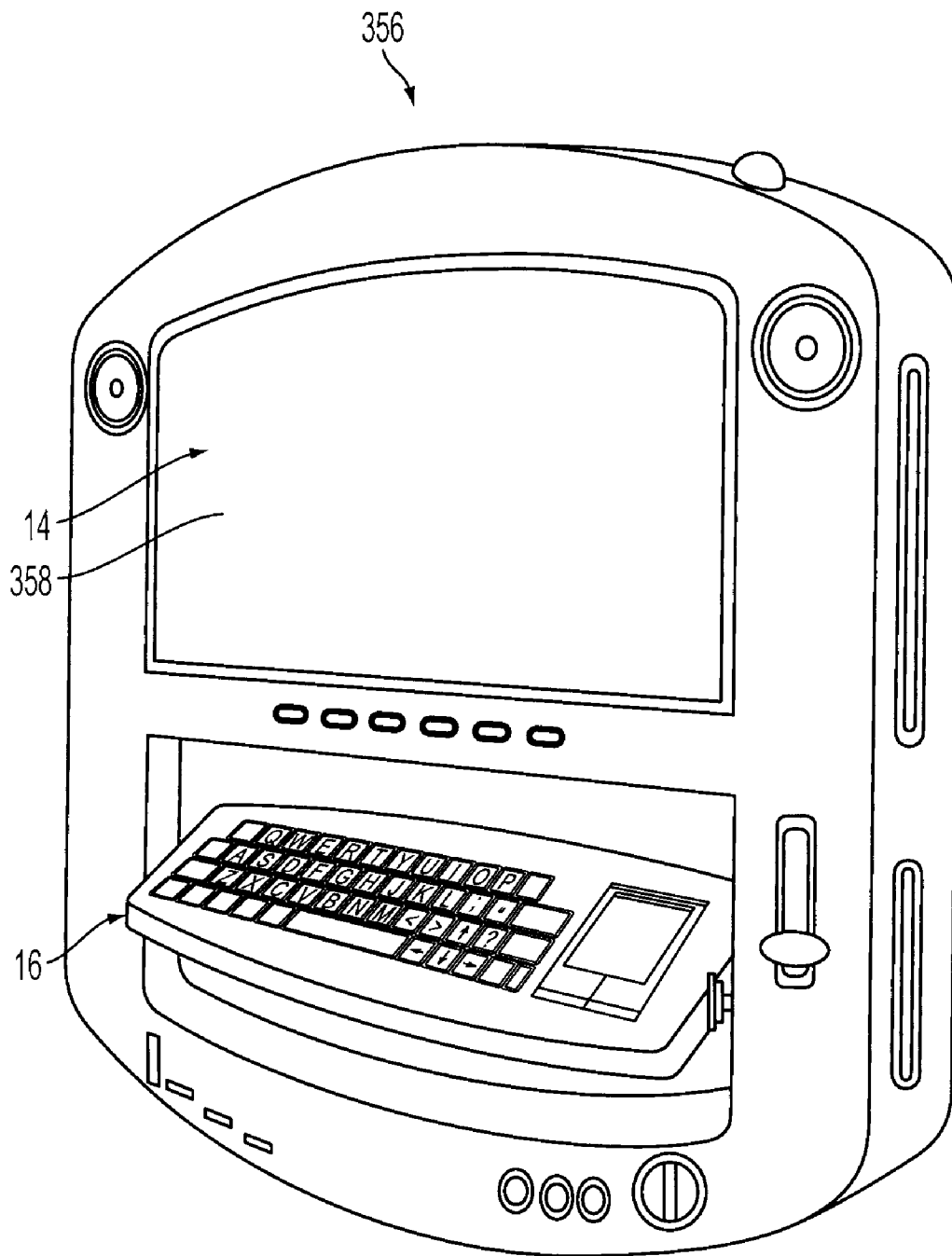

FIG. 24

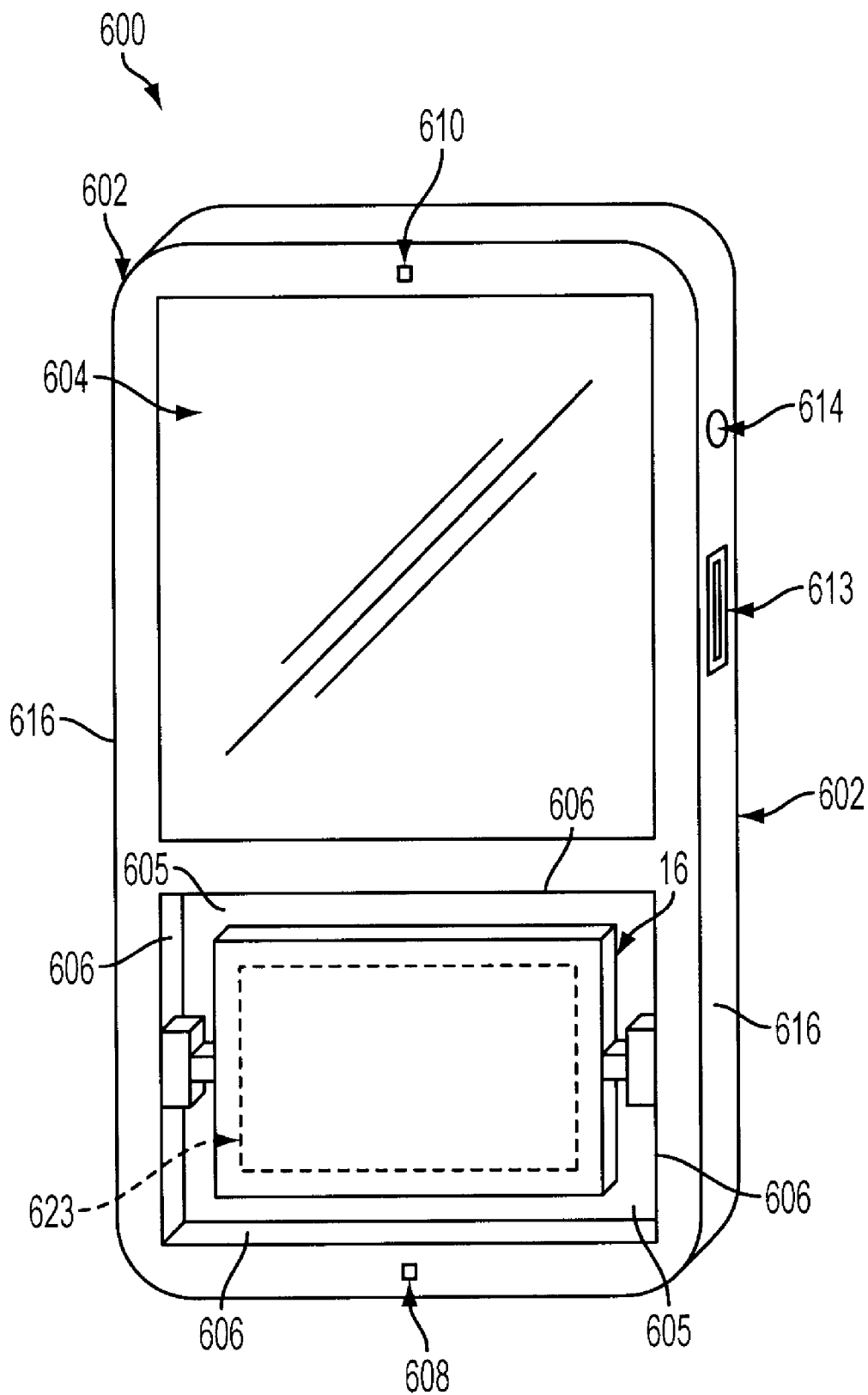

FIG. 25

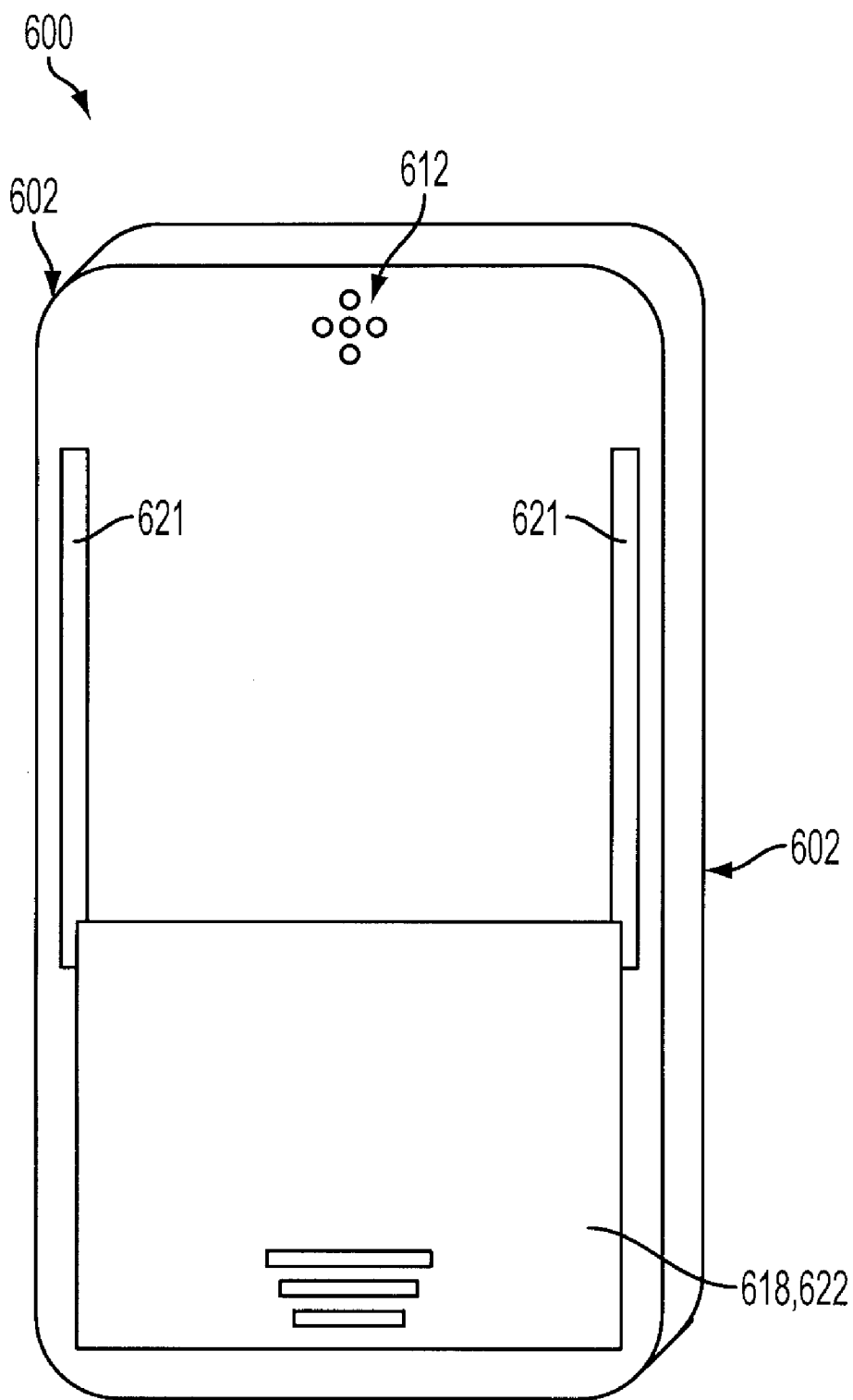

FIG. 26

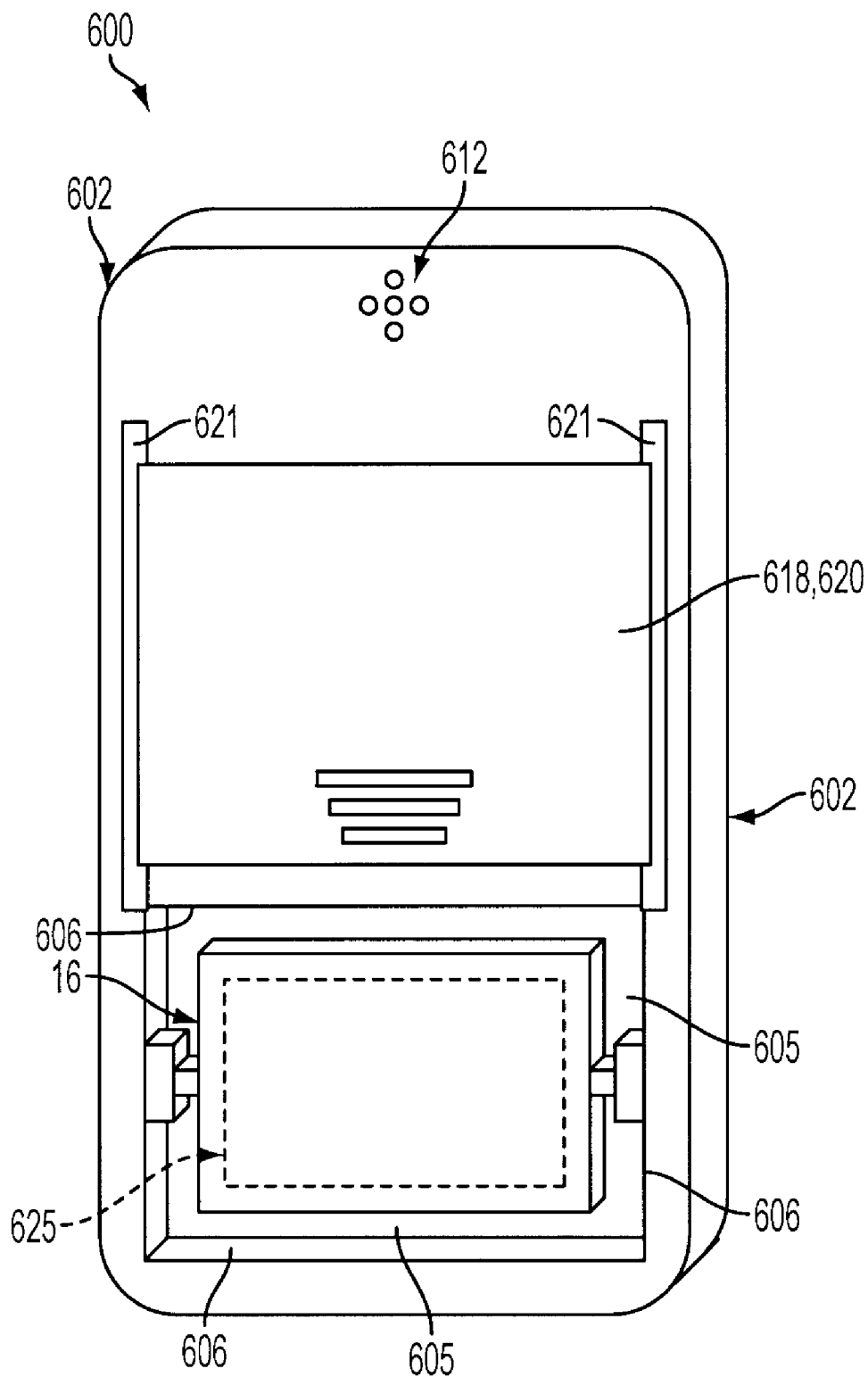

FIG. 27

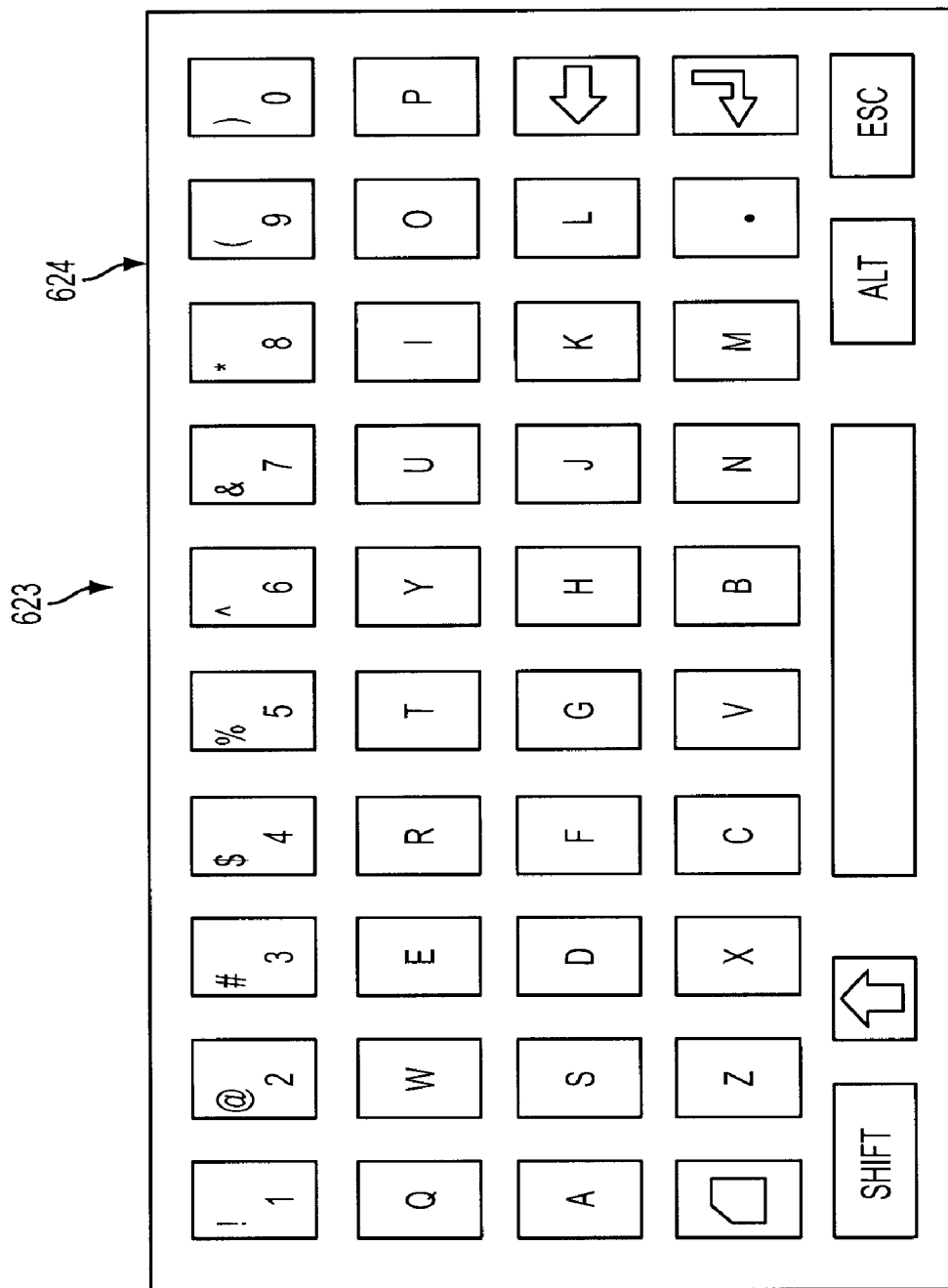

FIG. 28

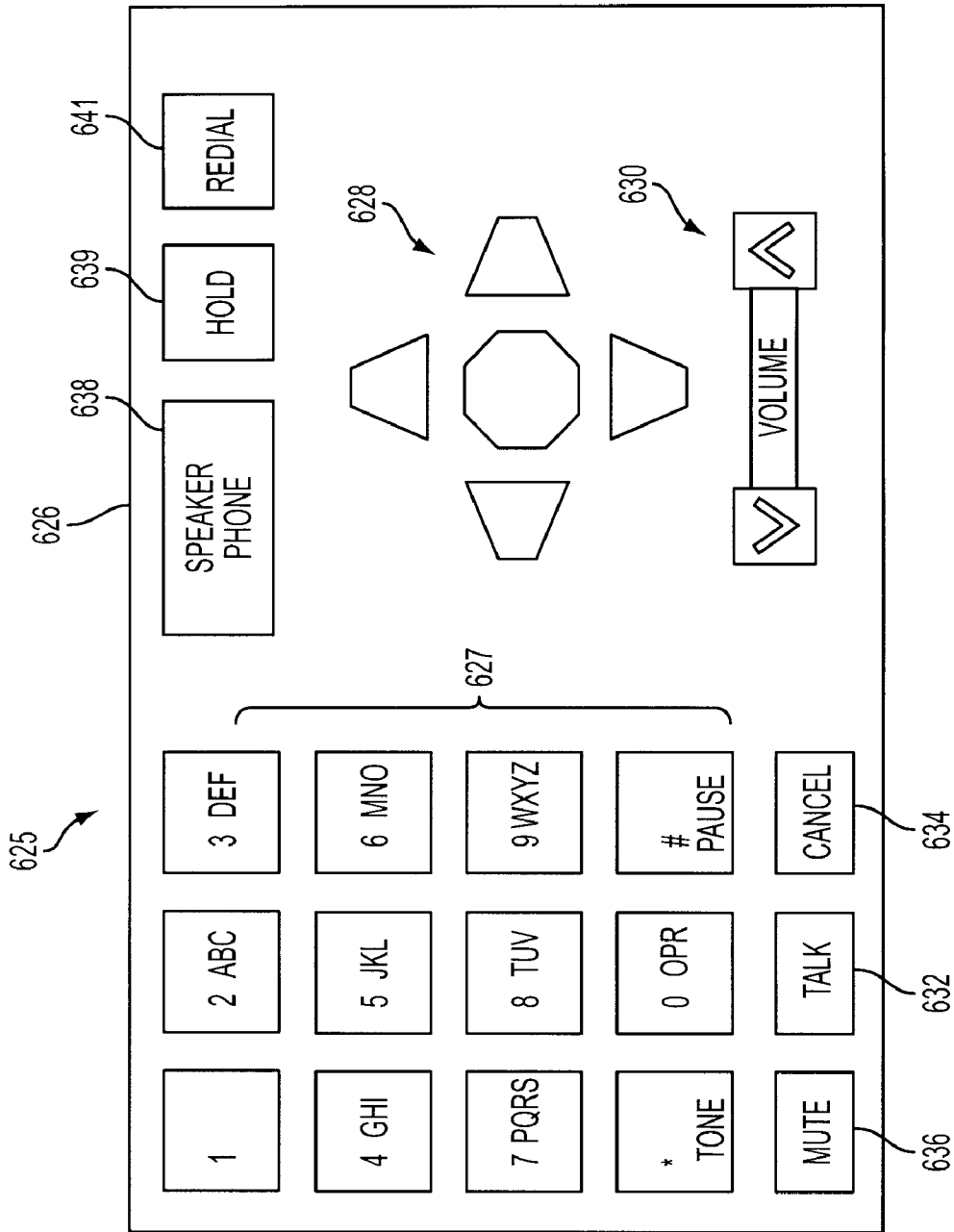

FIG. 29

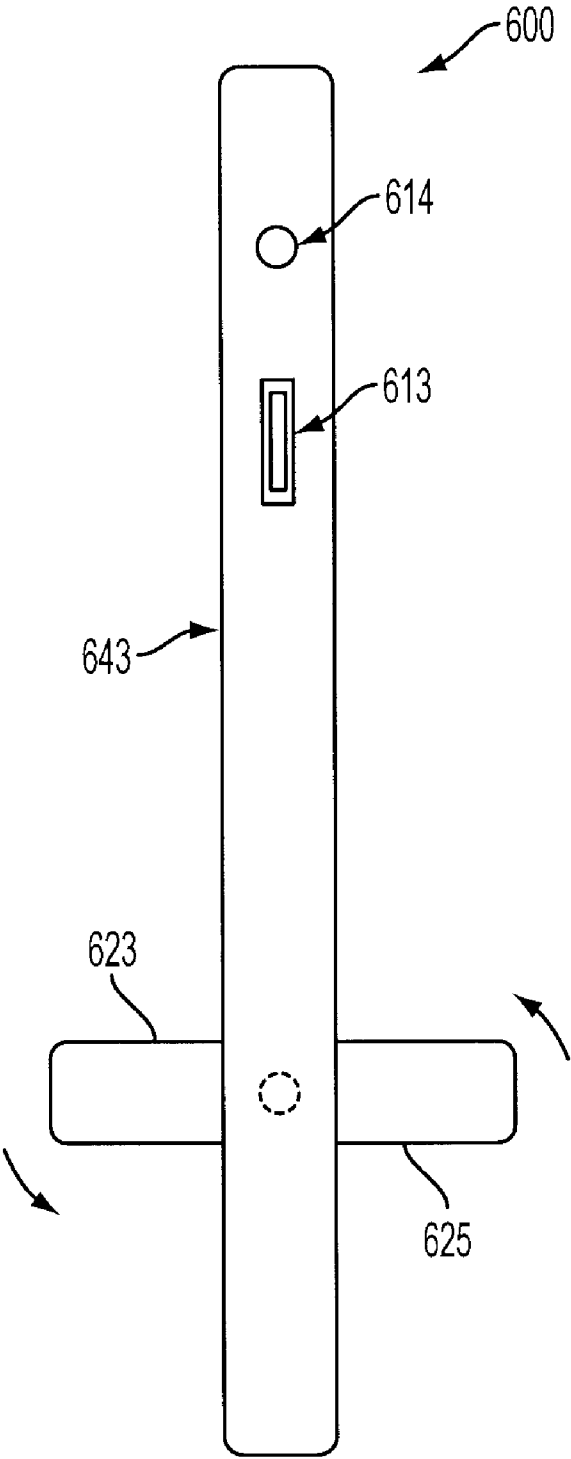

FIG. 30

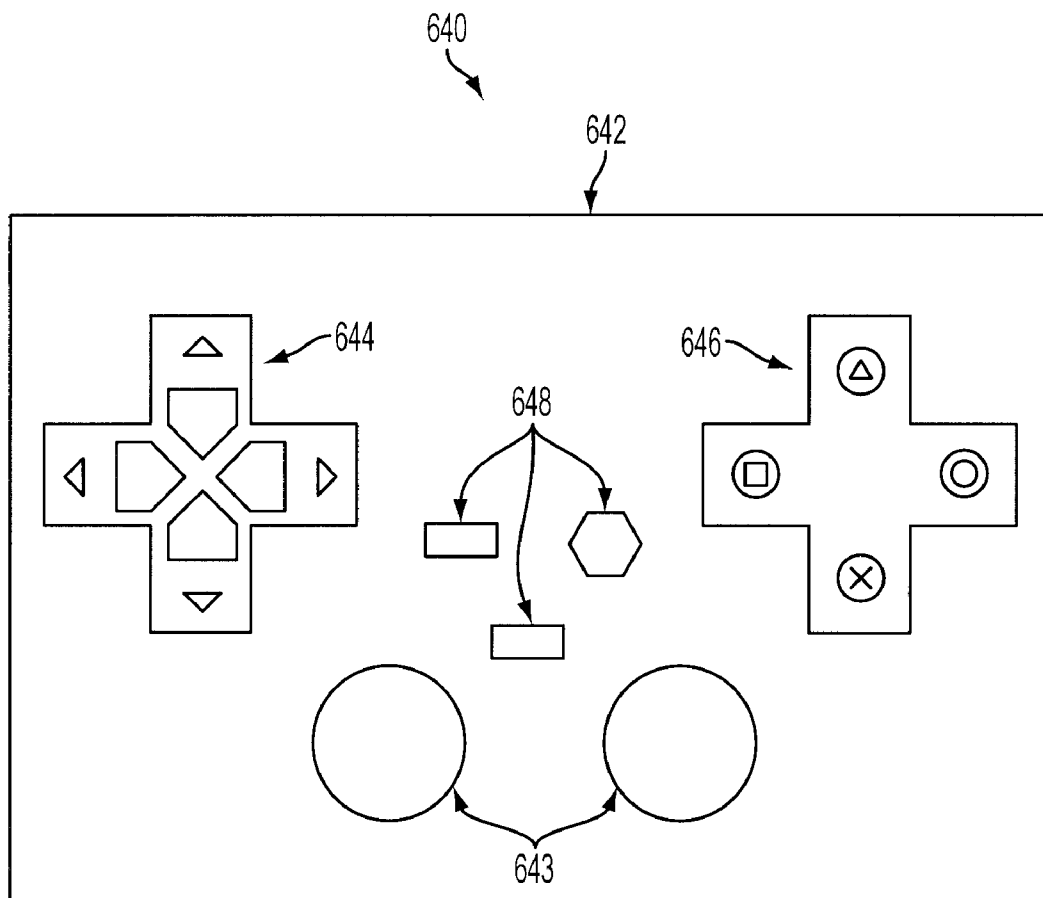

FIG. 31

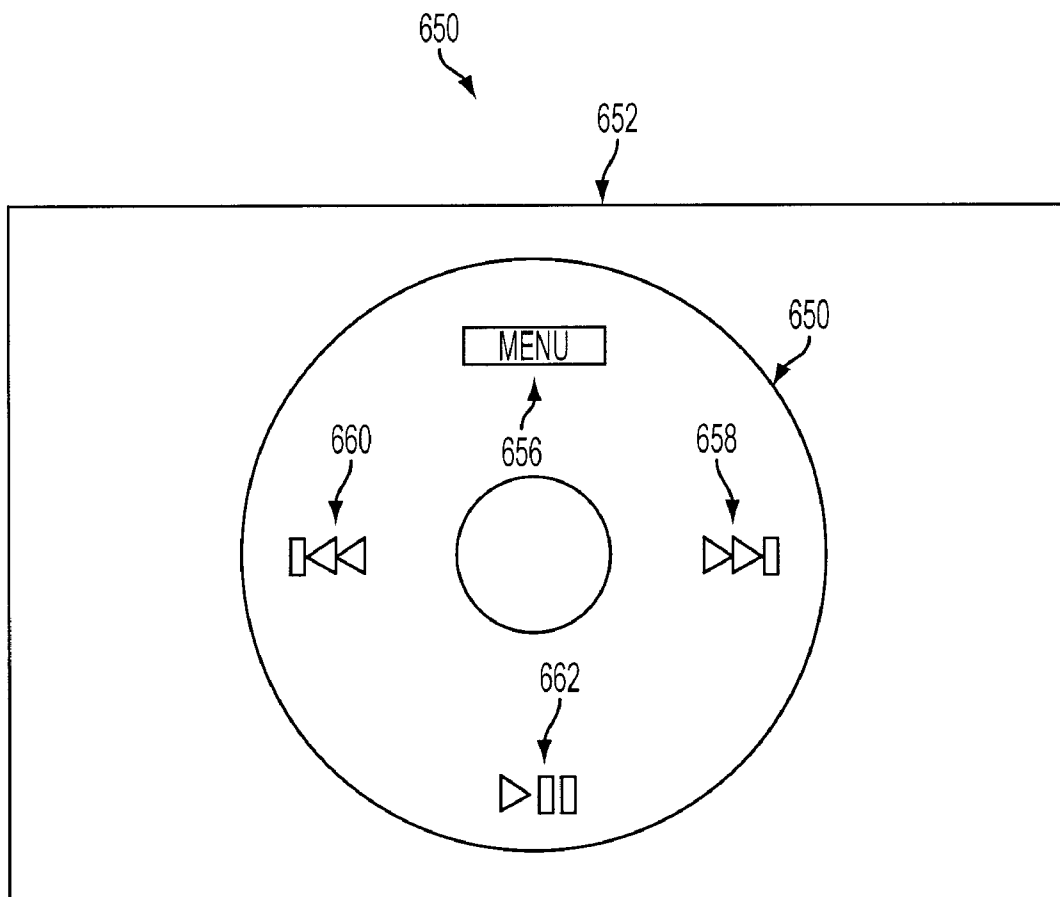

FIG. 32

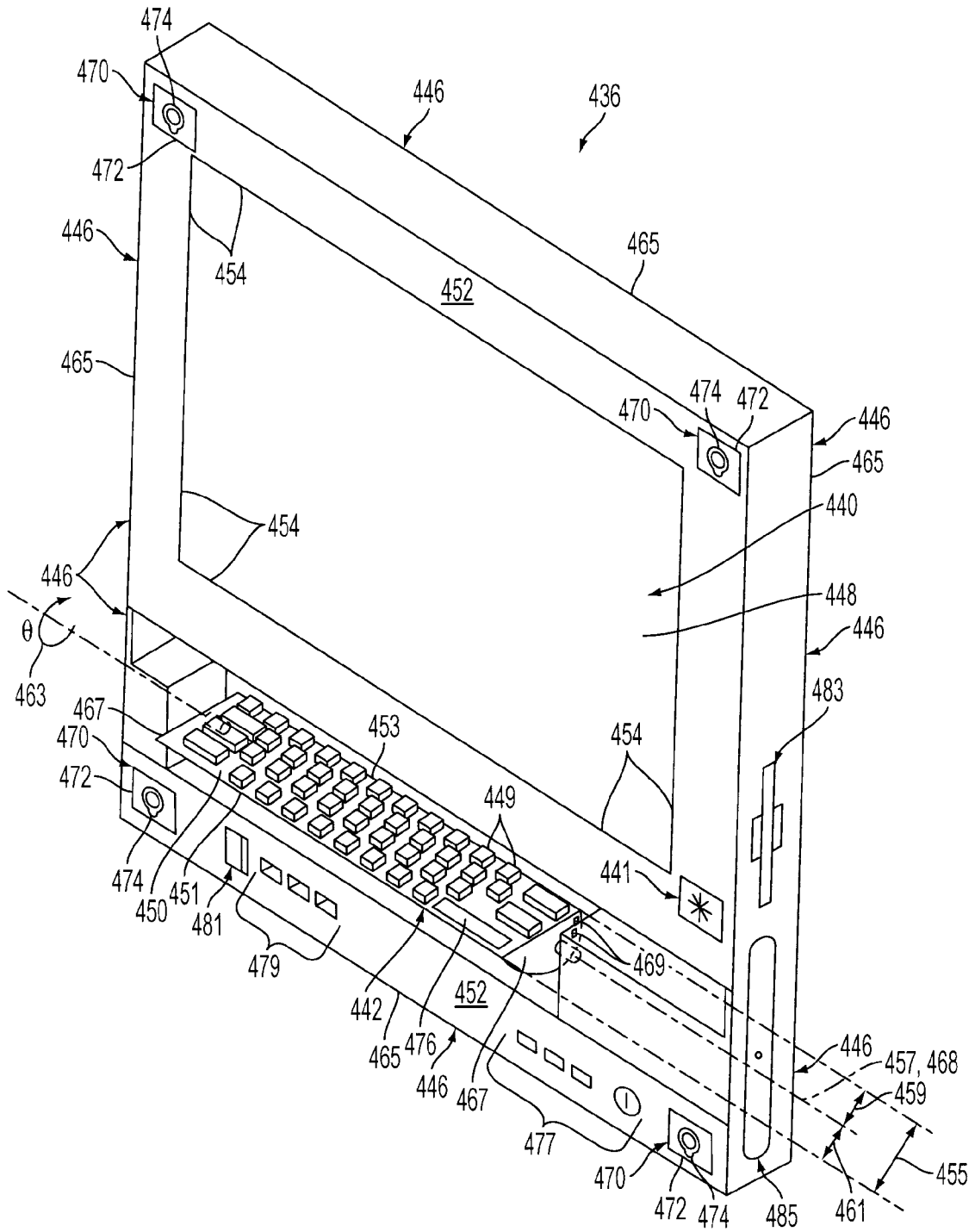

FIG. 33

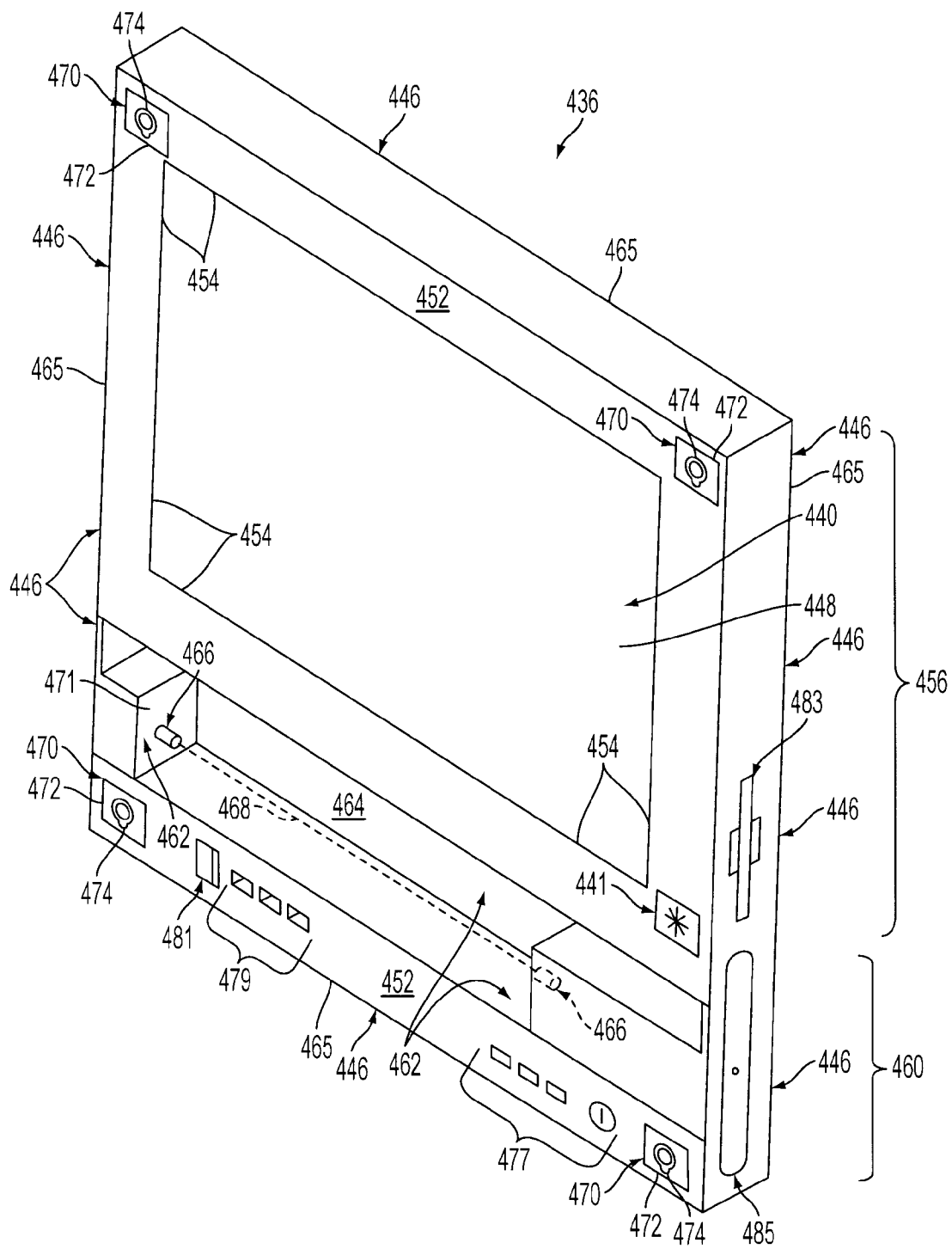

FIG. 34

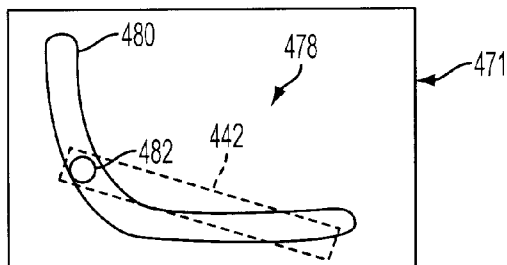

FIG. 35

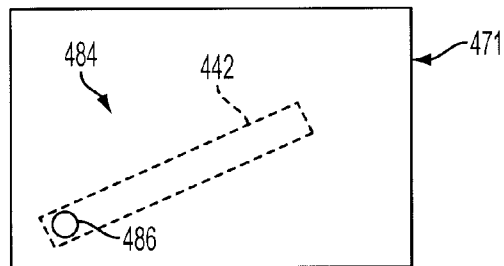

FIG. 36

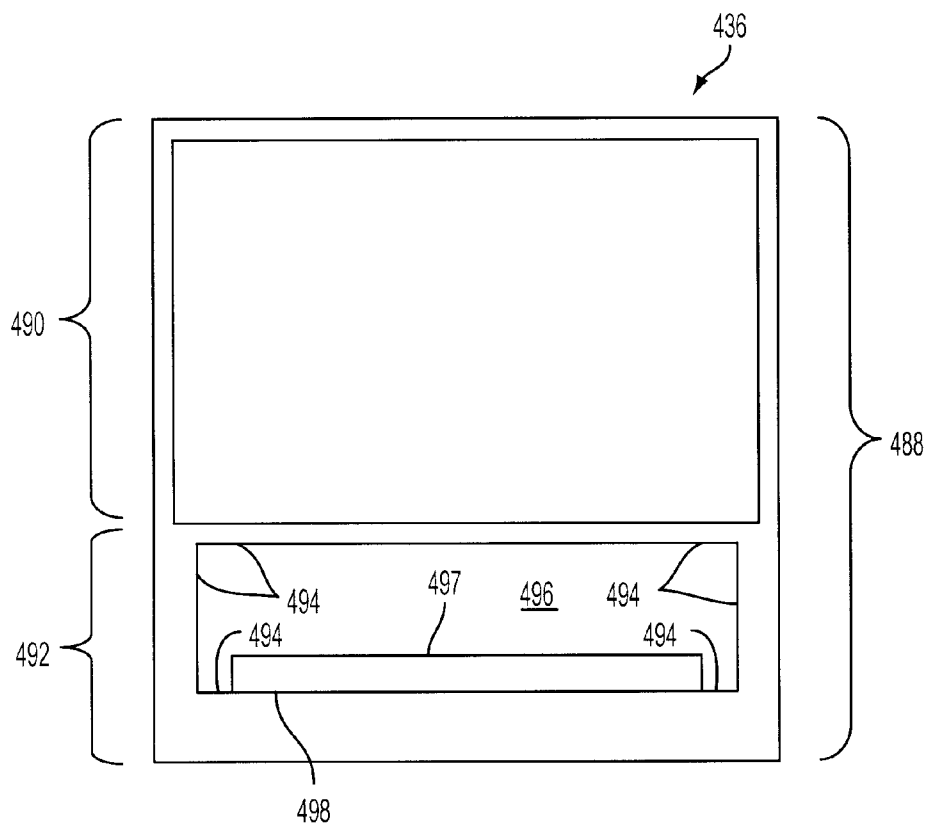

FIG. 37

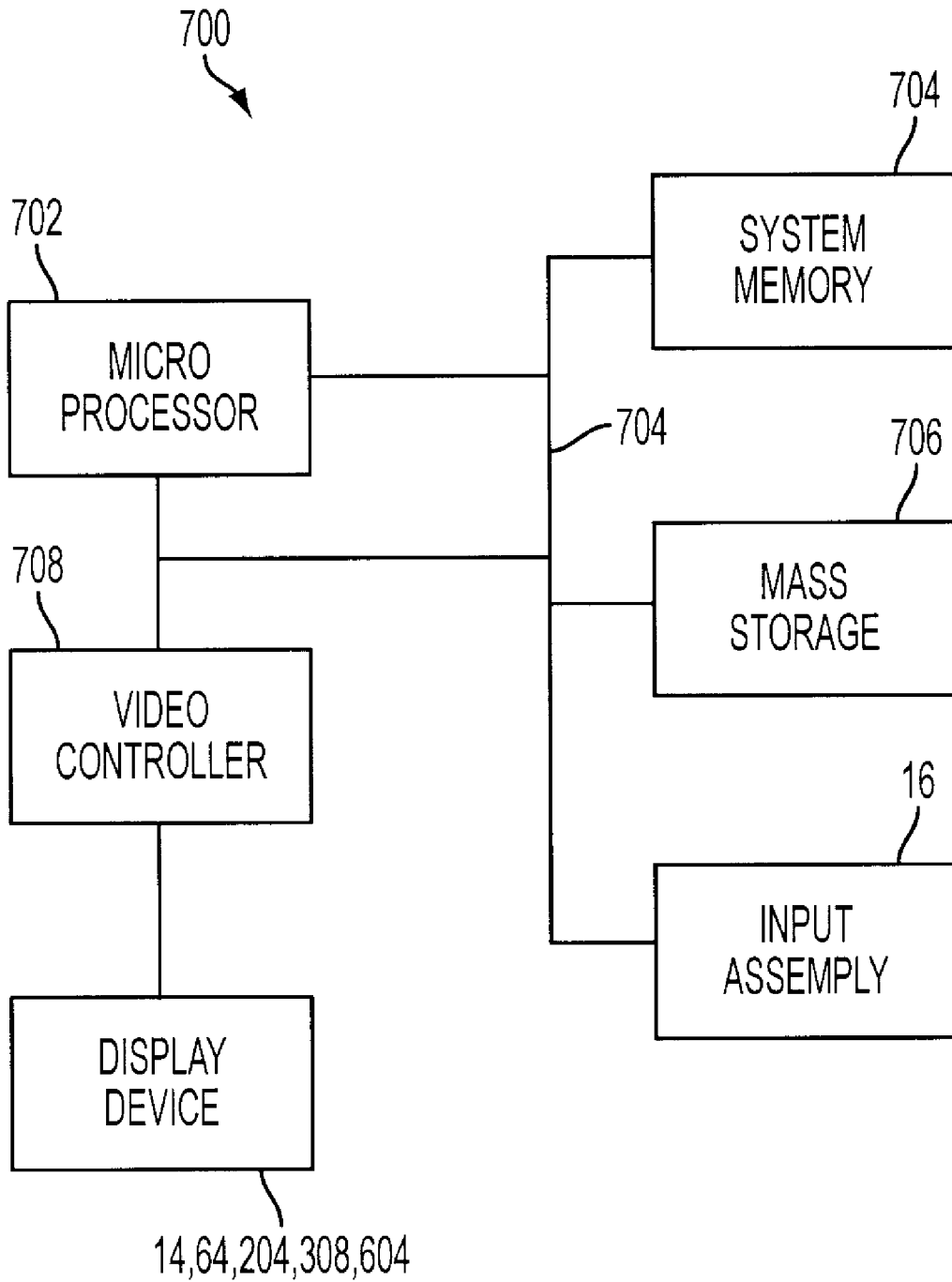

FIG. 38

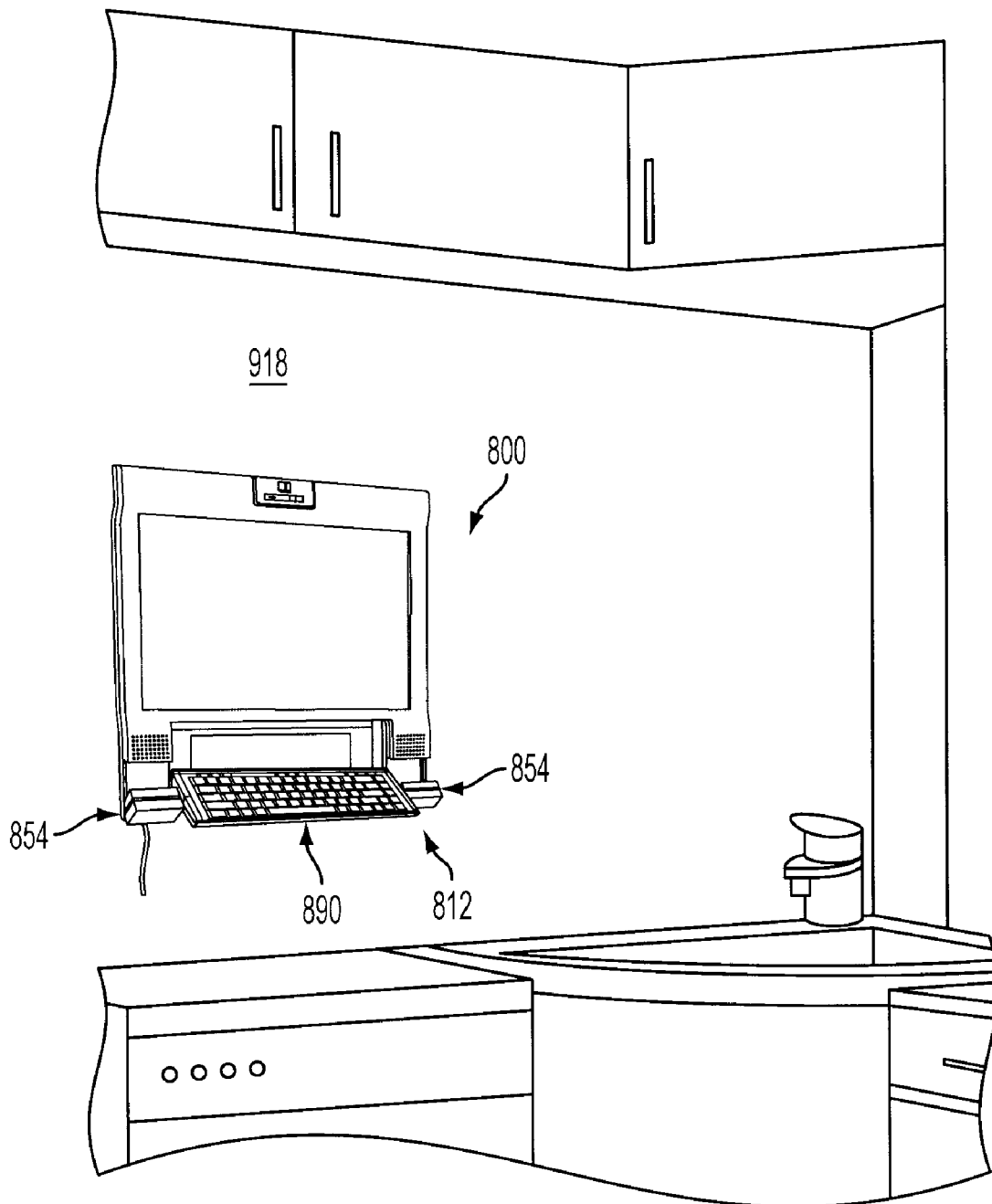

FIG. 39

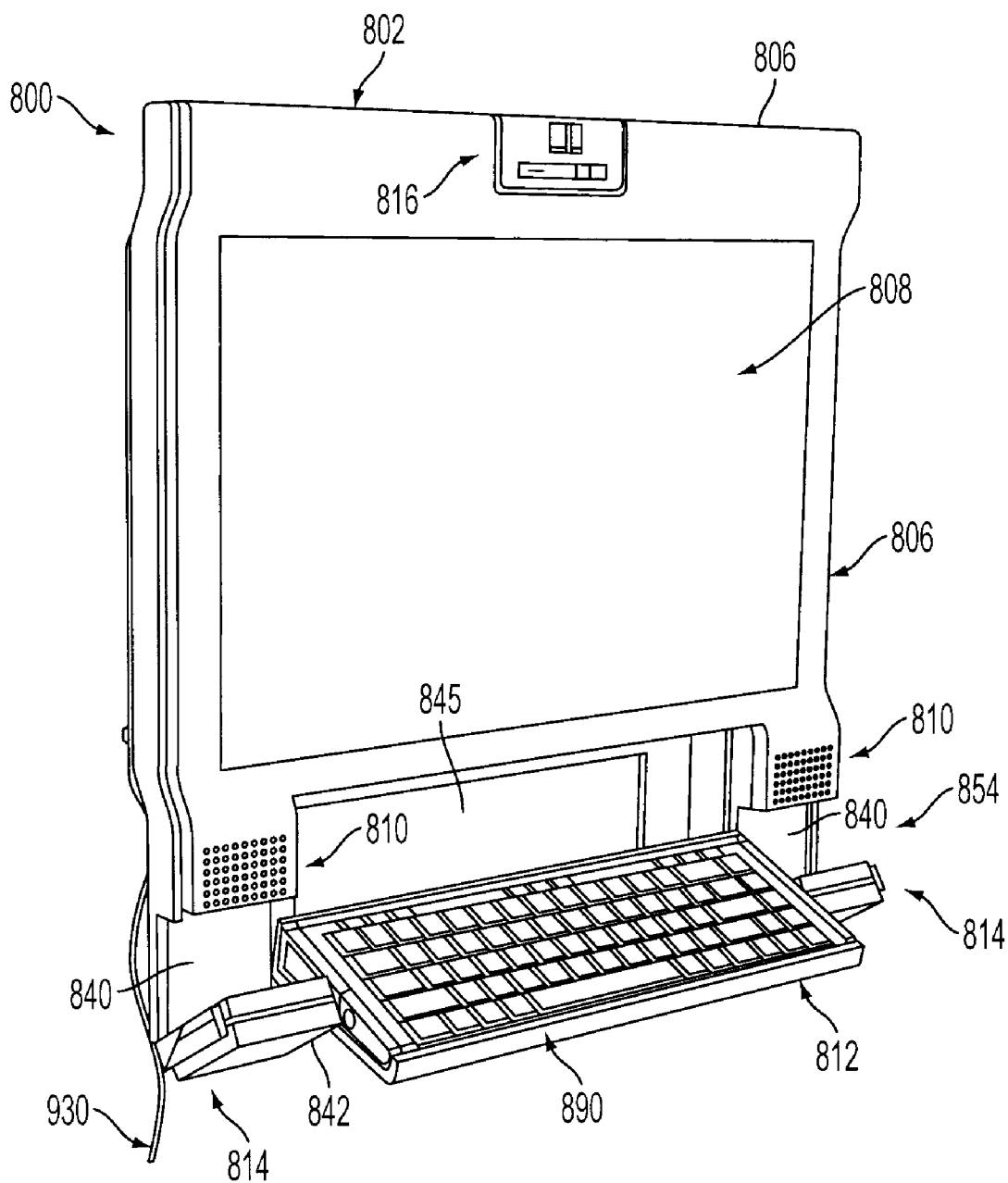

FIG. 40

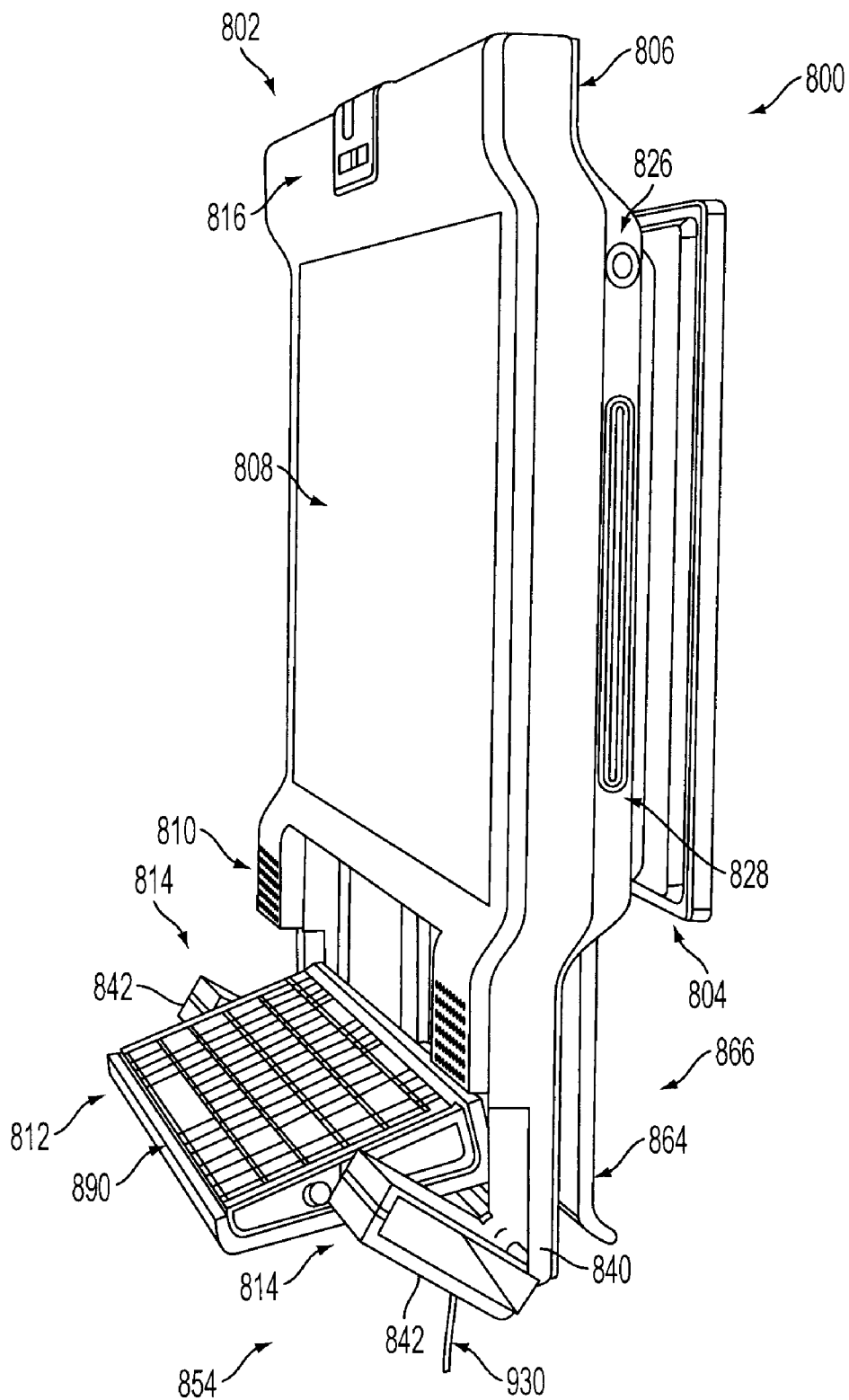

FIG. 41

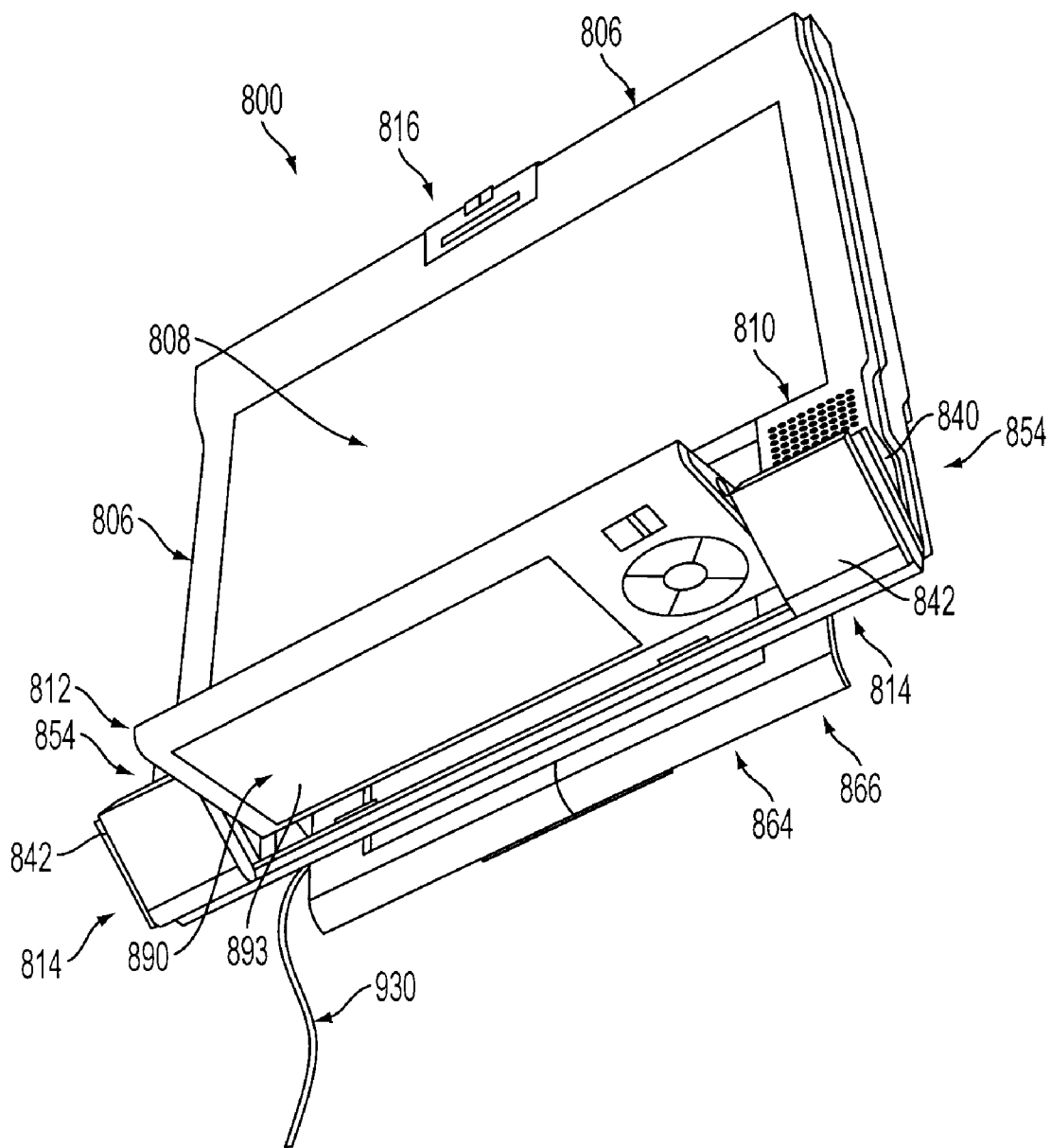

FIG. 42

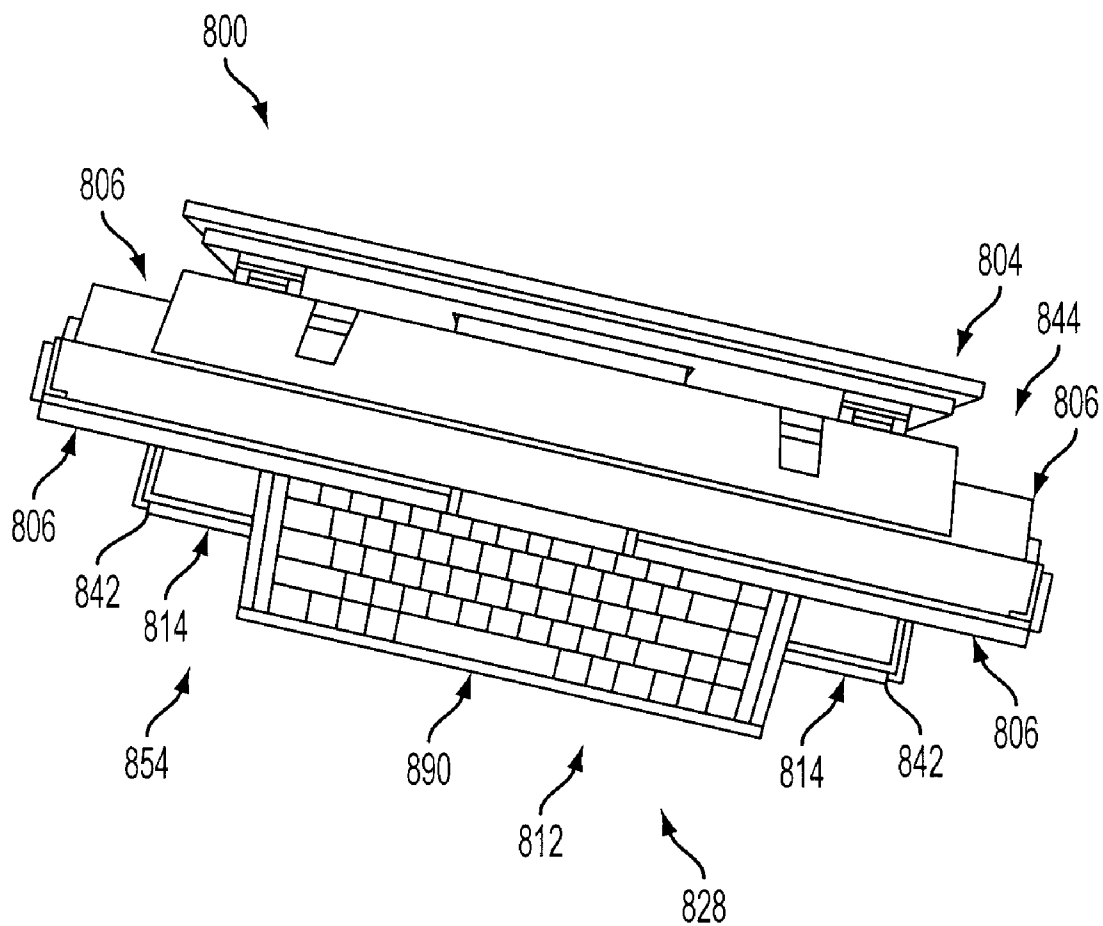

FIG. 43

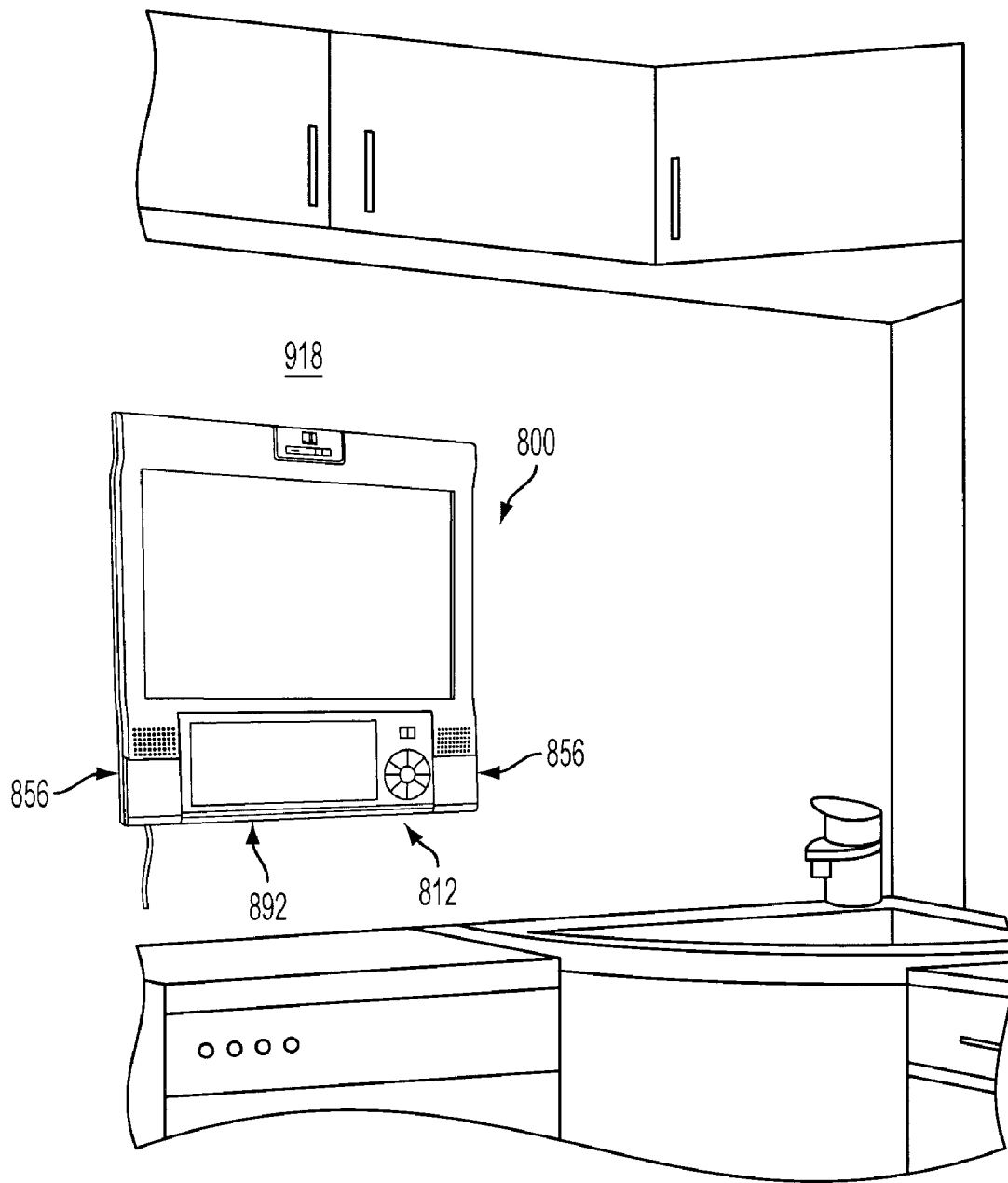

FIG. 44

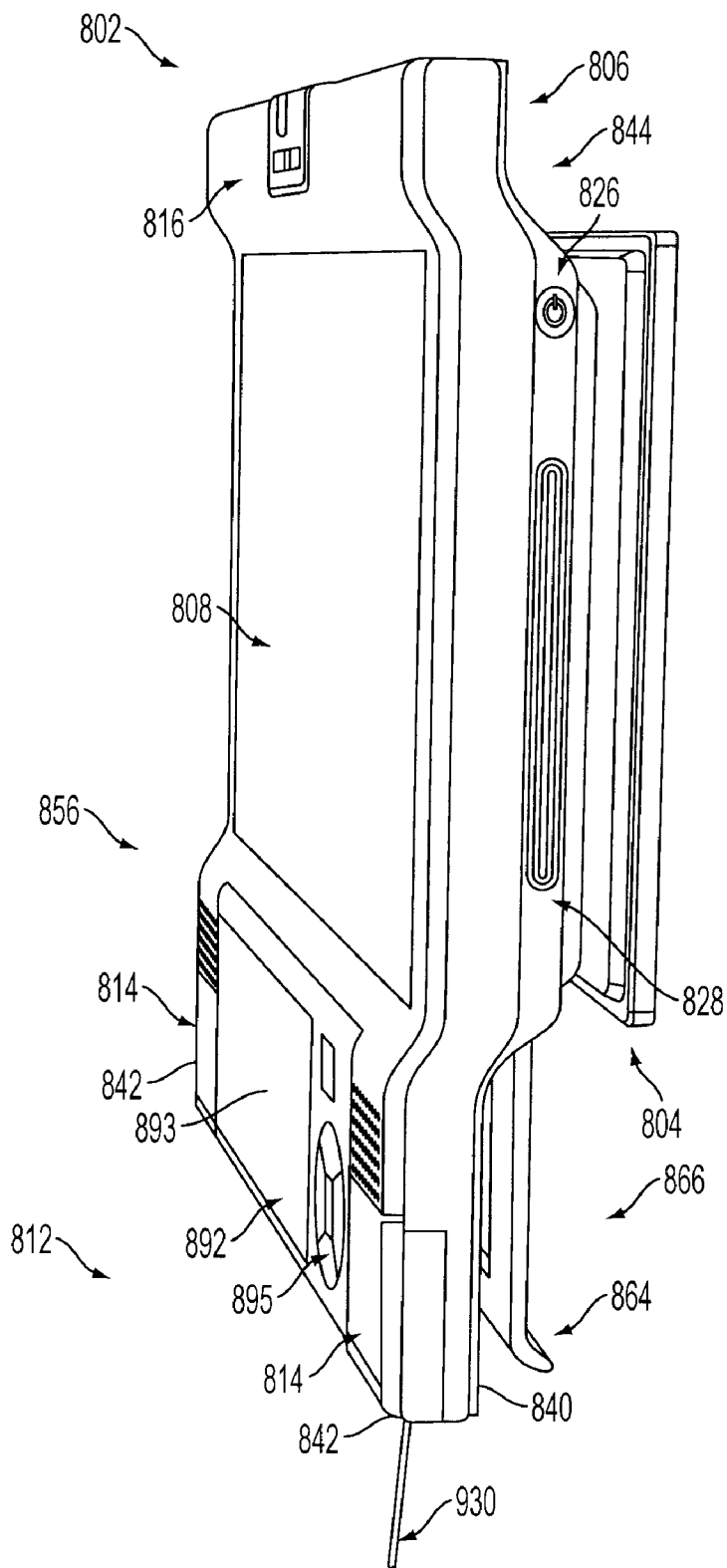

FIG. 45

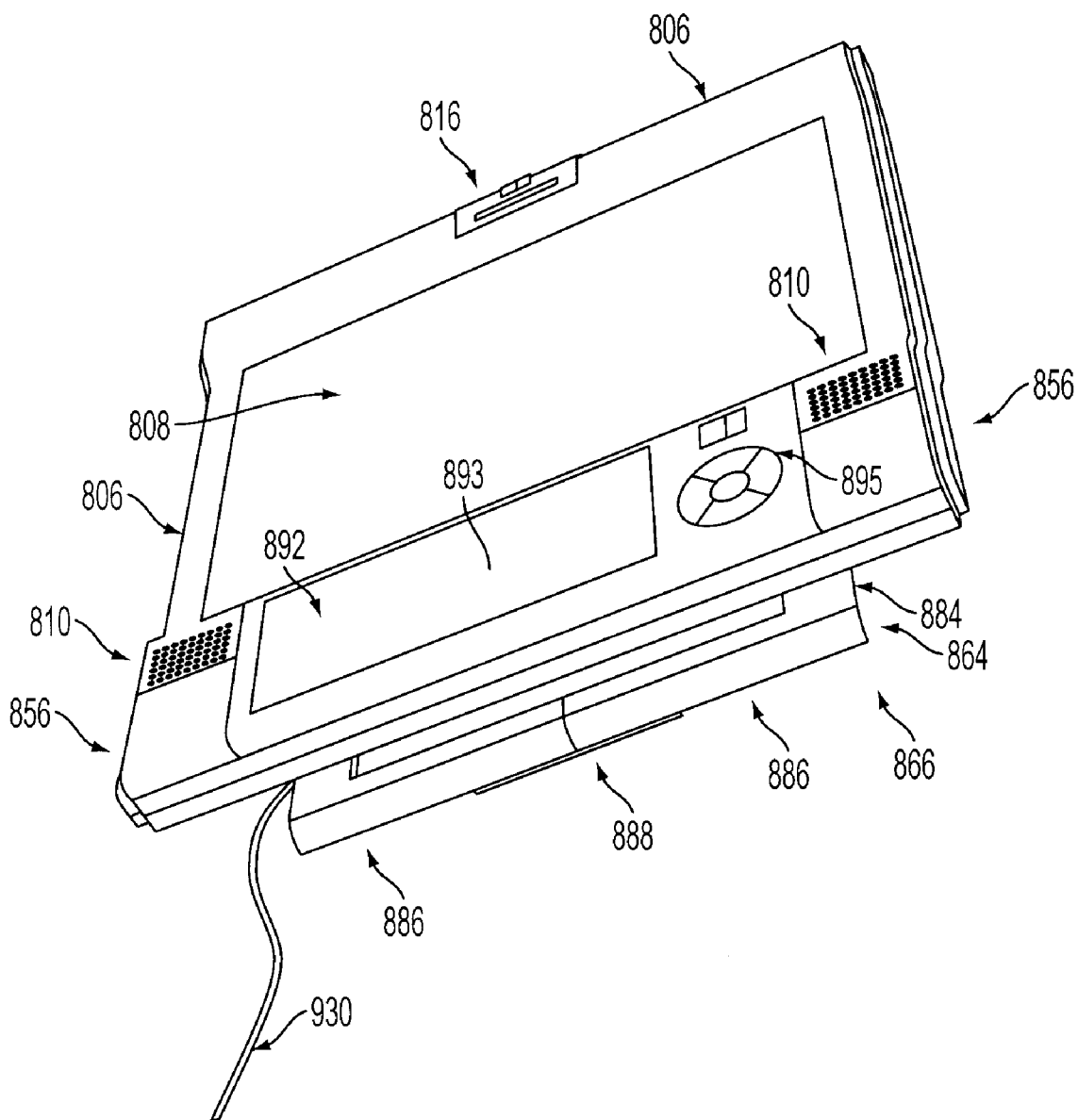

FIG. 46

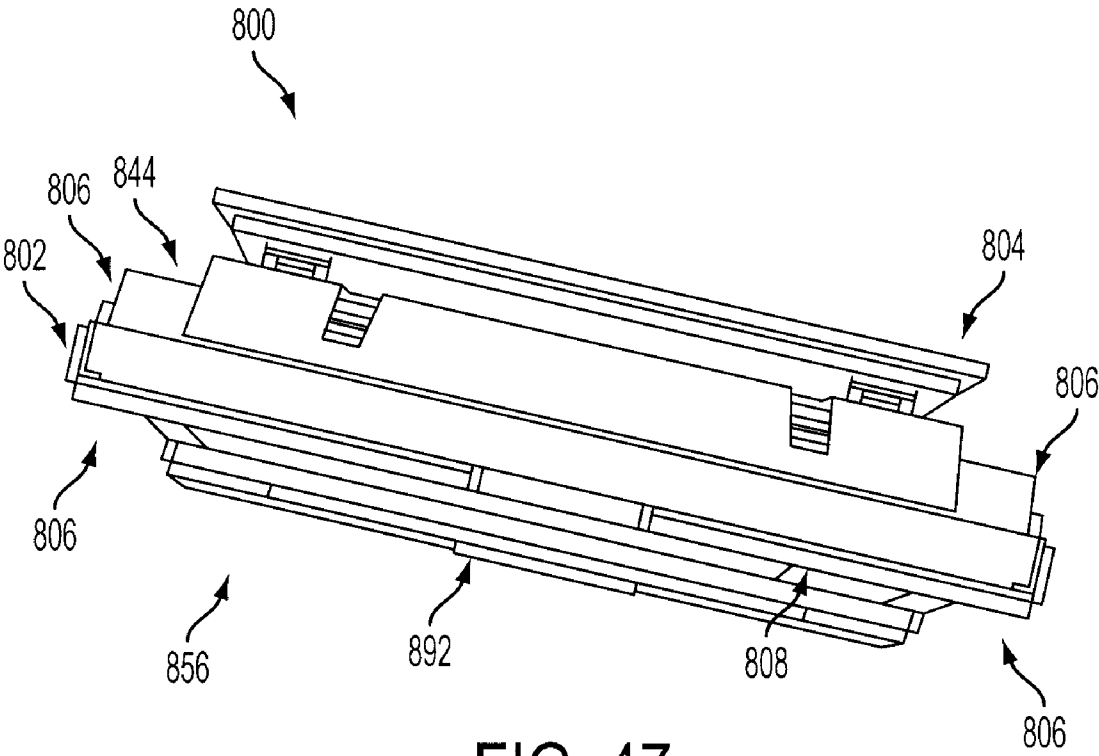

FIG. 47

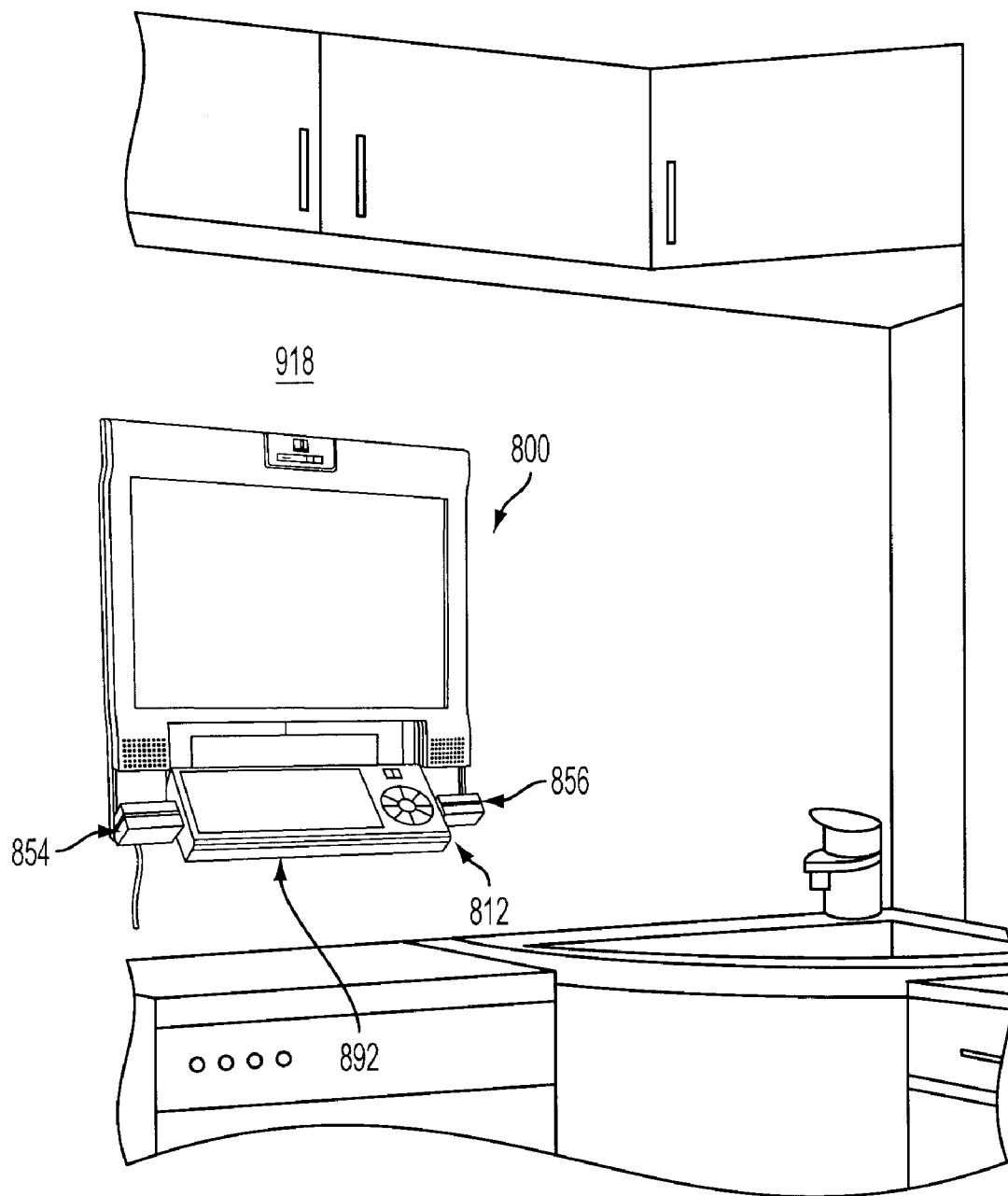

FIG. 48

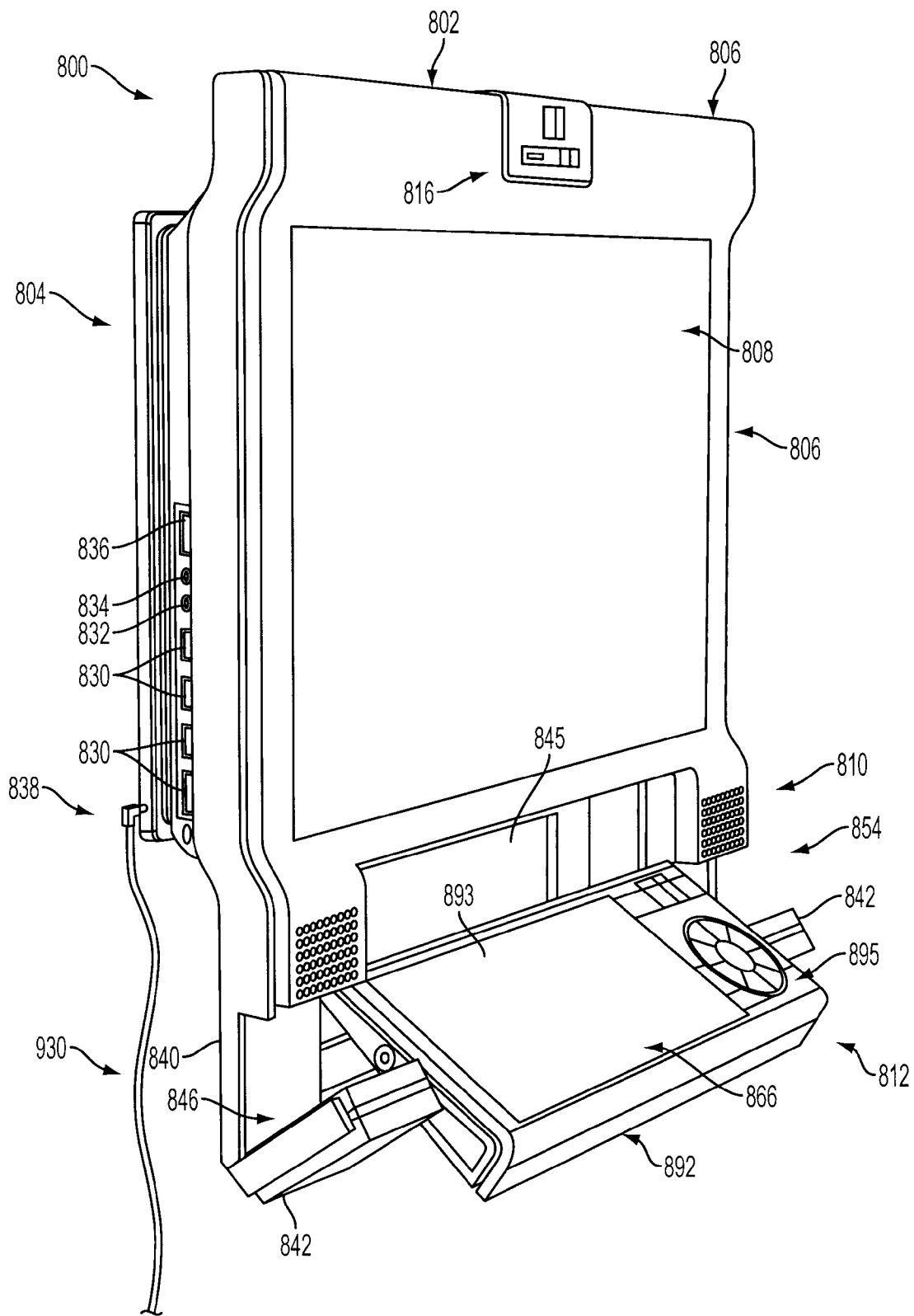

FIG. 49

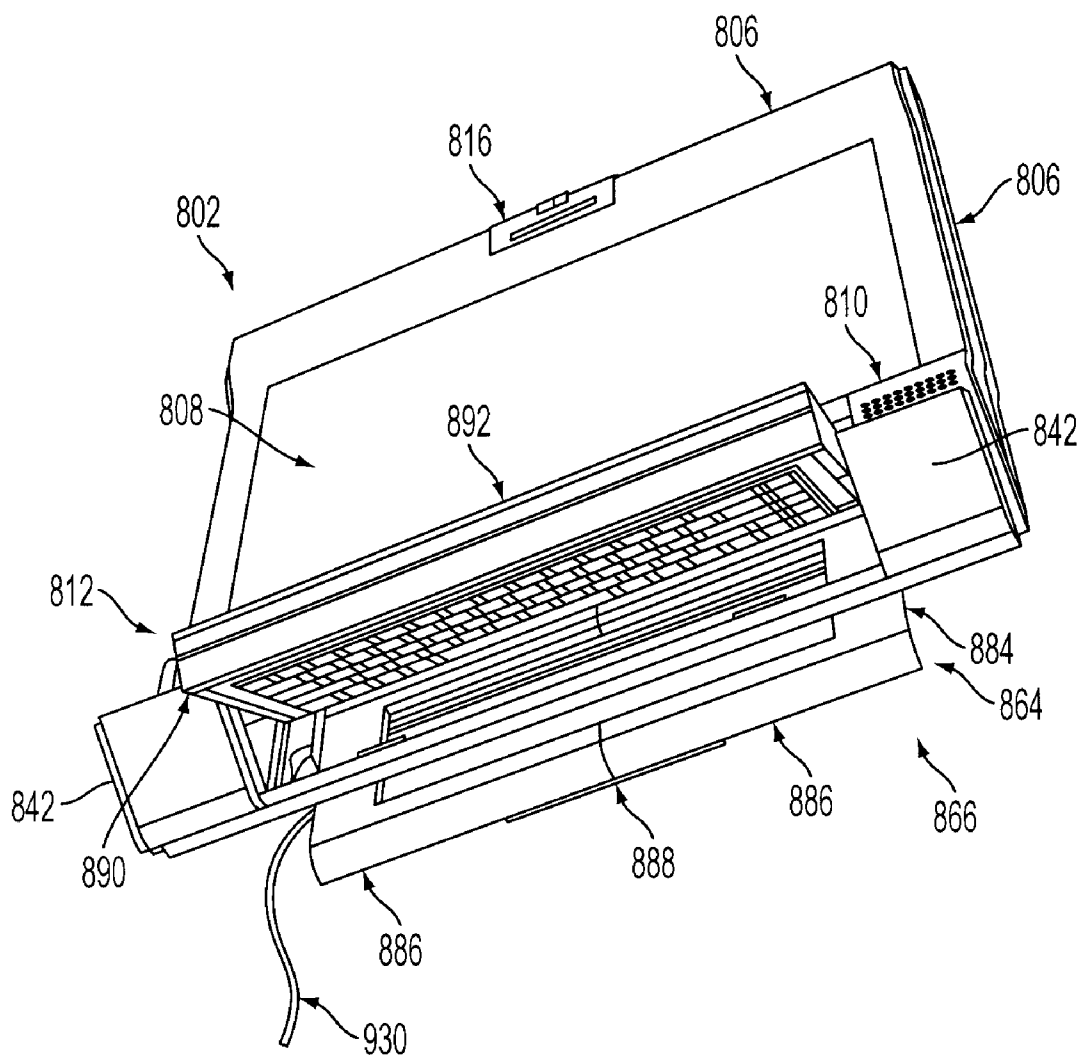

FIG. 51

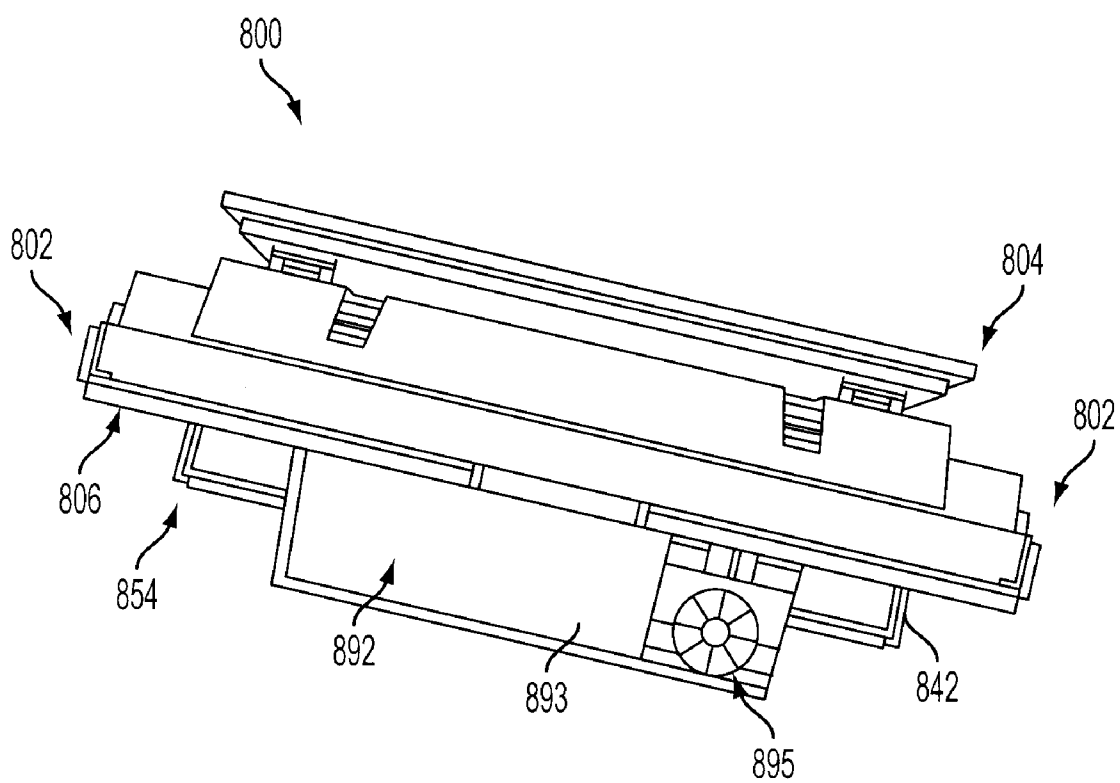

FIG. 52

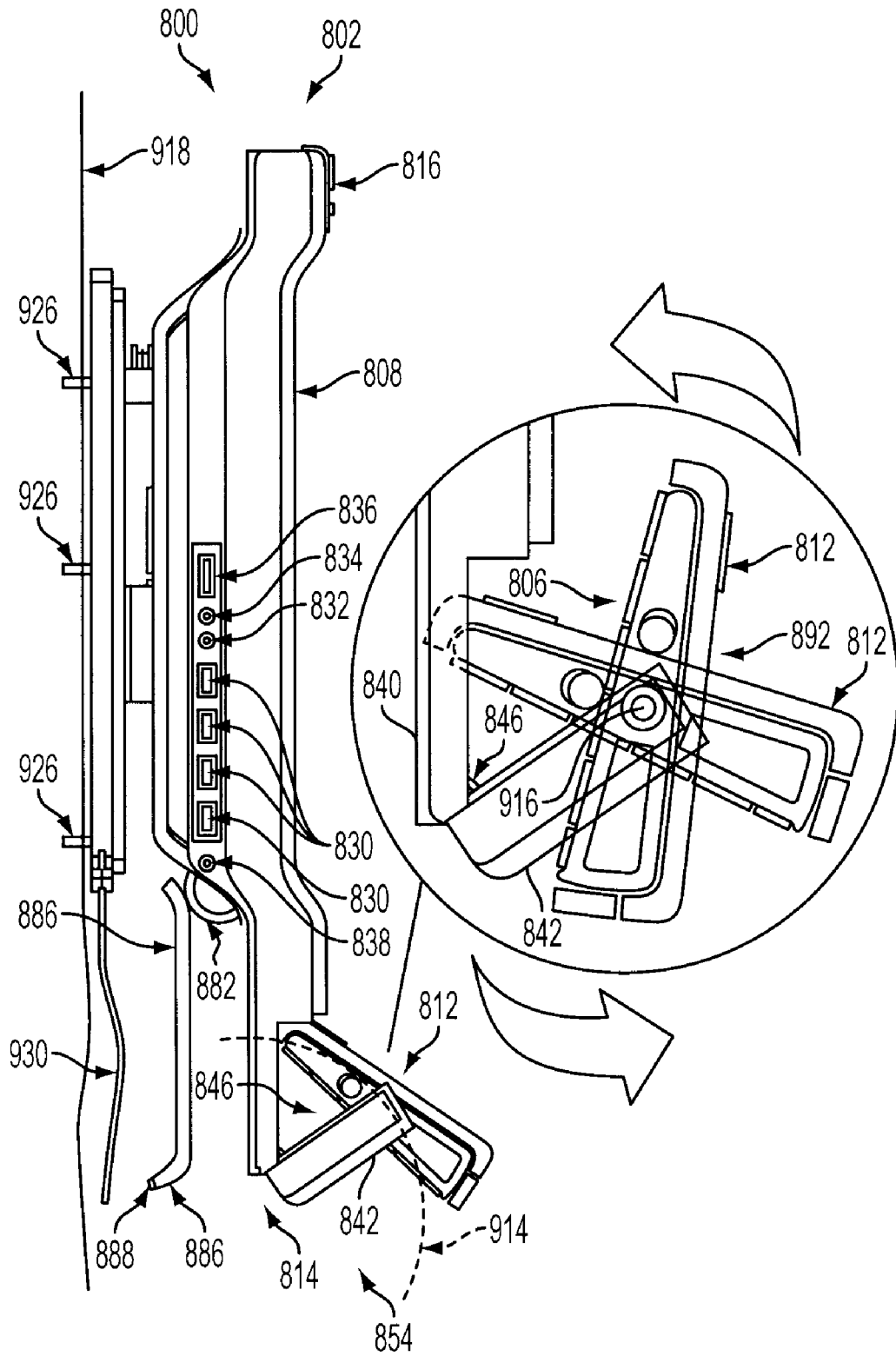

FIG. 53

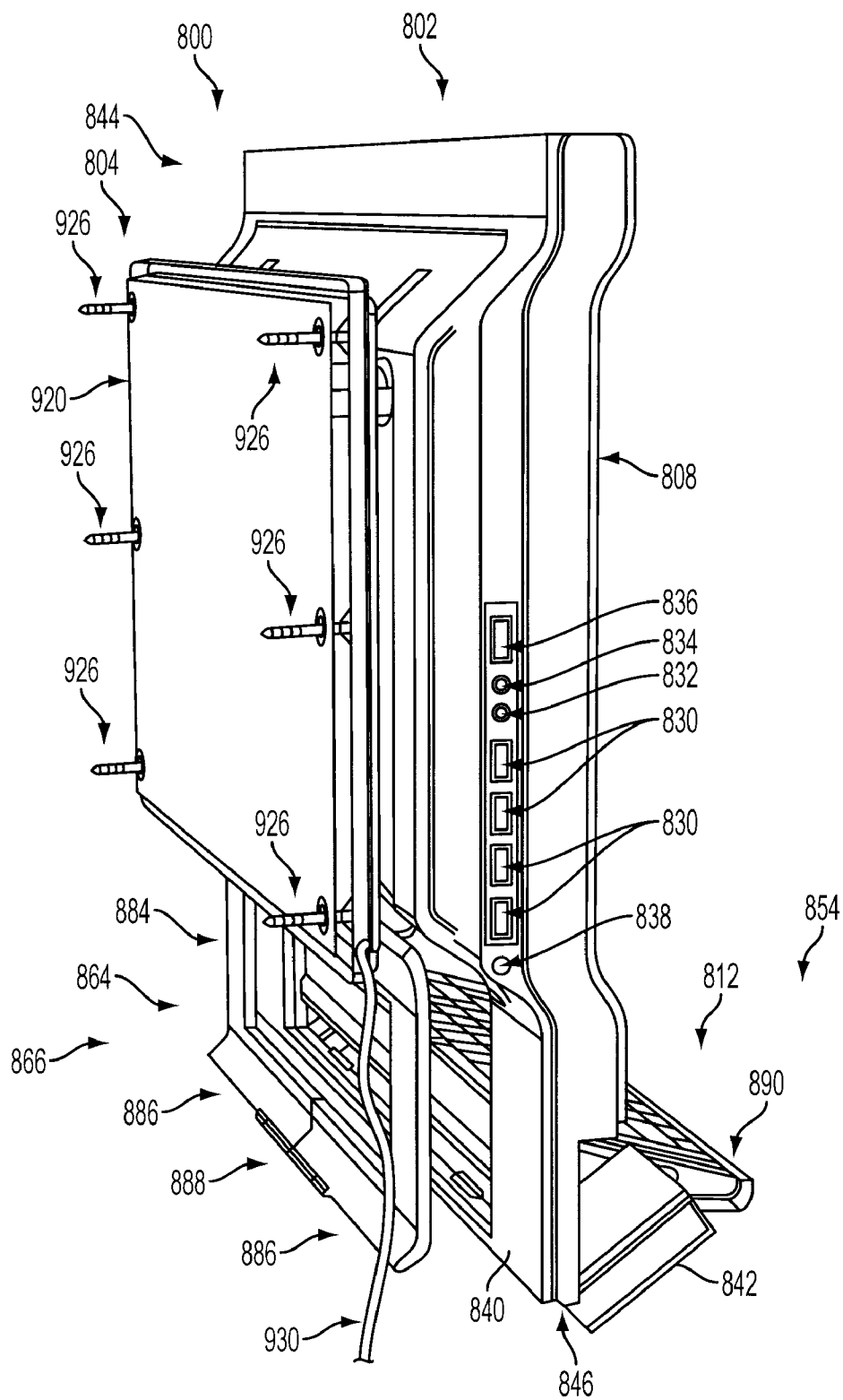

FIG. 54

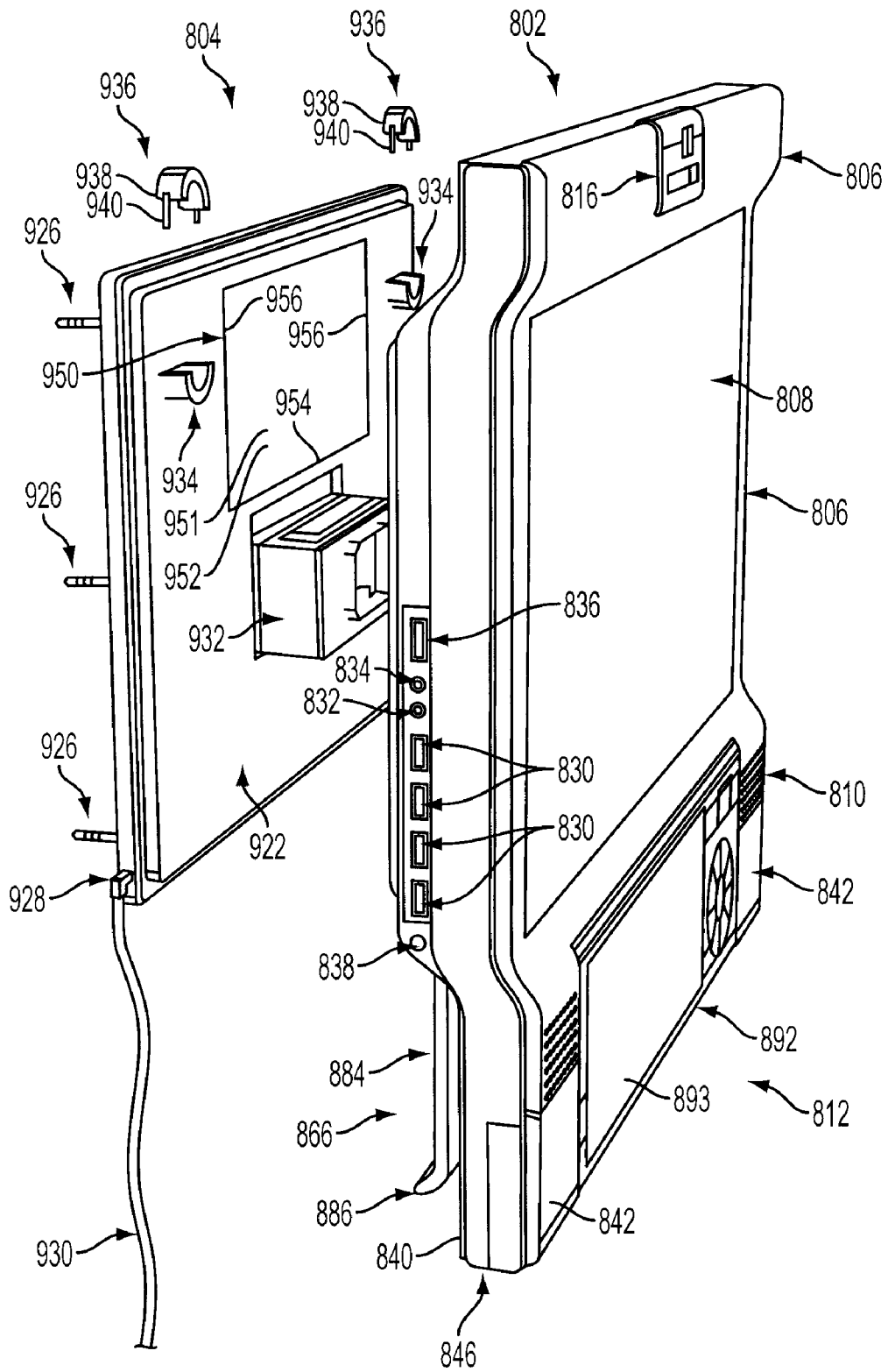

FIG. 55

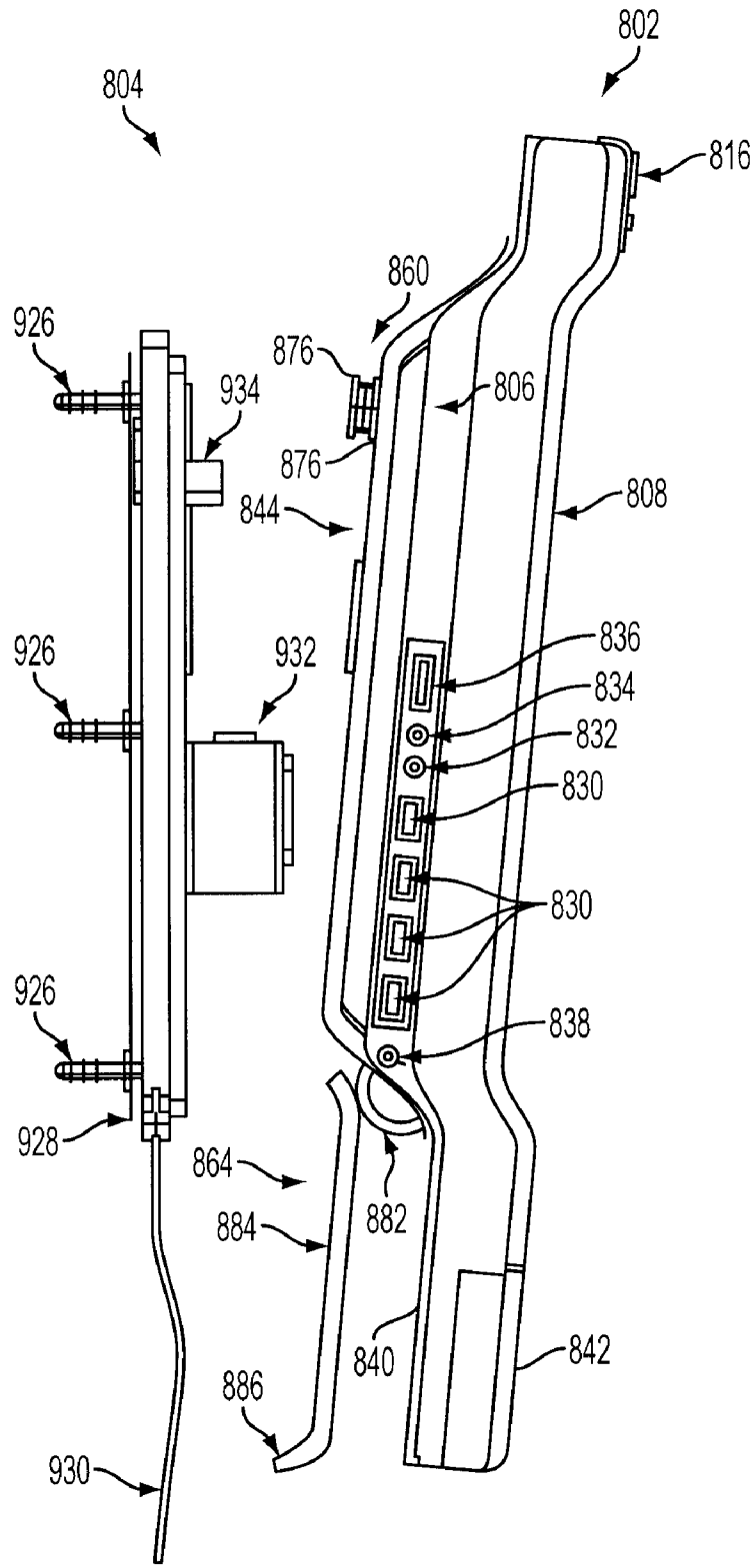

FIG. 56

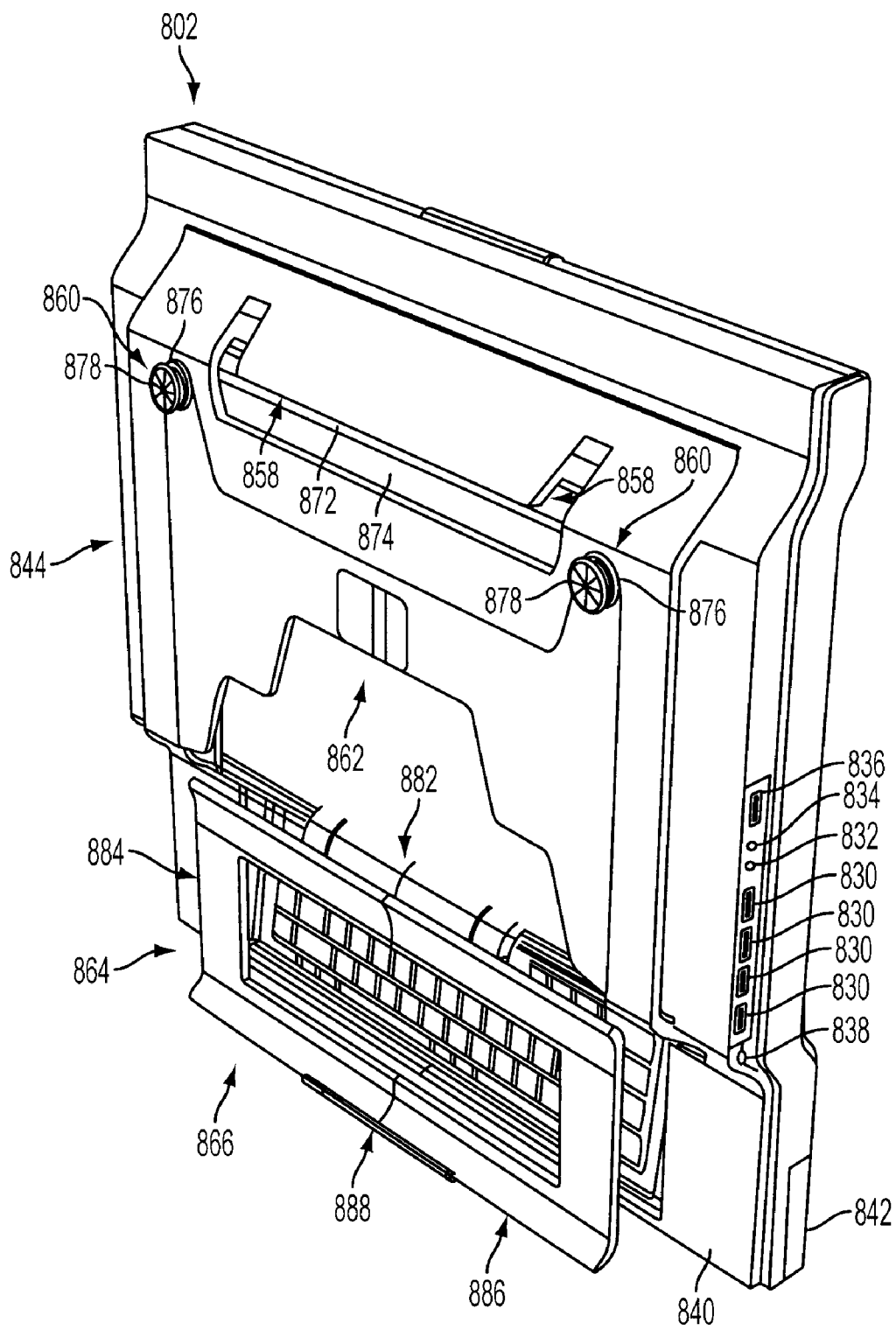

FIG. 57

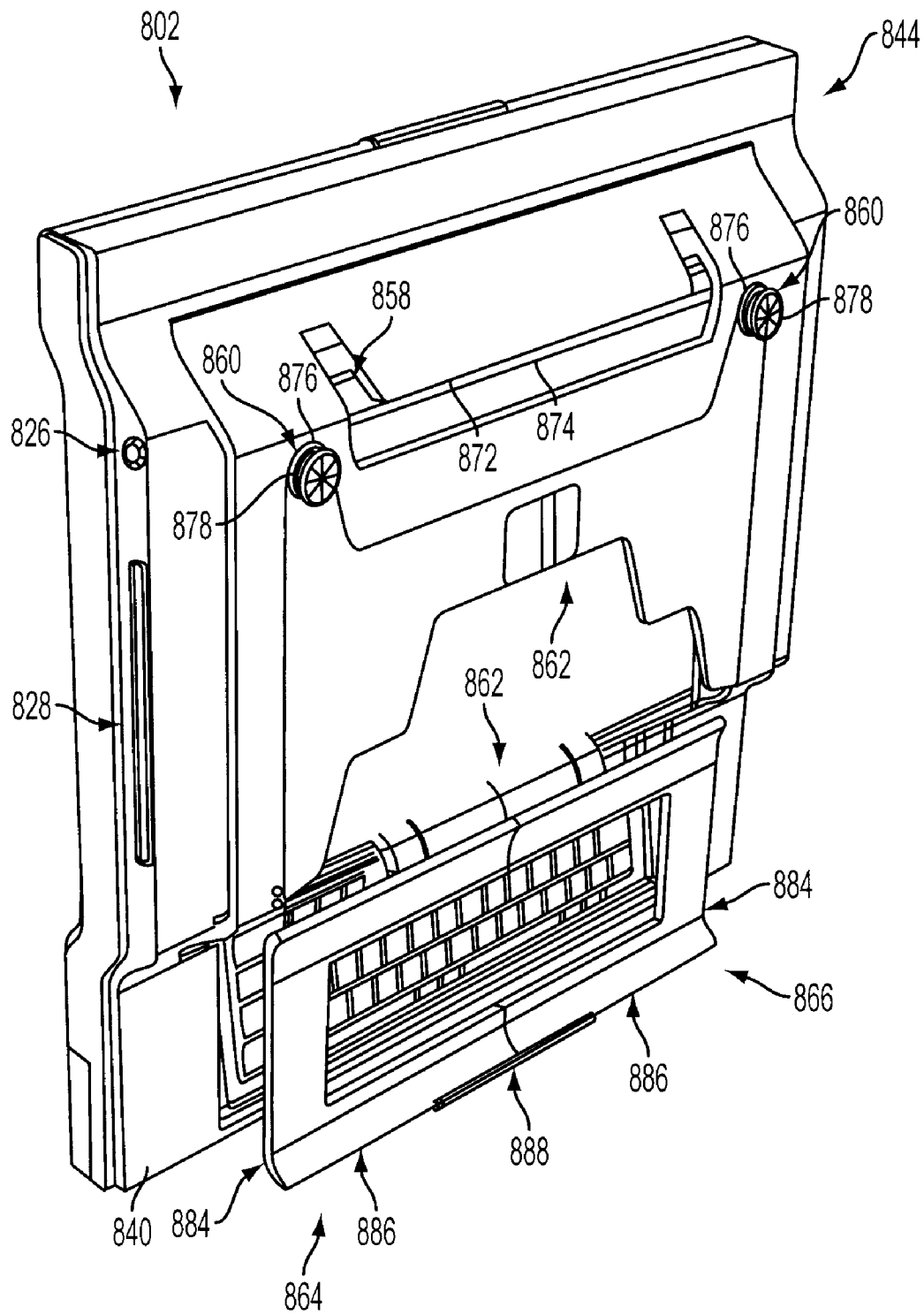

FIG. 58

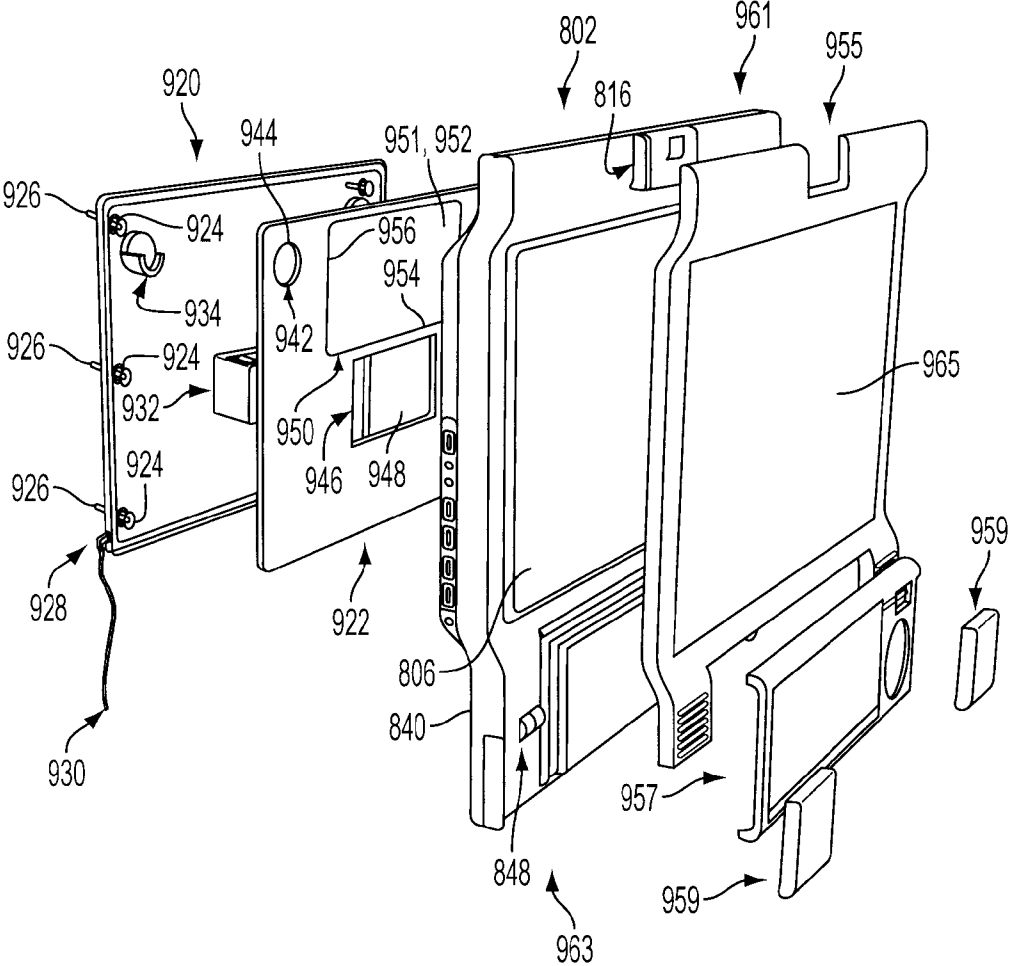

FIG. 59

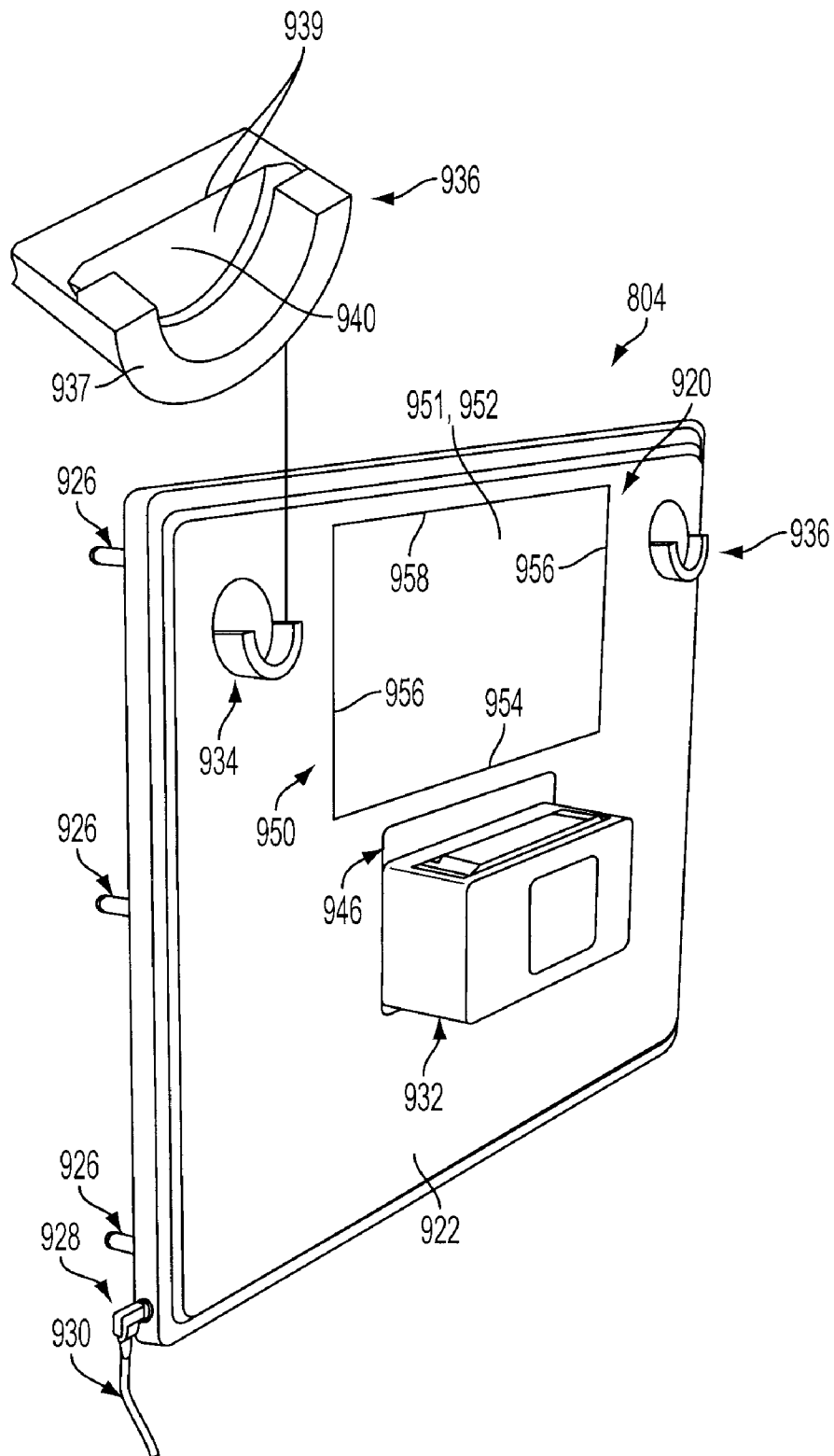

FIG. 60

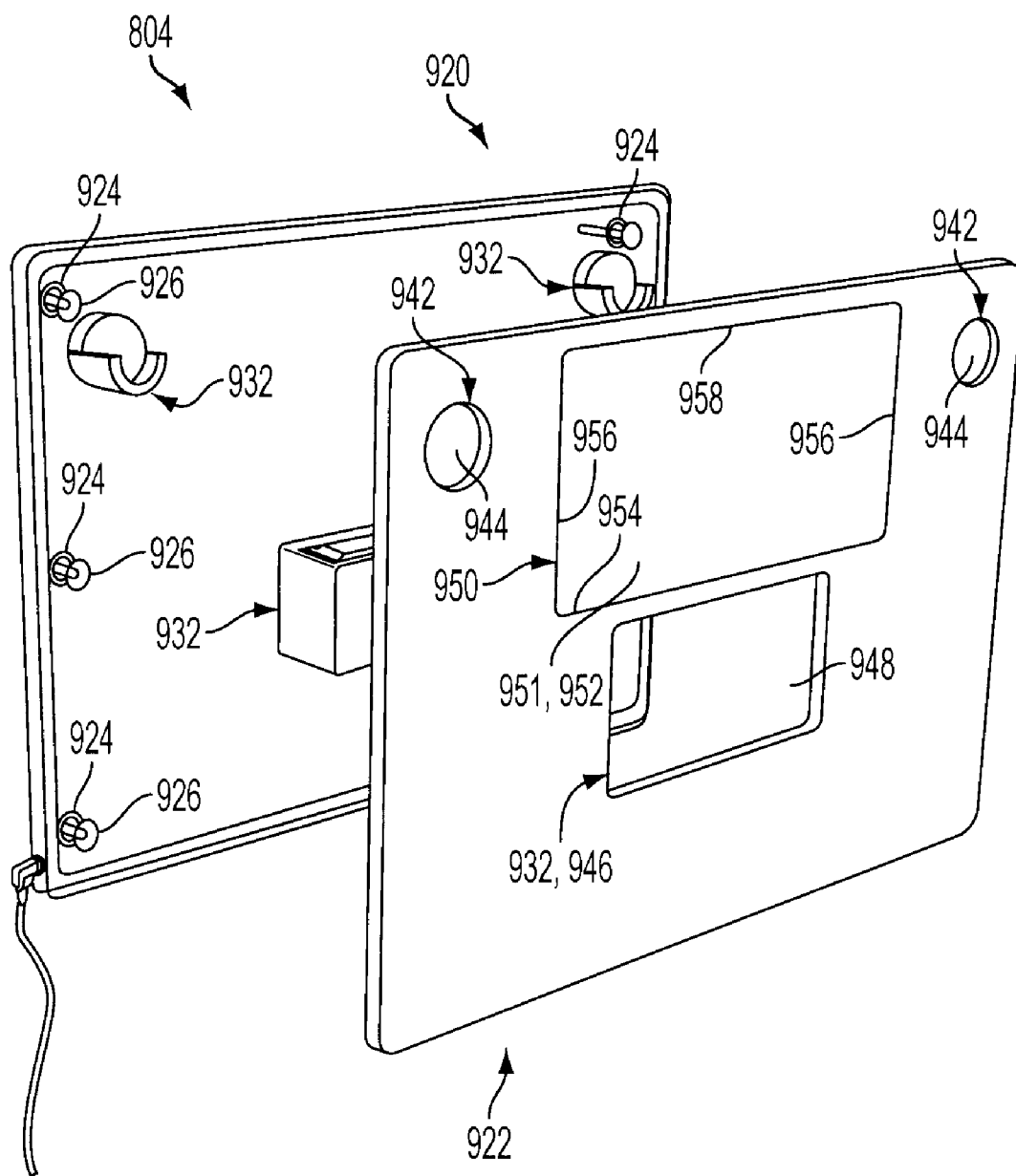

FIG. 61

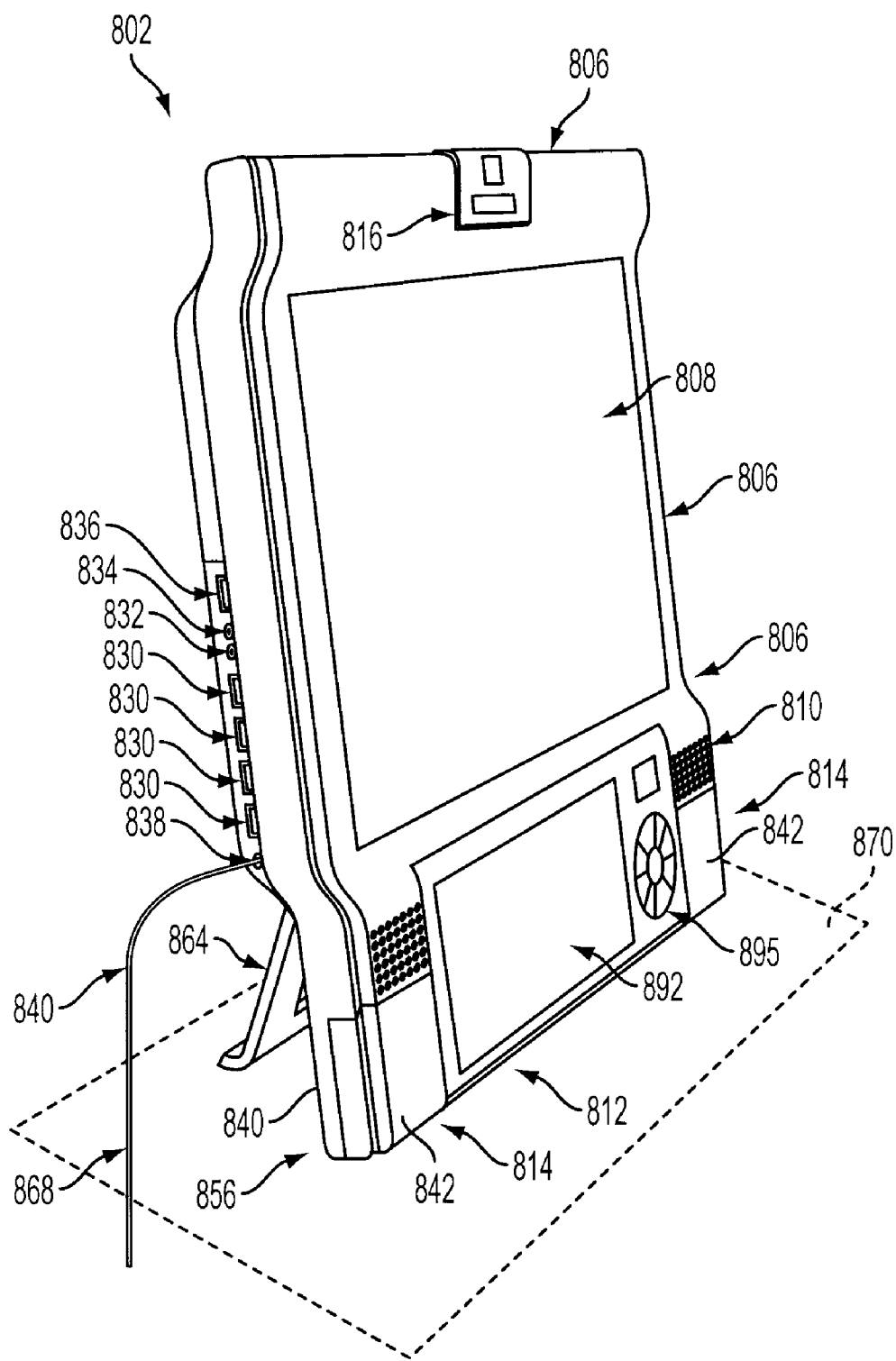

FIG. 62

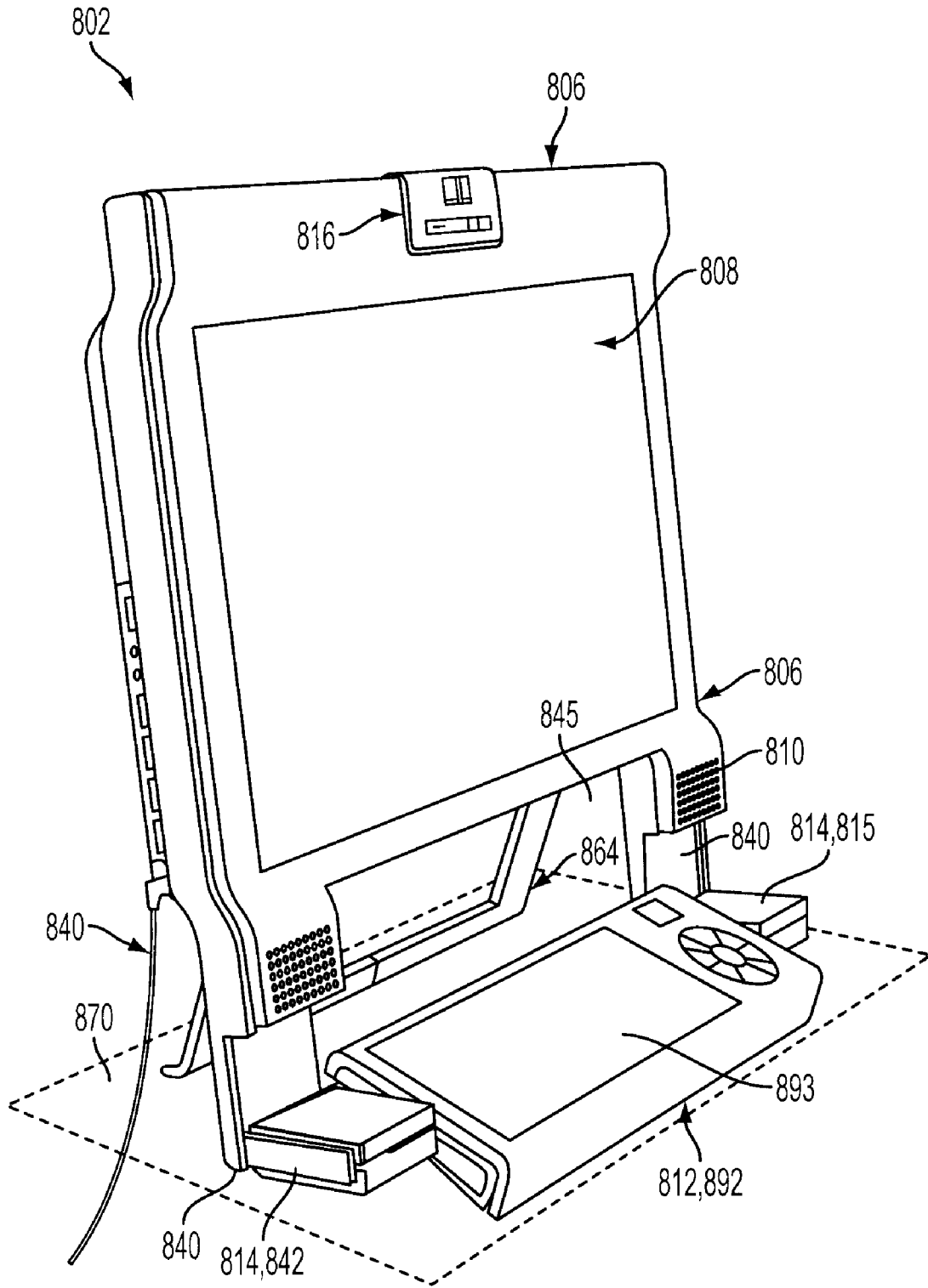

FIG. 66

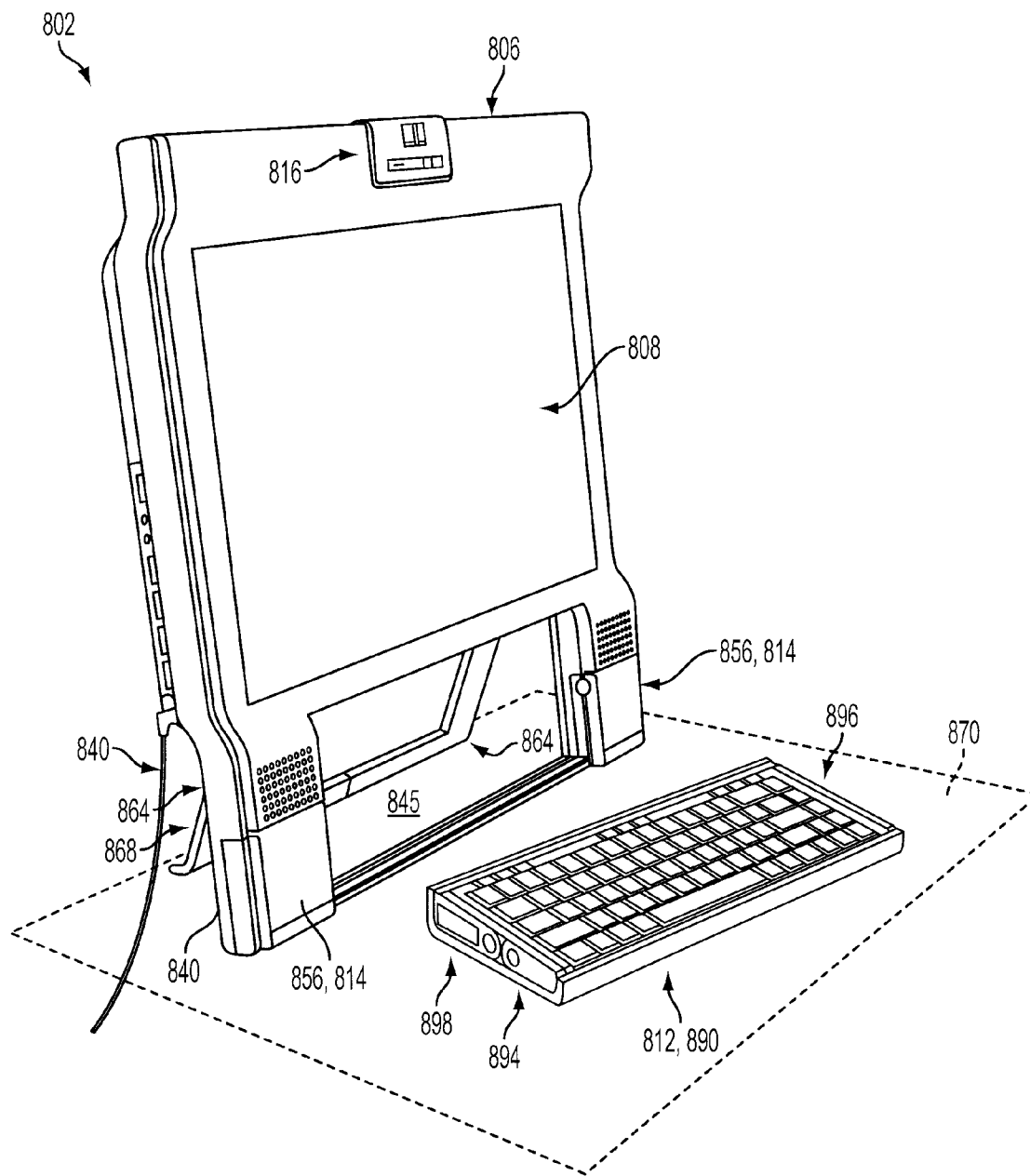

FIG. 67

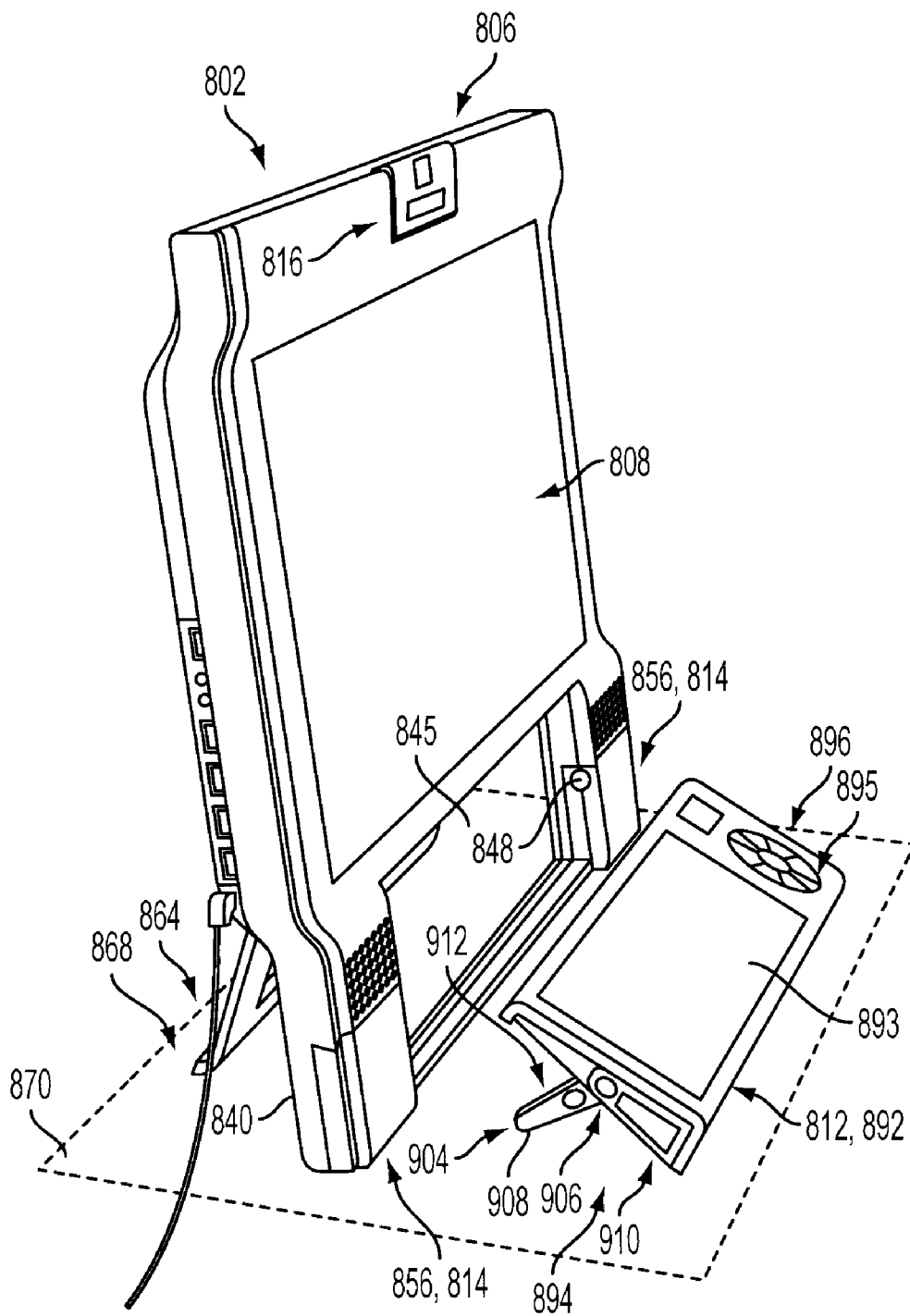

FIG. 68

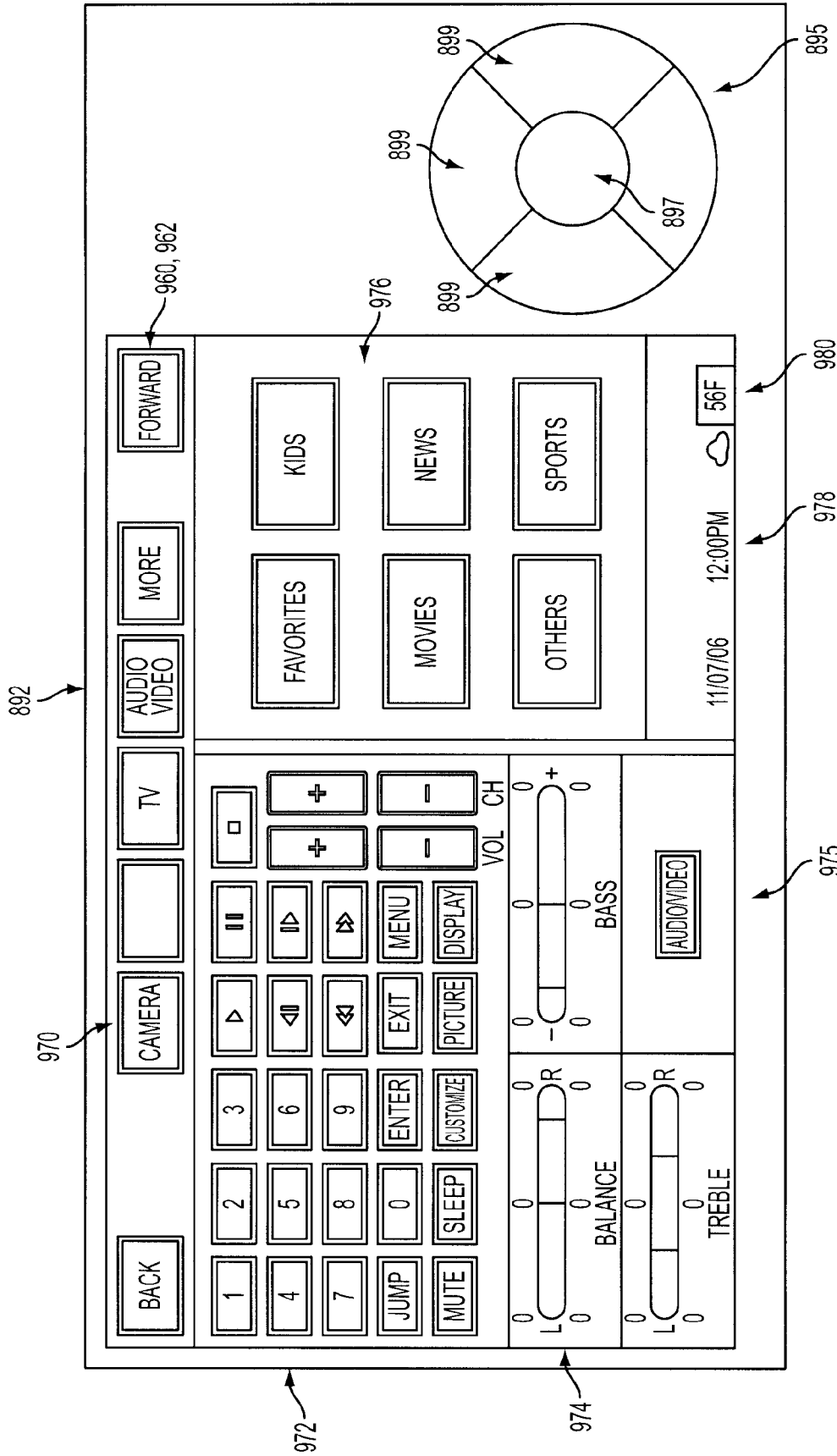

FIG. 69

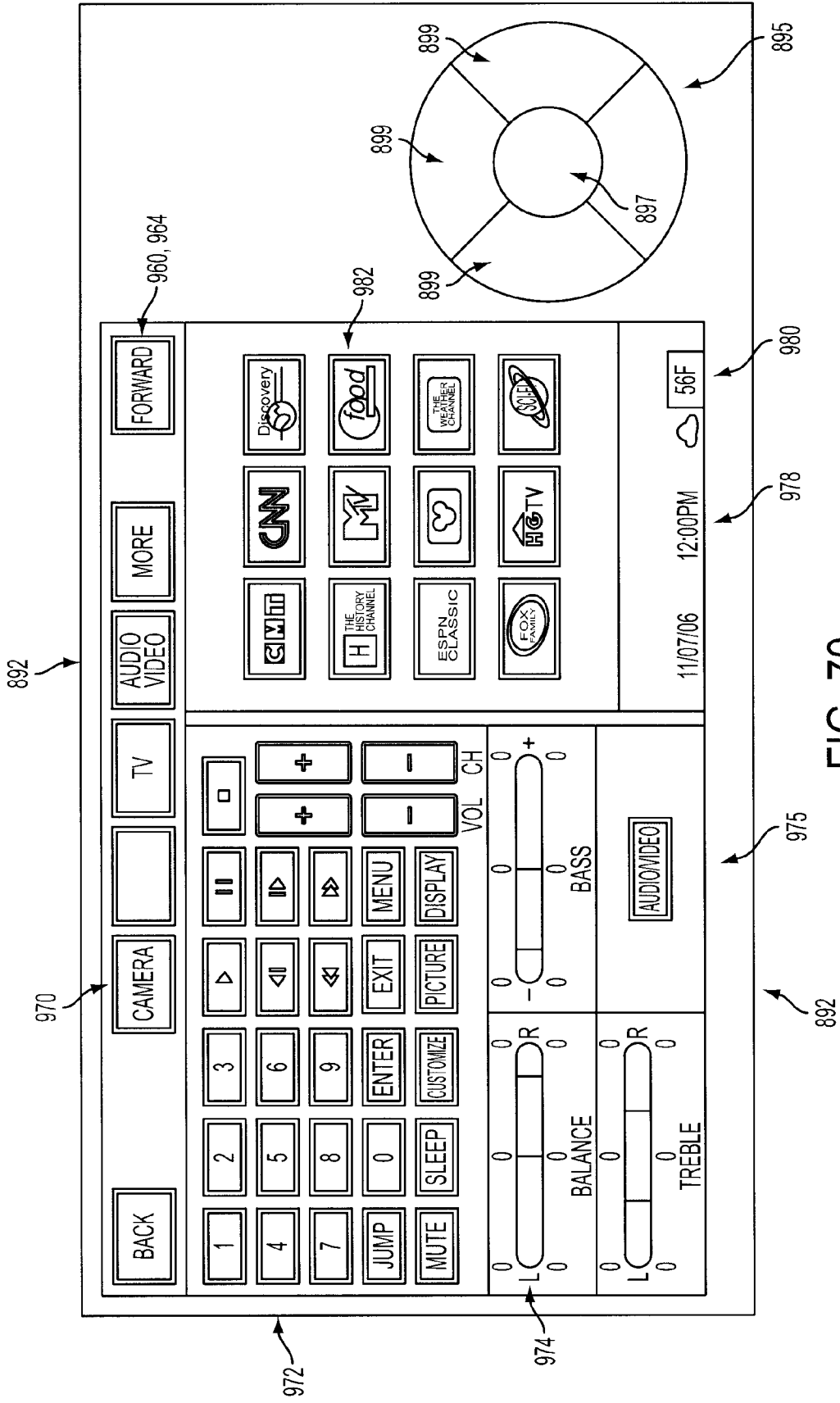

FIG. 70

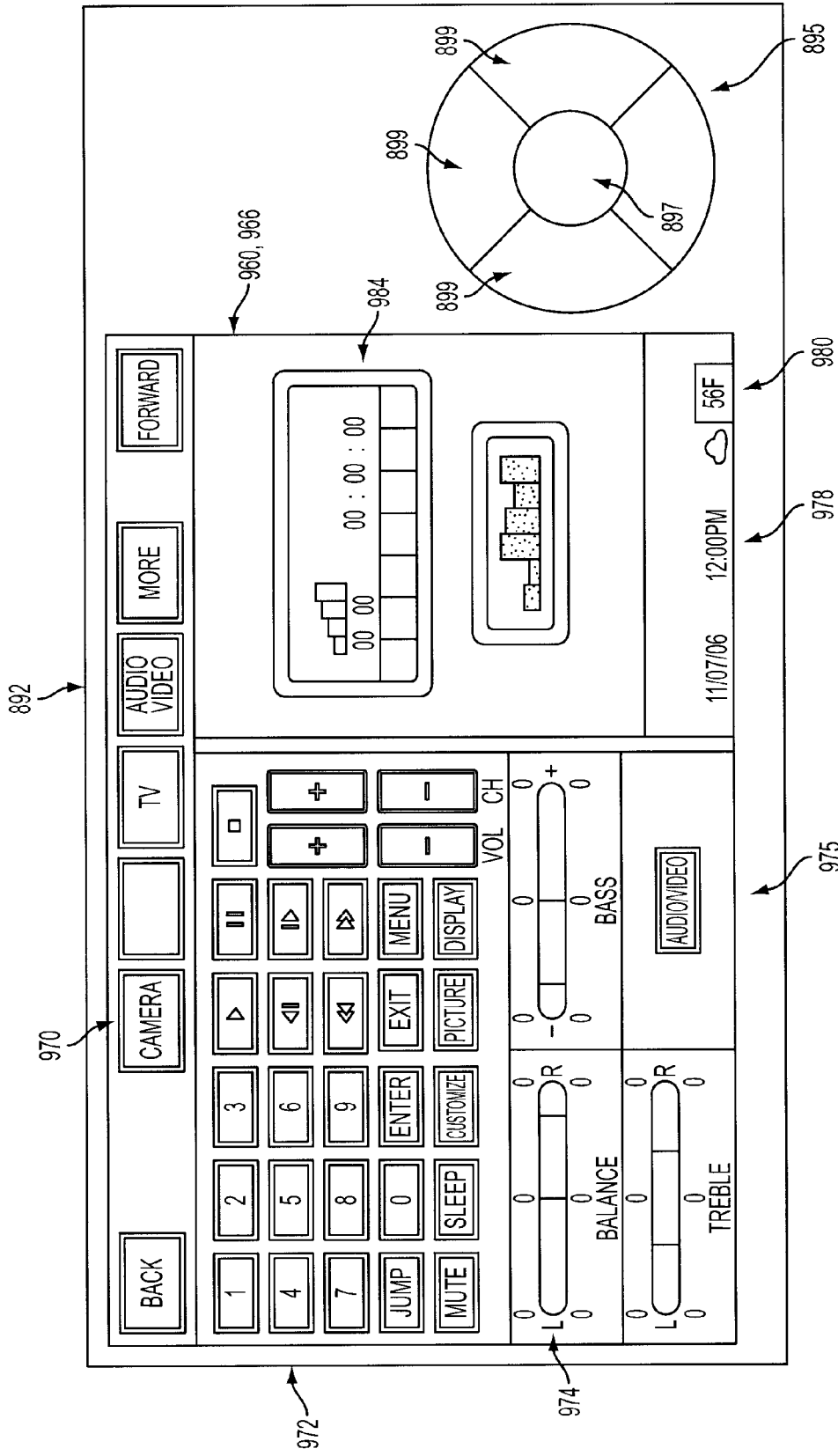

FIG. 71

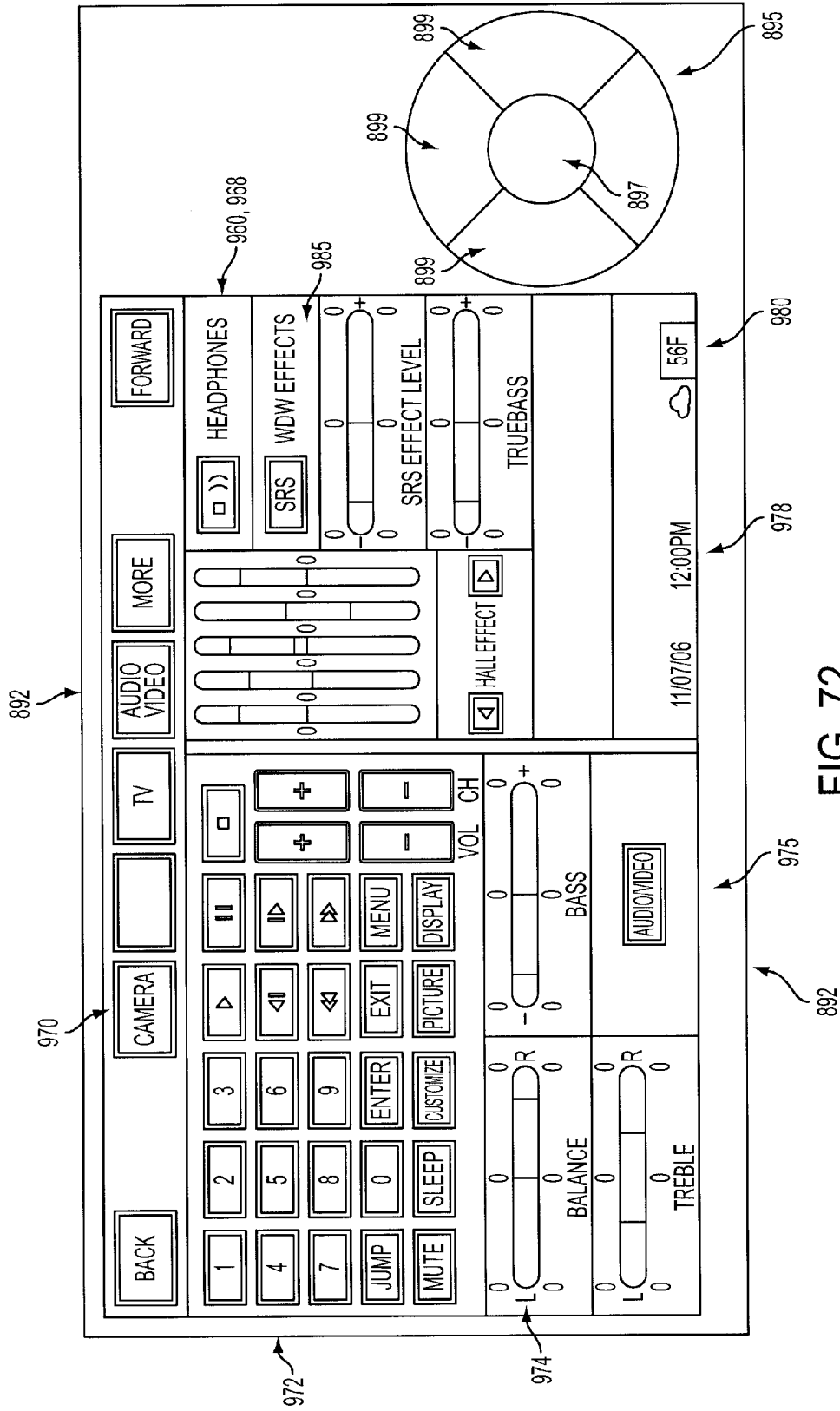

FIG. 72

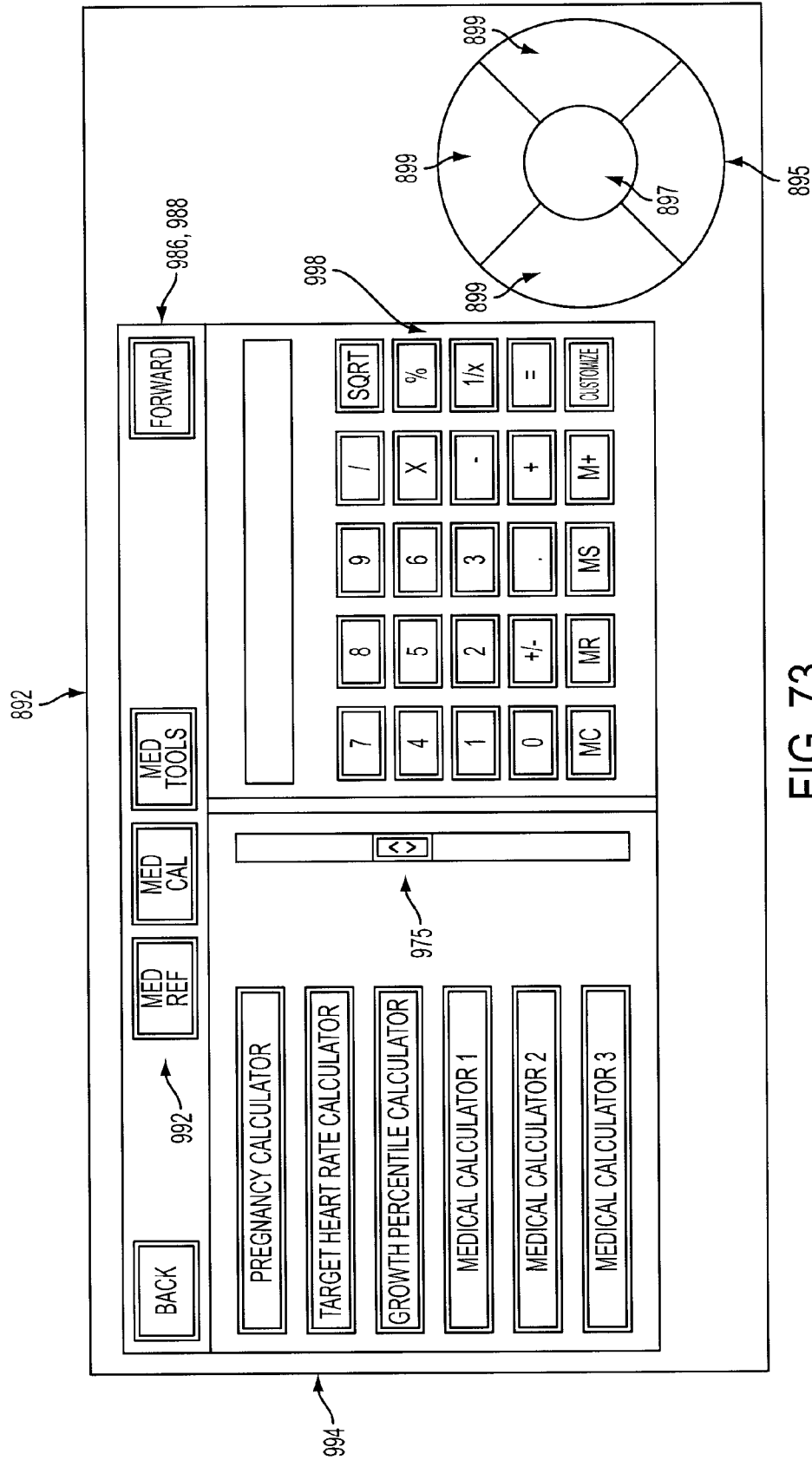

FIG. 73

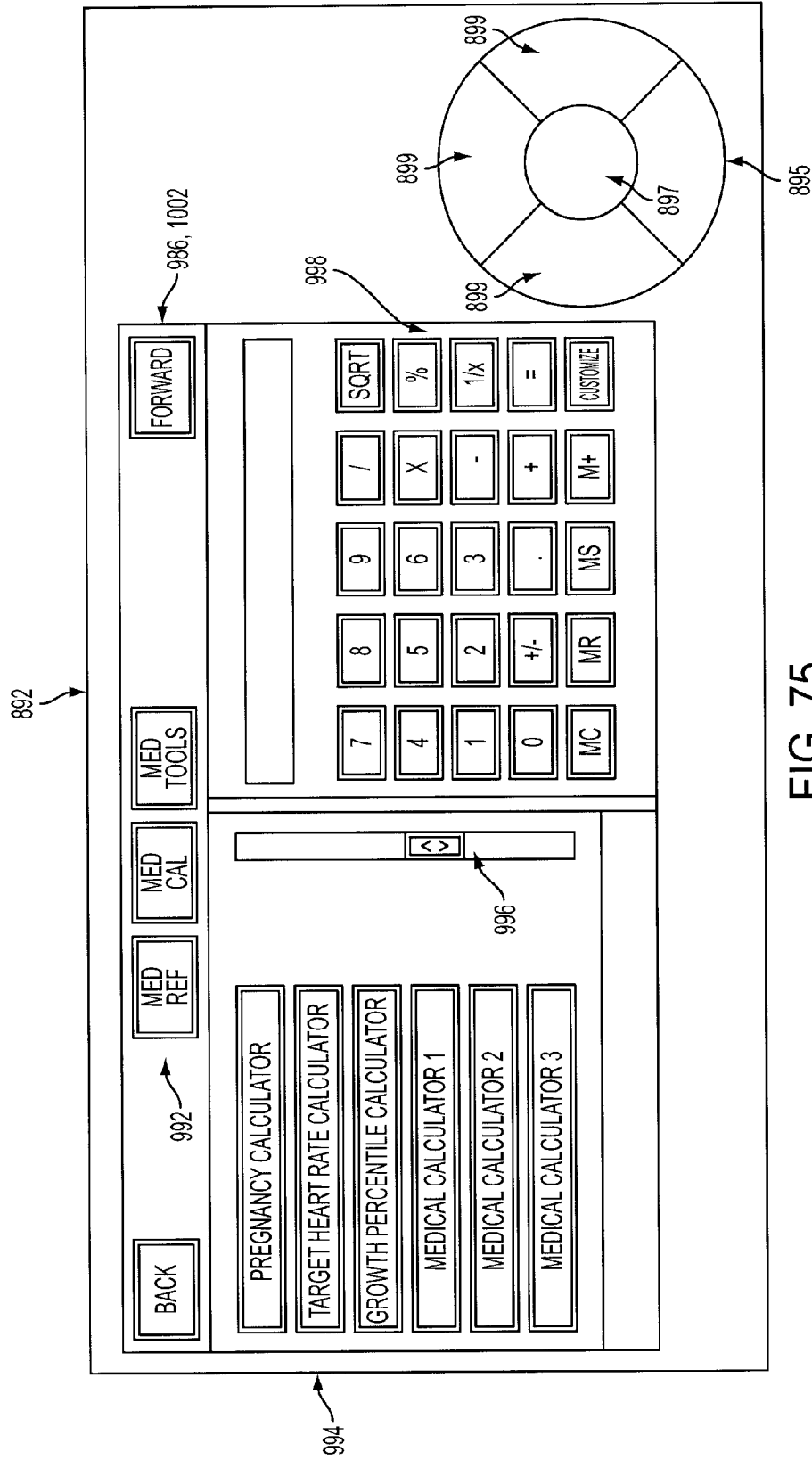

FIG. 75

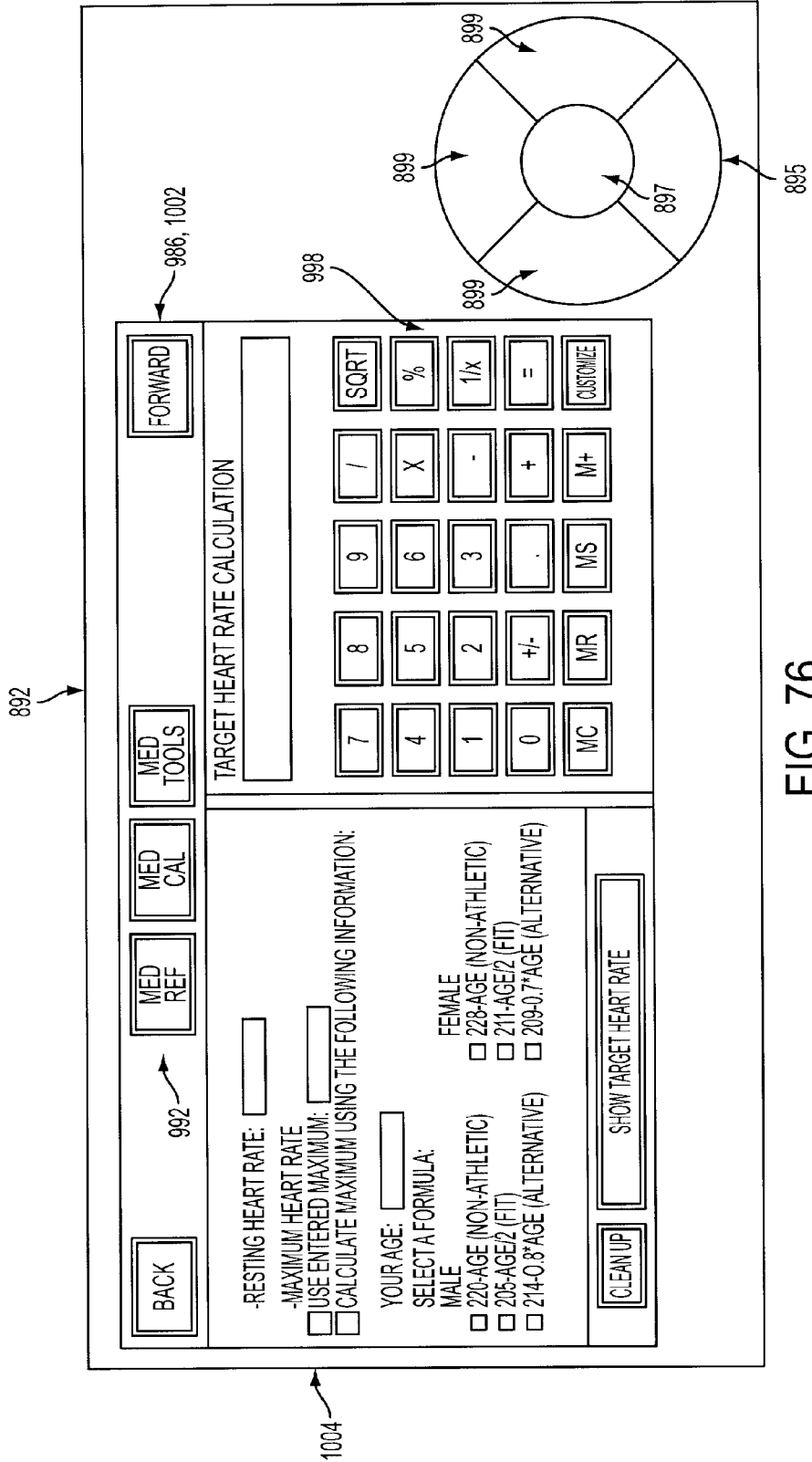

FIG. 76

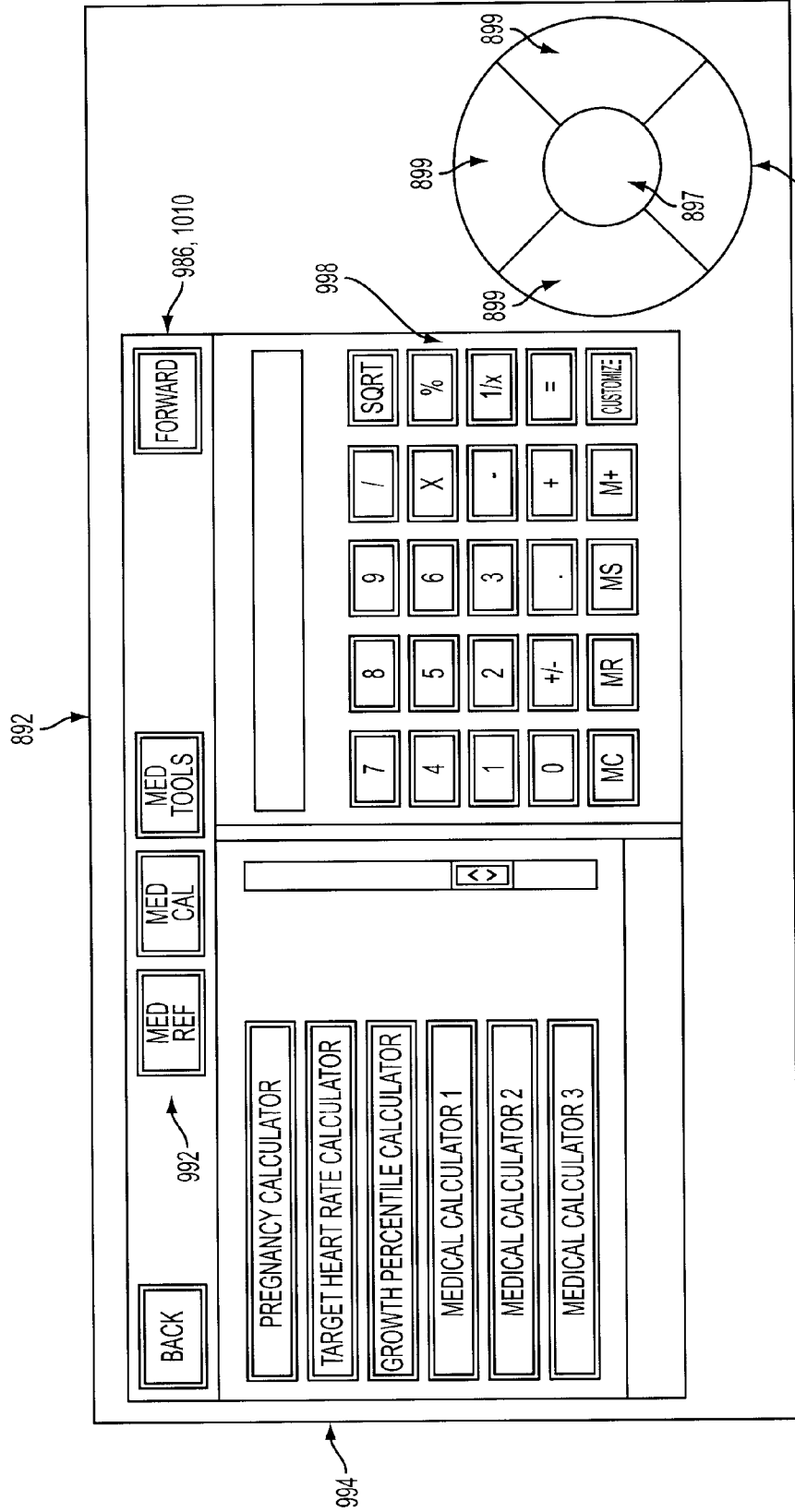

FIG. 78

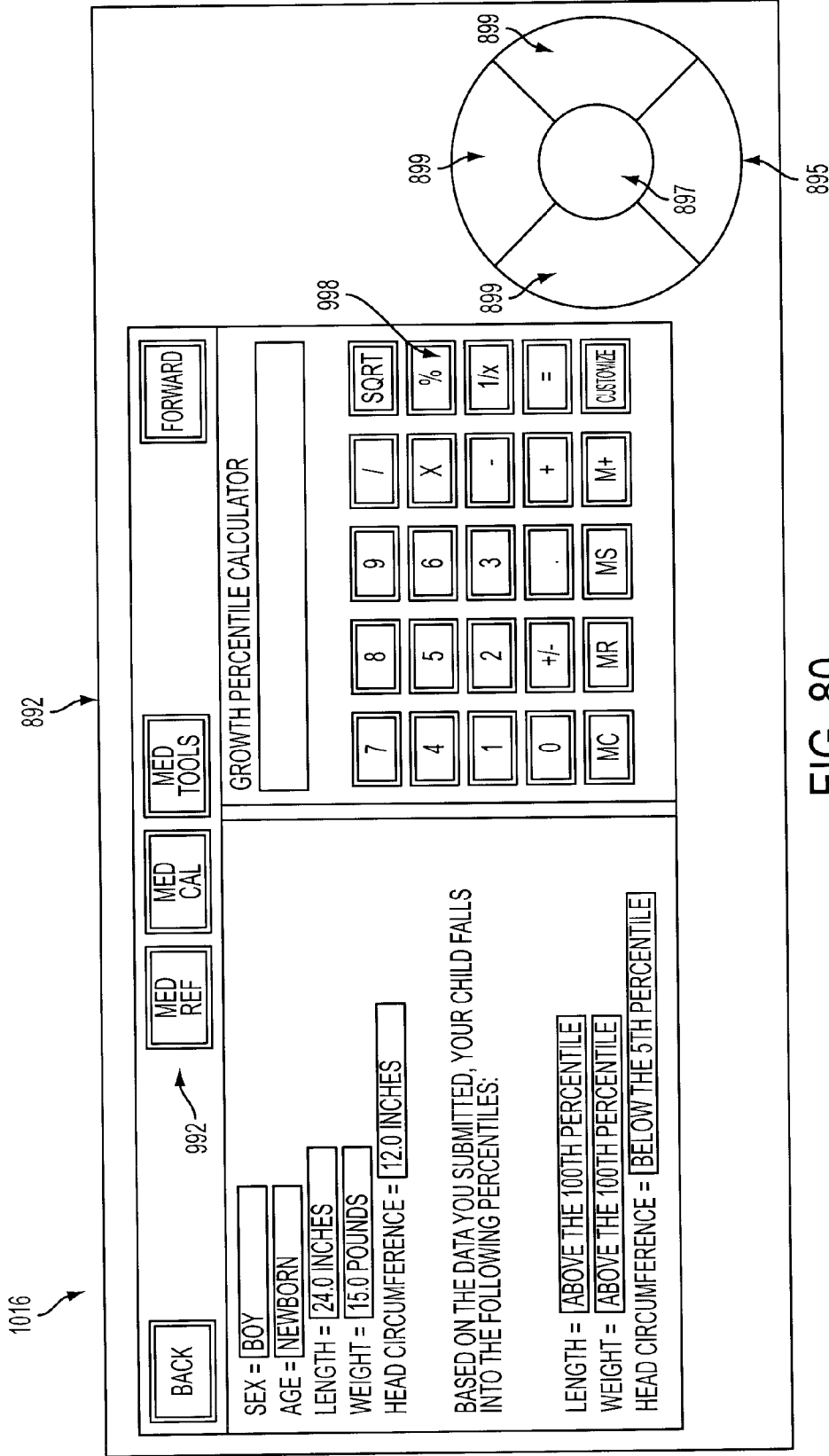

FIG. 80

FIG. 81

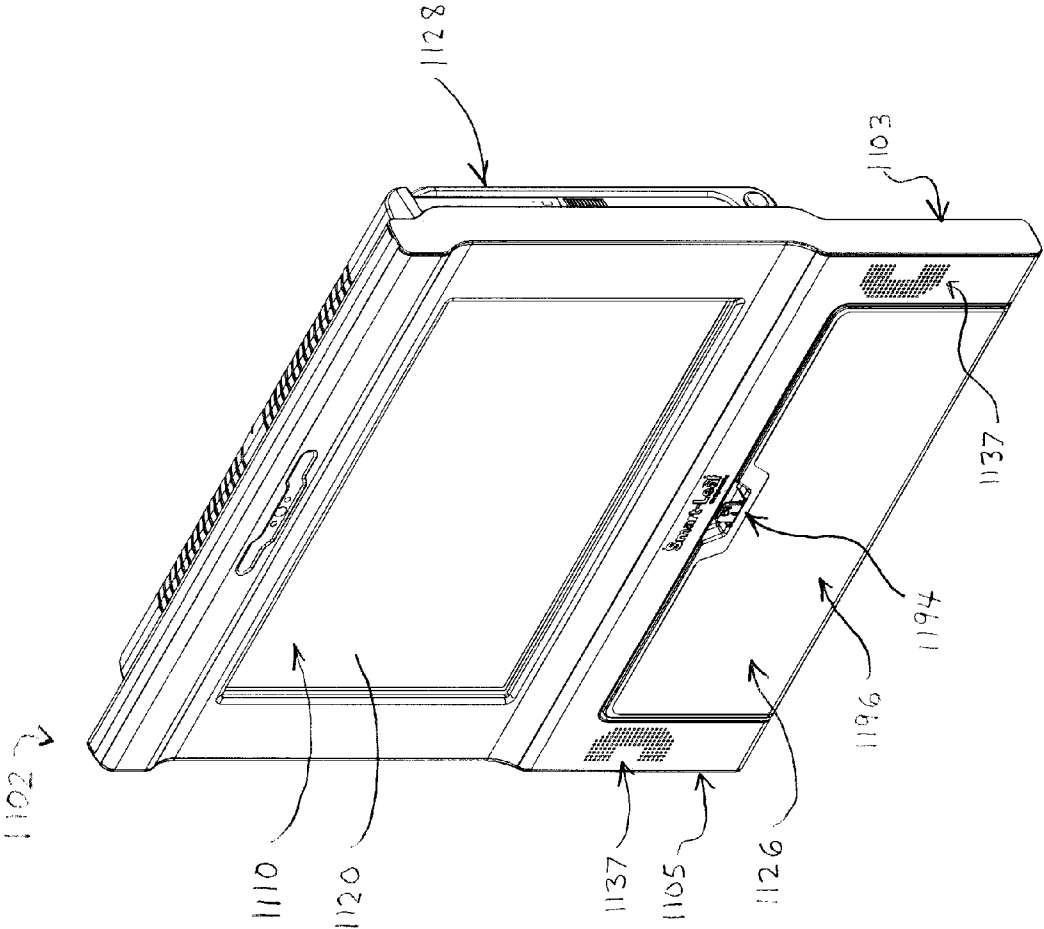

FIG. 82

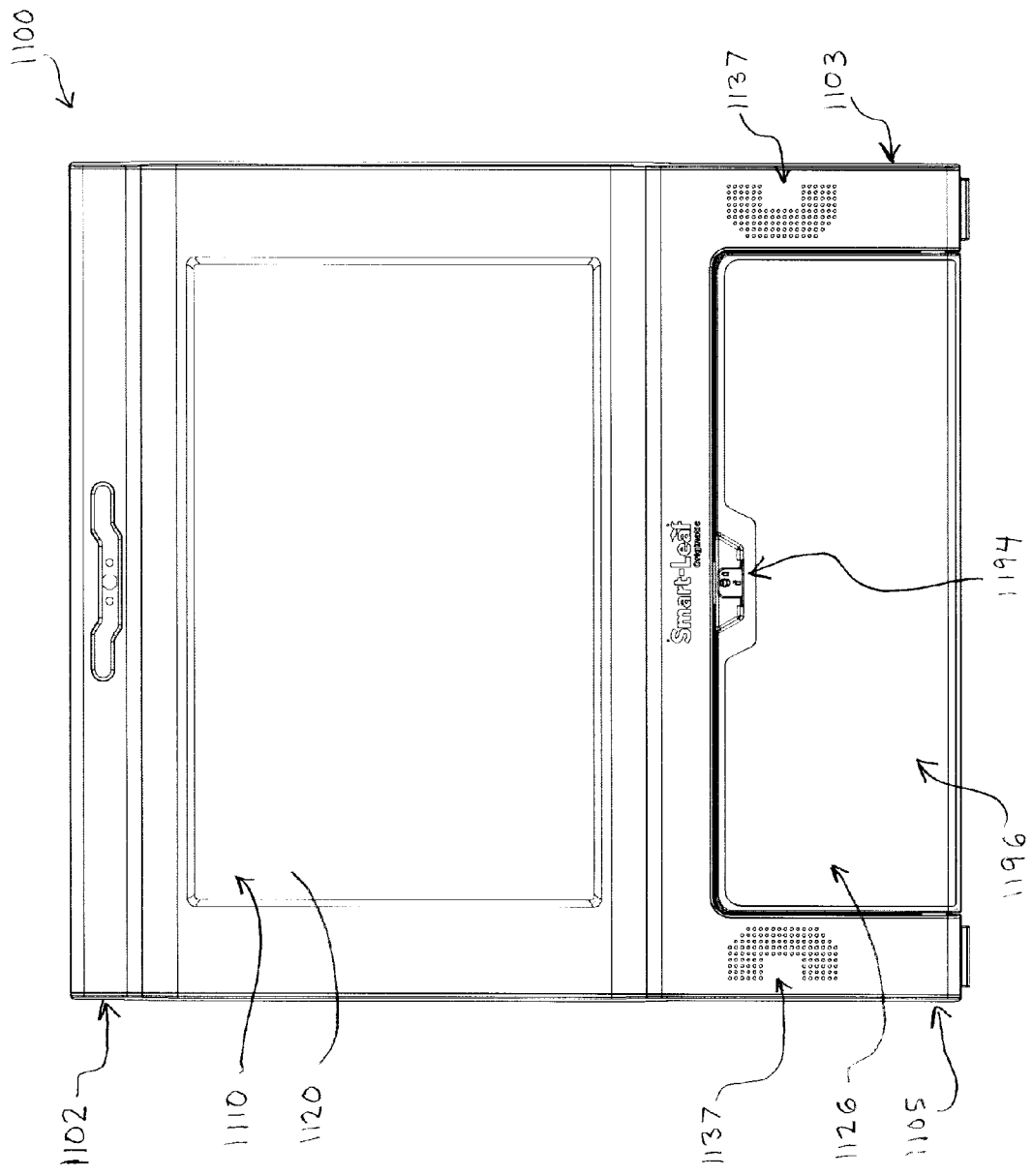

FIG. 83

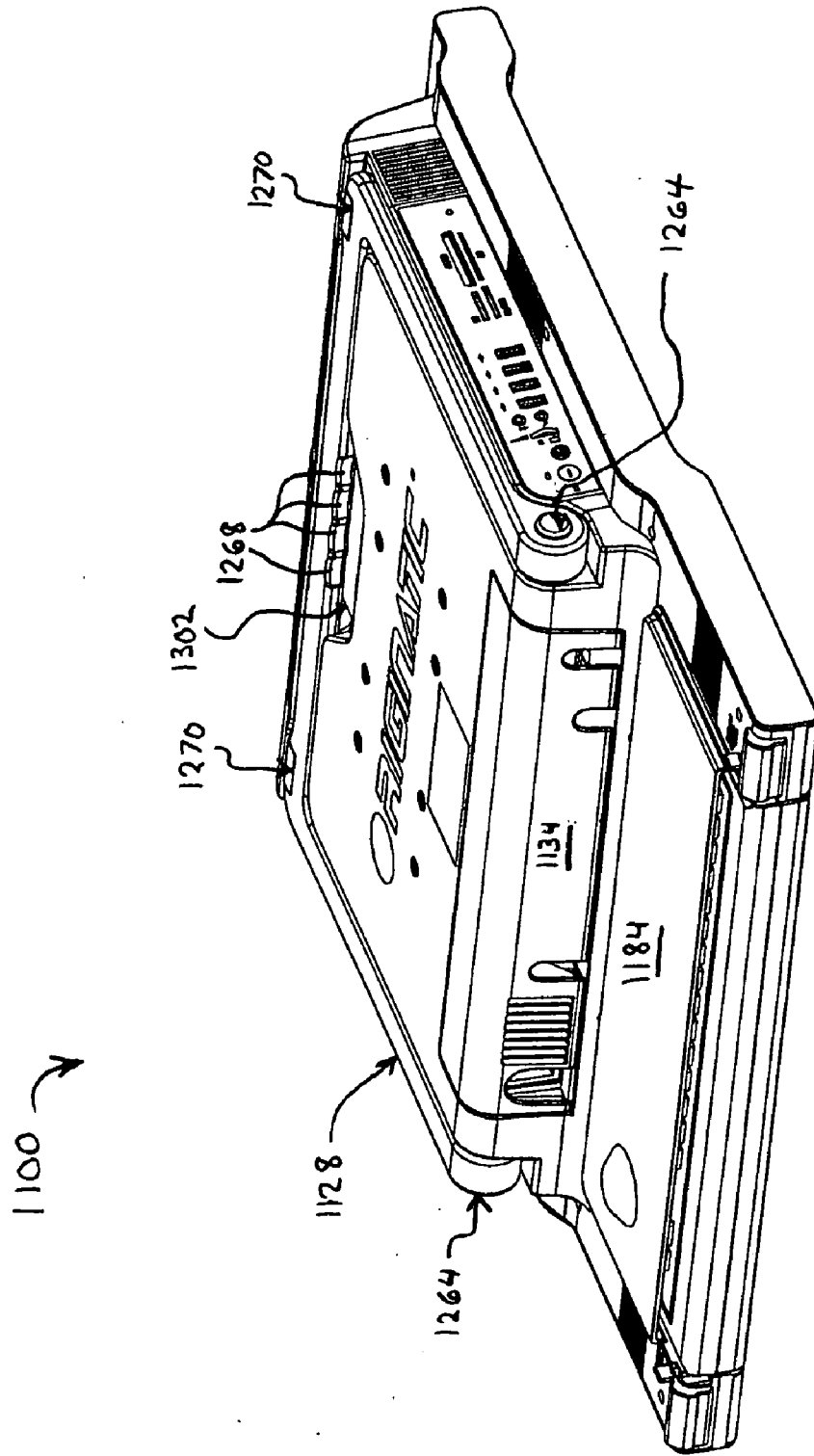

FIG. 84

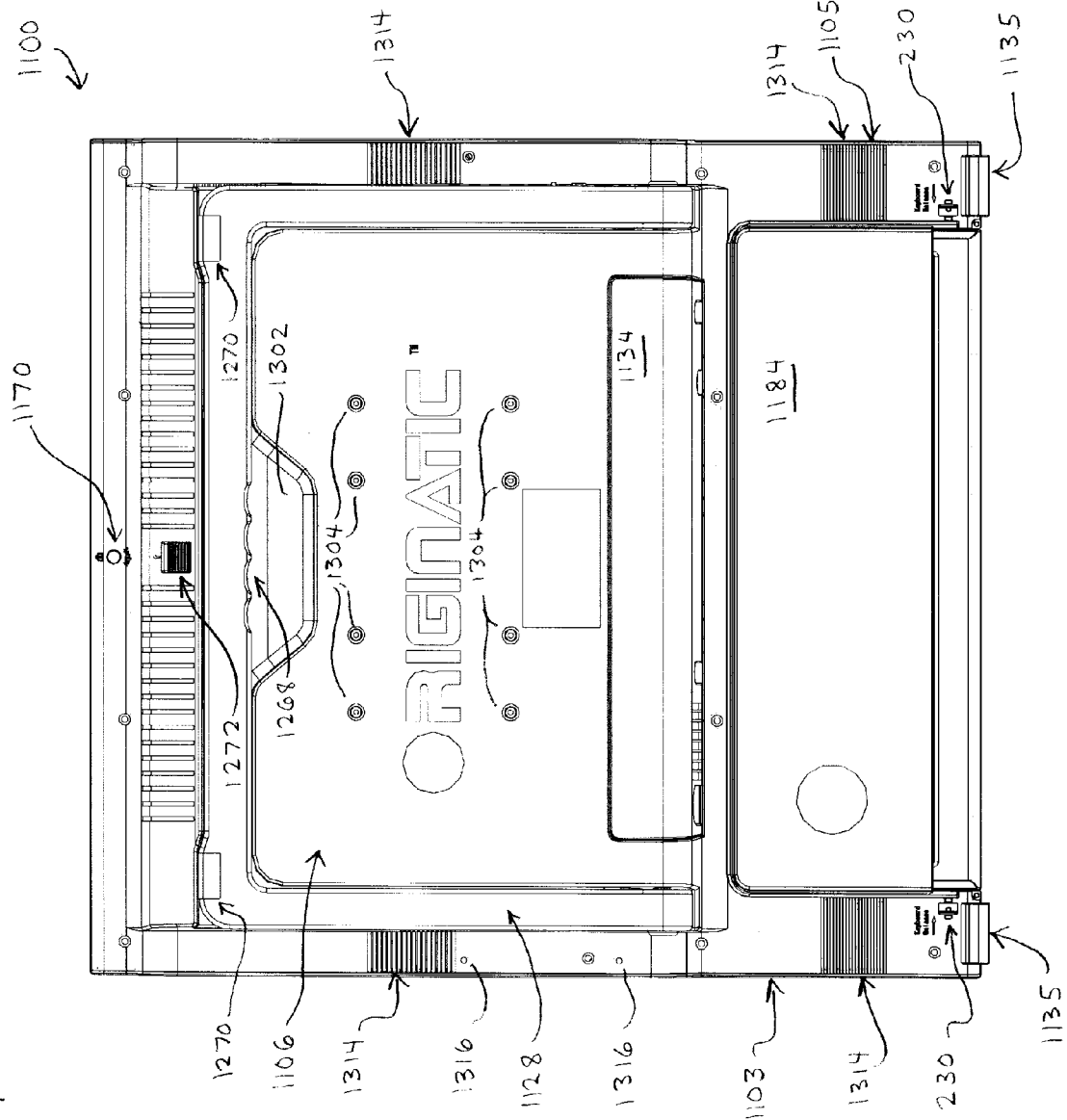

FIG. 85

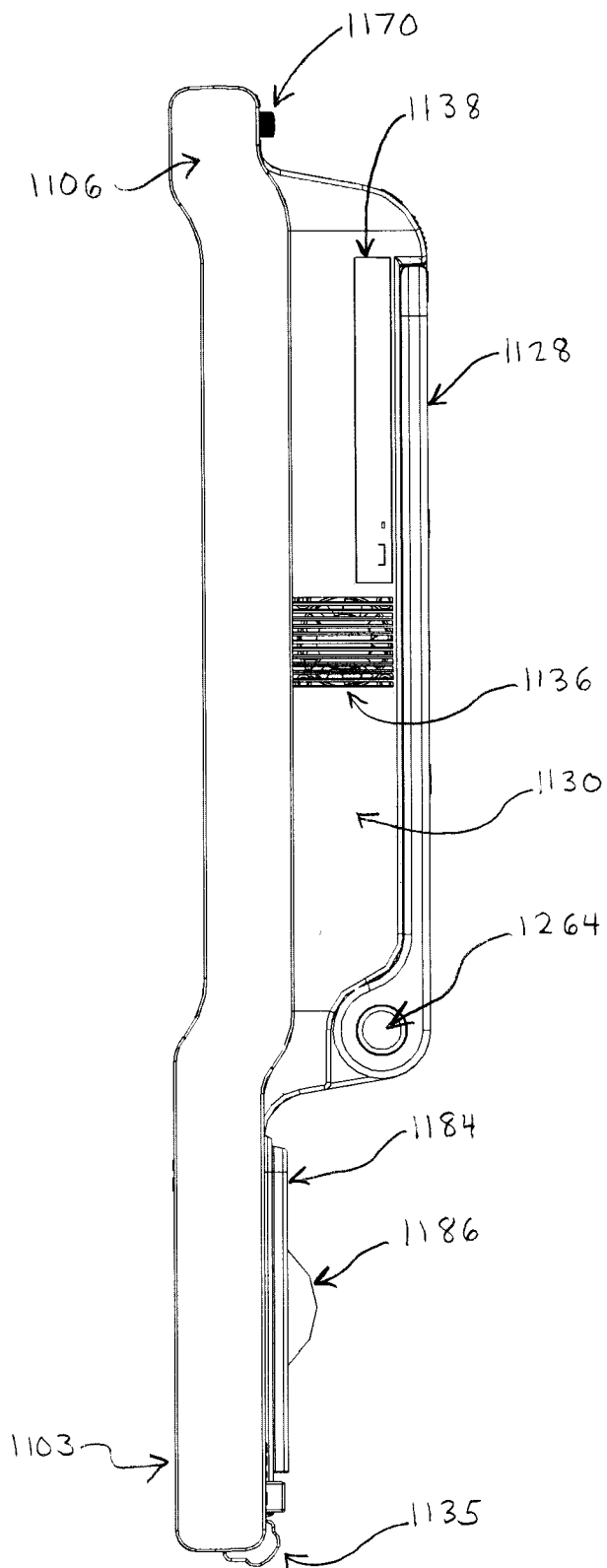

FIG. 86

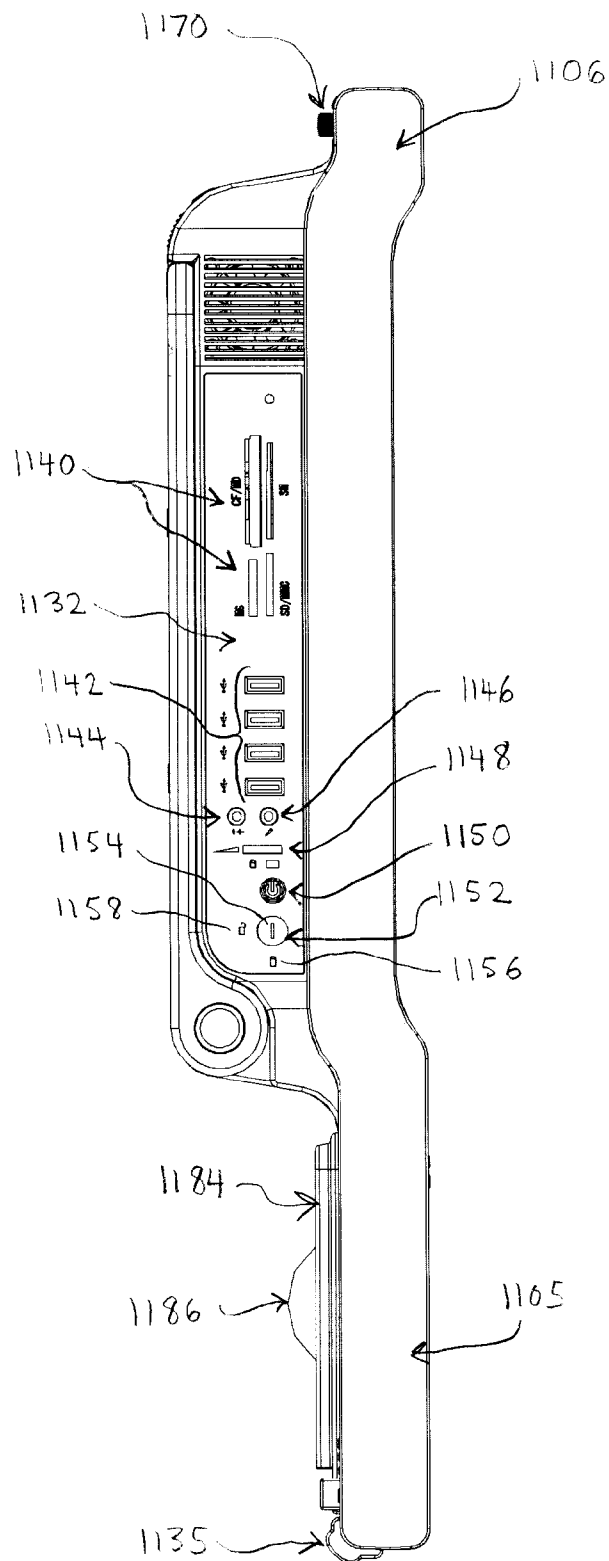

FIG. 87

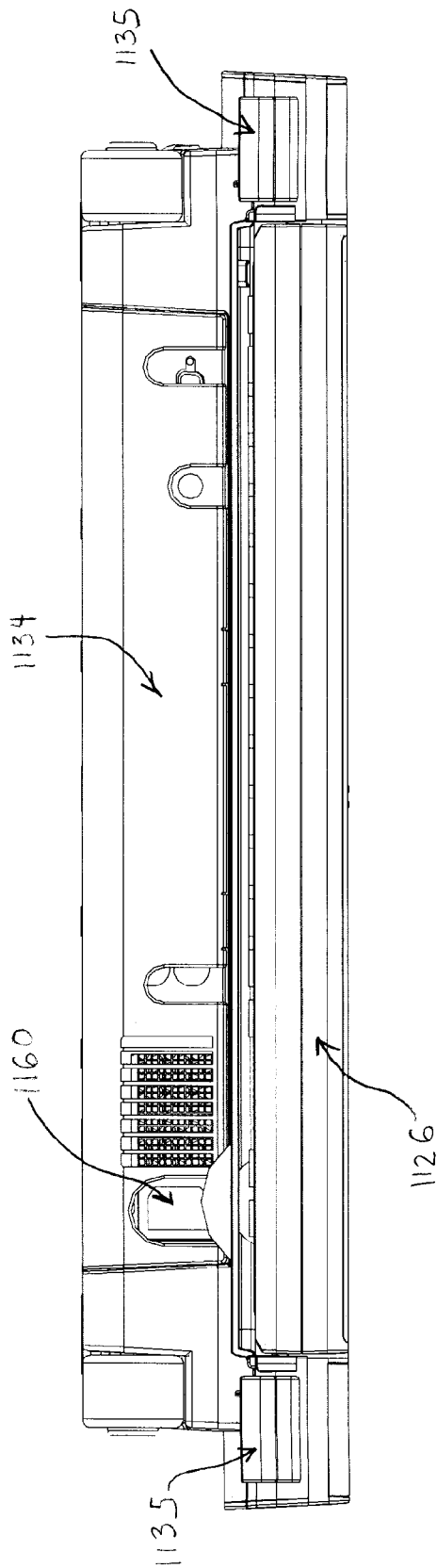

FIG. 88

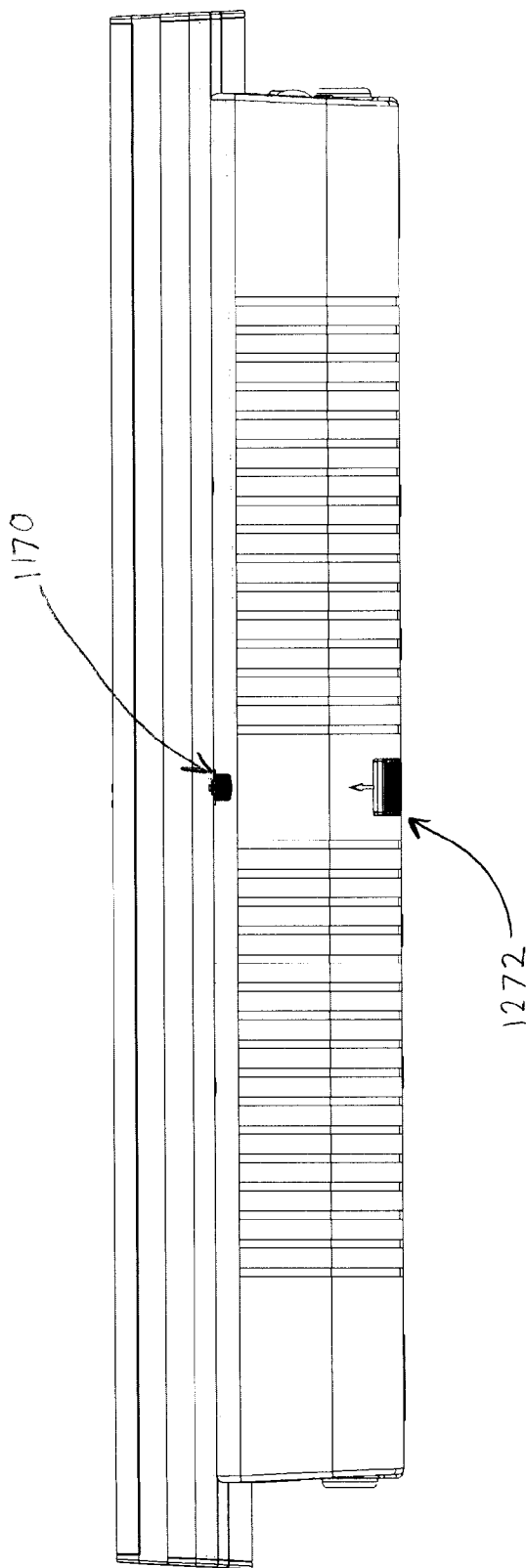
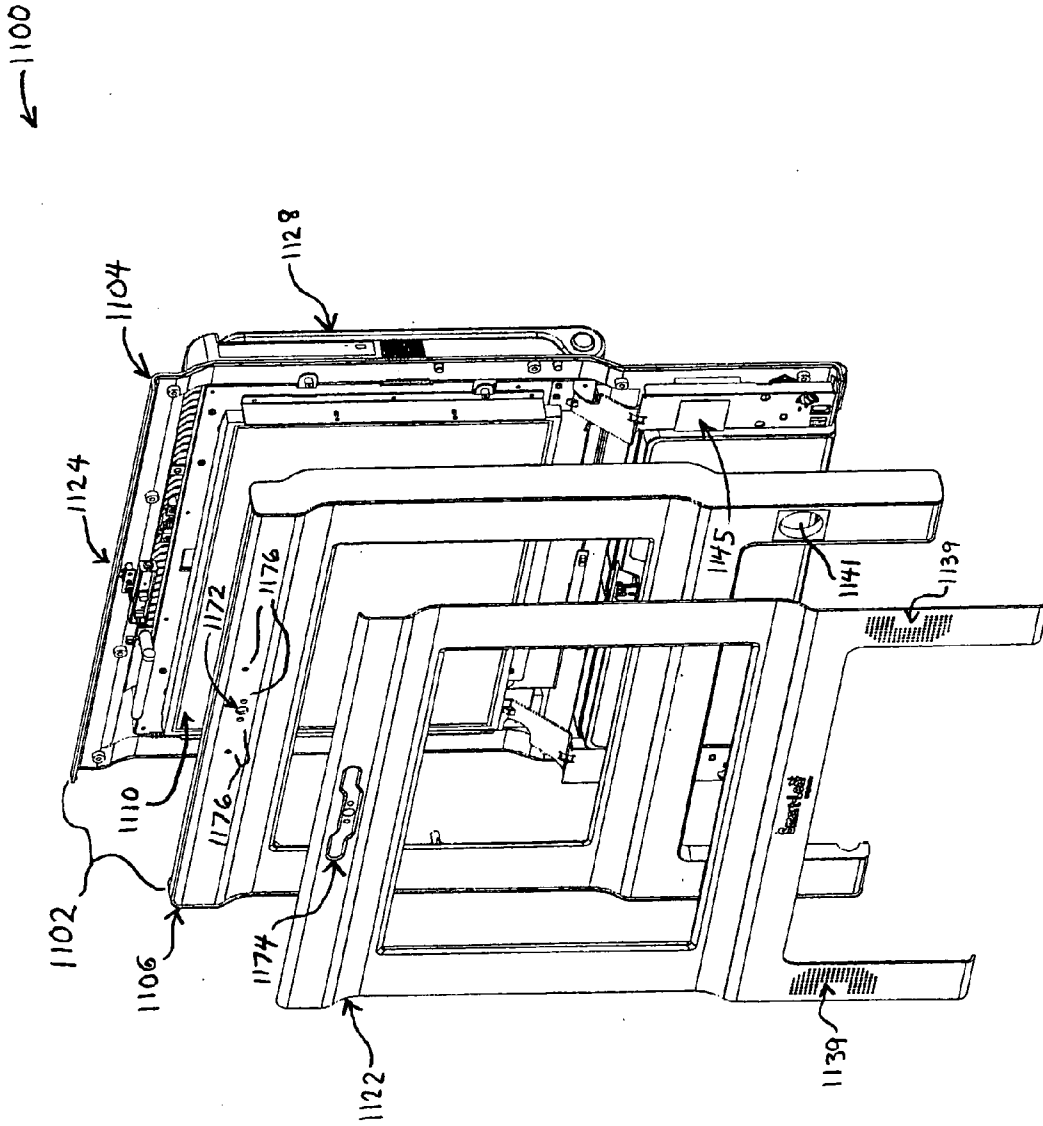

FIG. 89



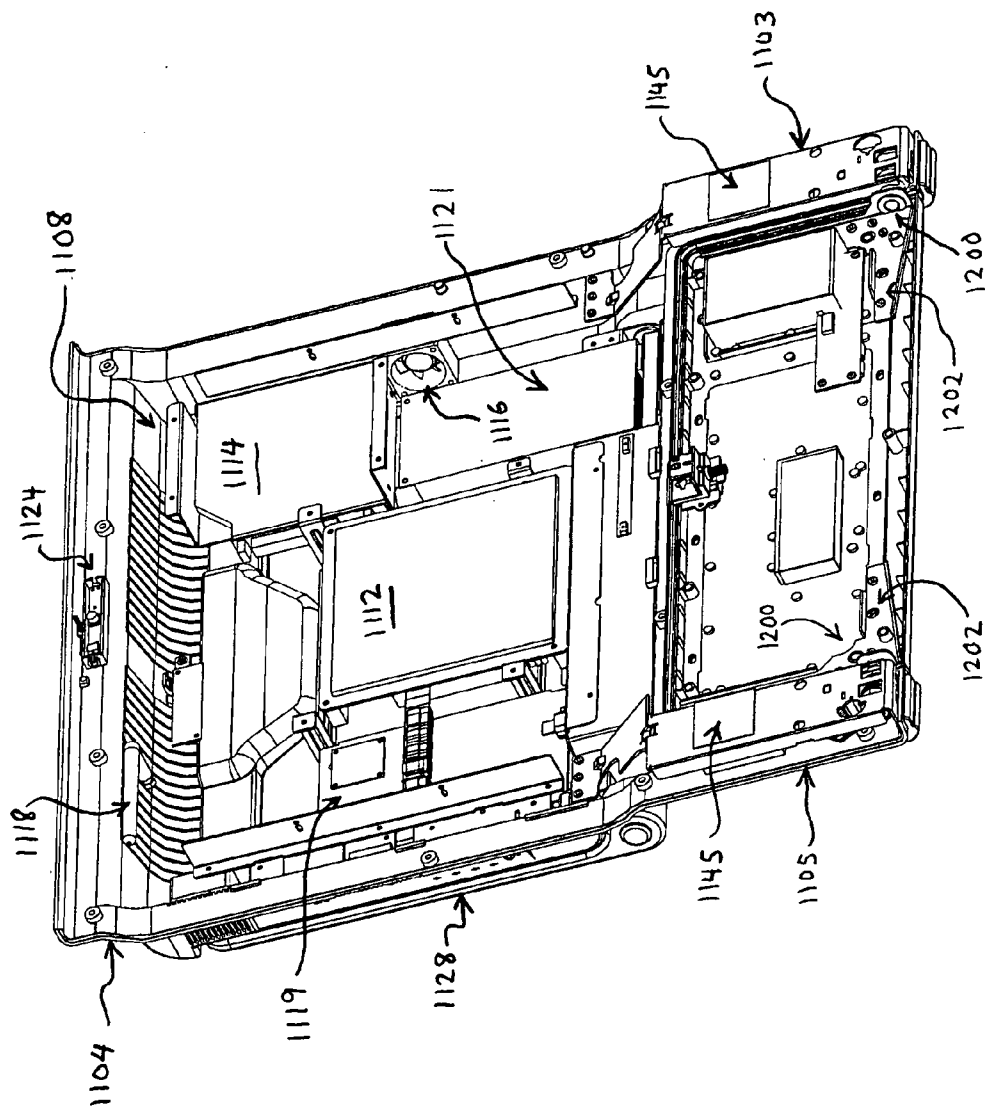

FIG. 90

FIG. 91

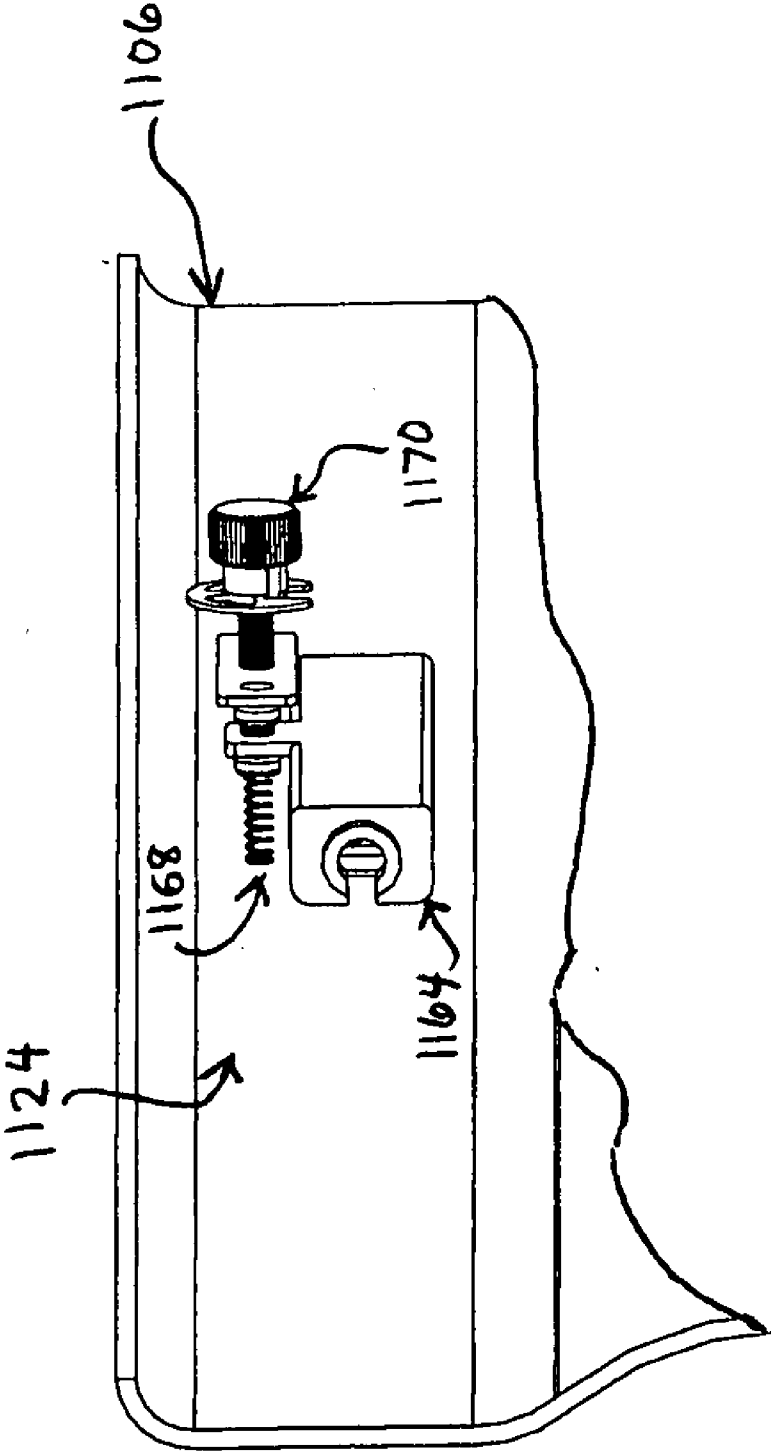
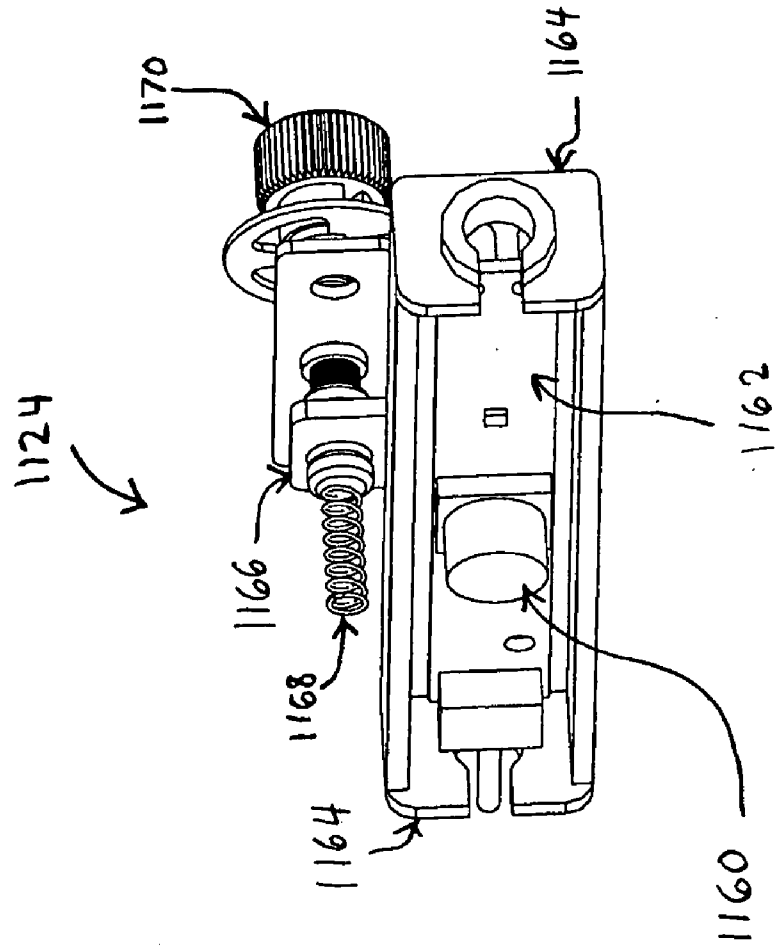

FIG. 92



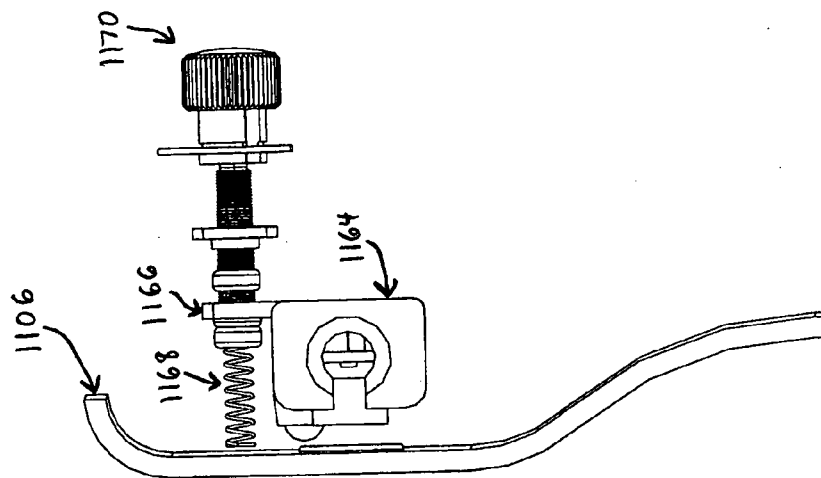

FIG. 93

FIG. 95

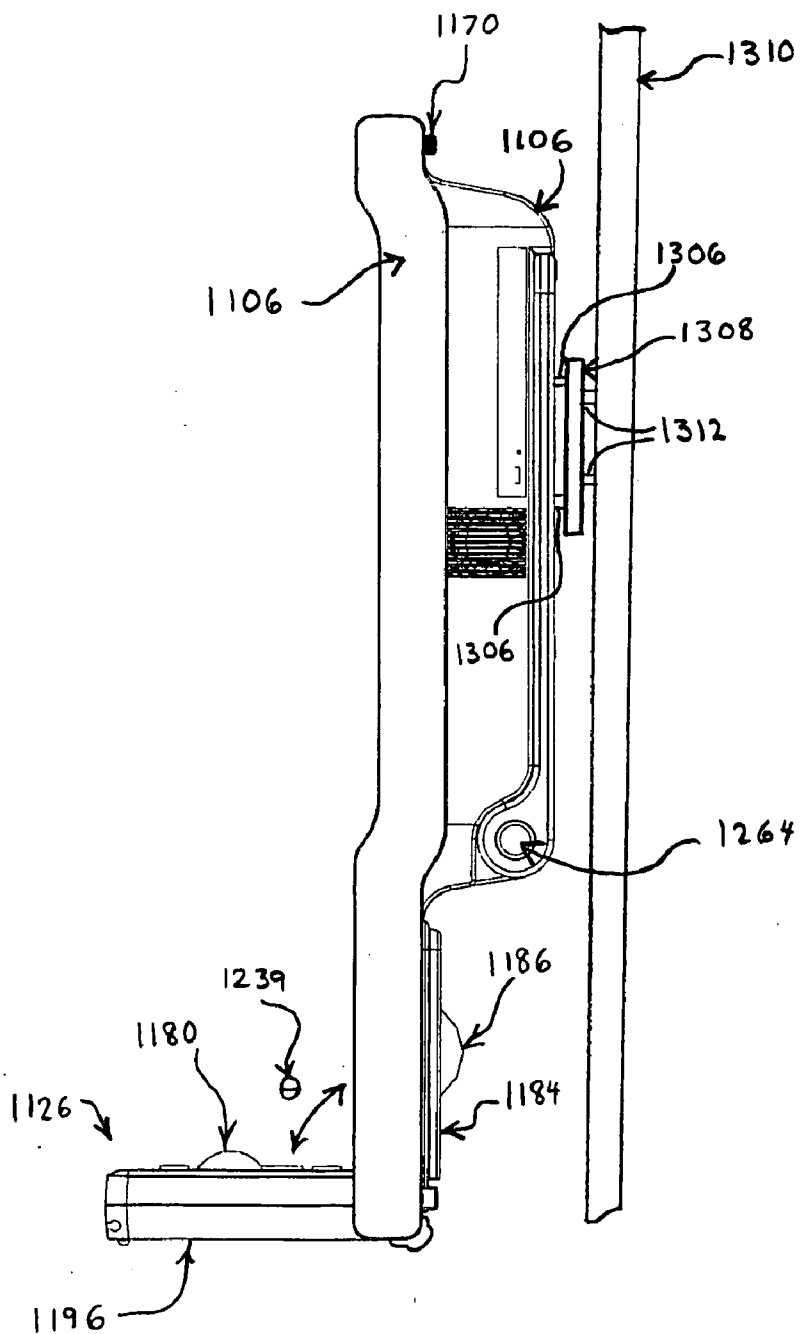

FIG 96

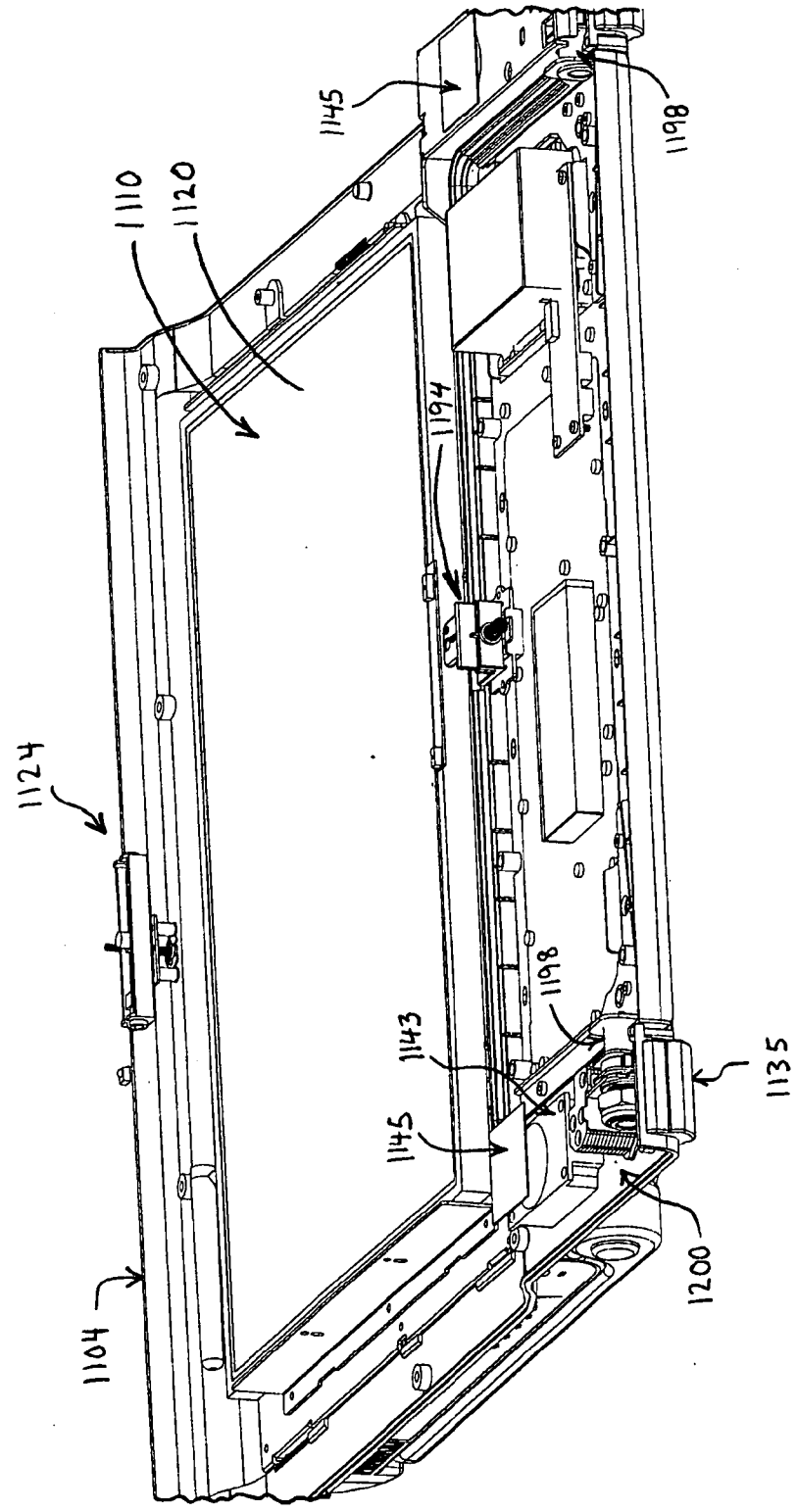

FIG. 97

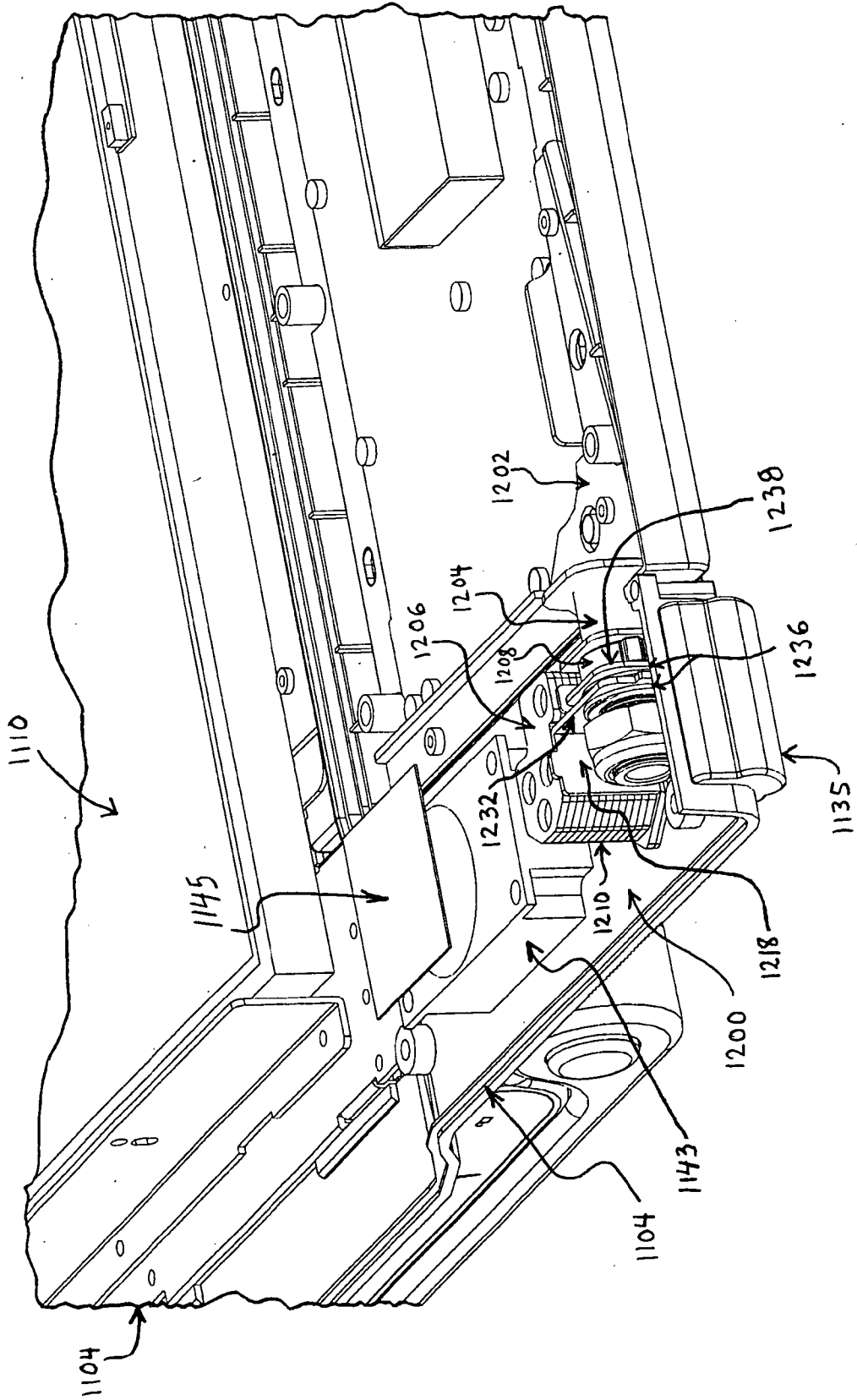

FIG. 98

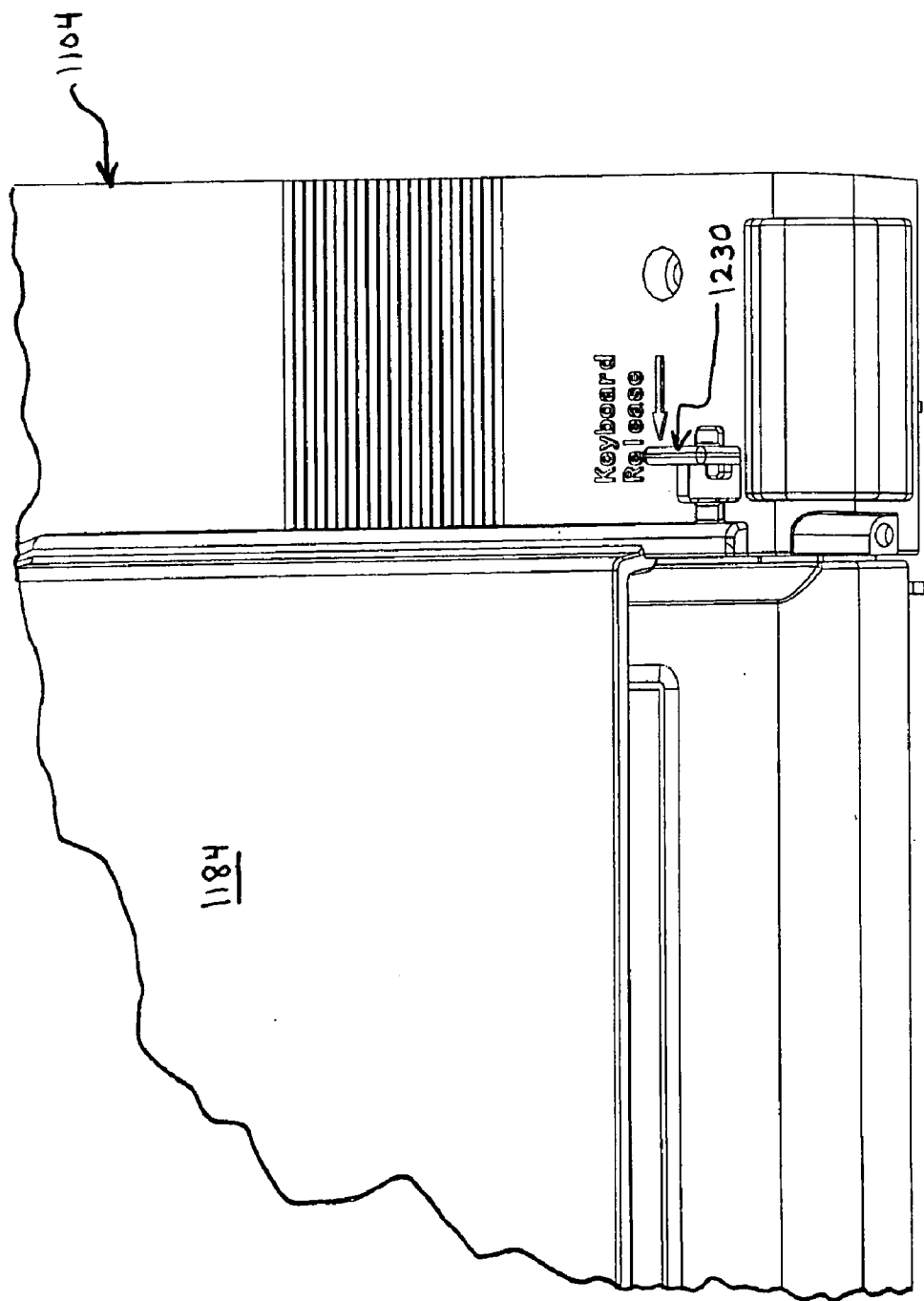

FIG. 99

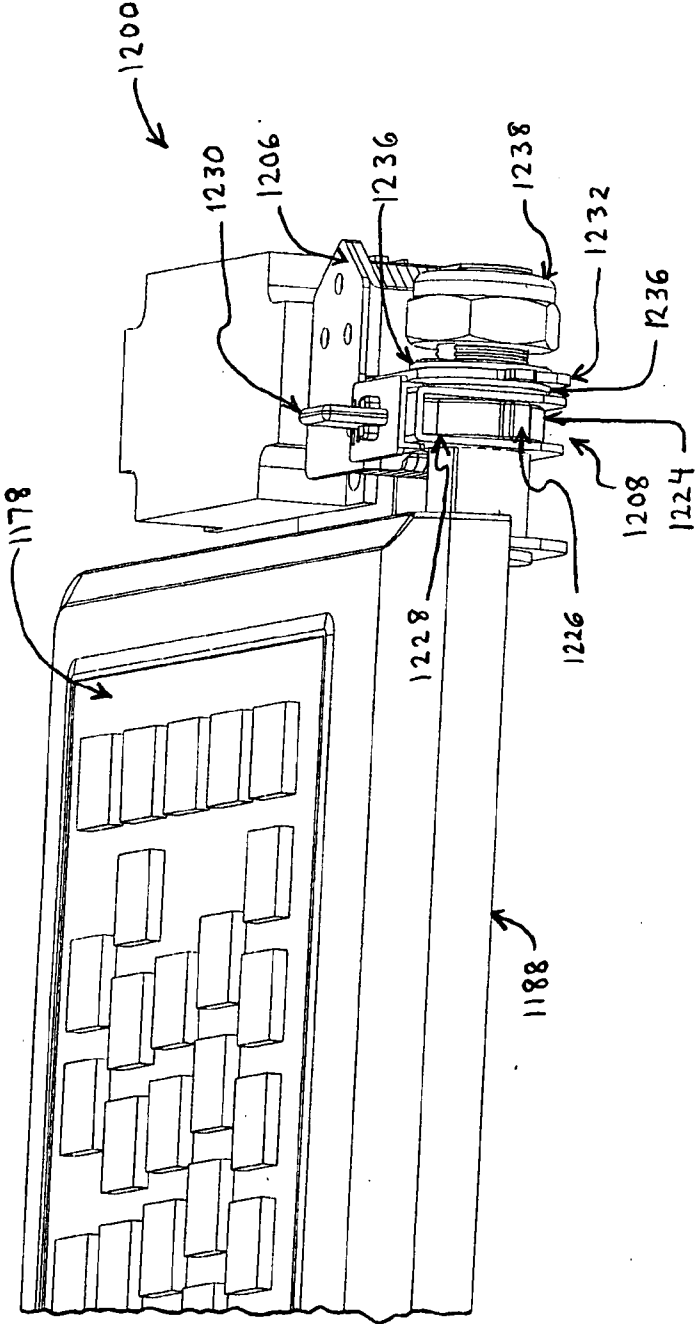

FIG. 100

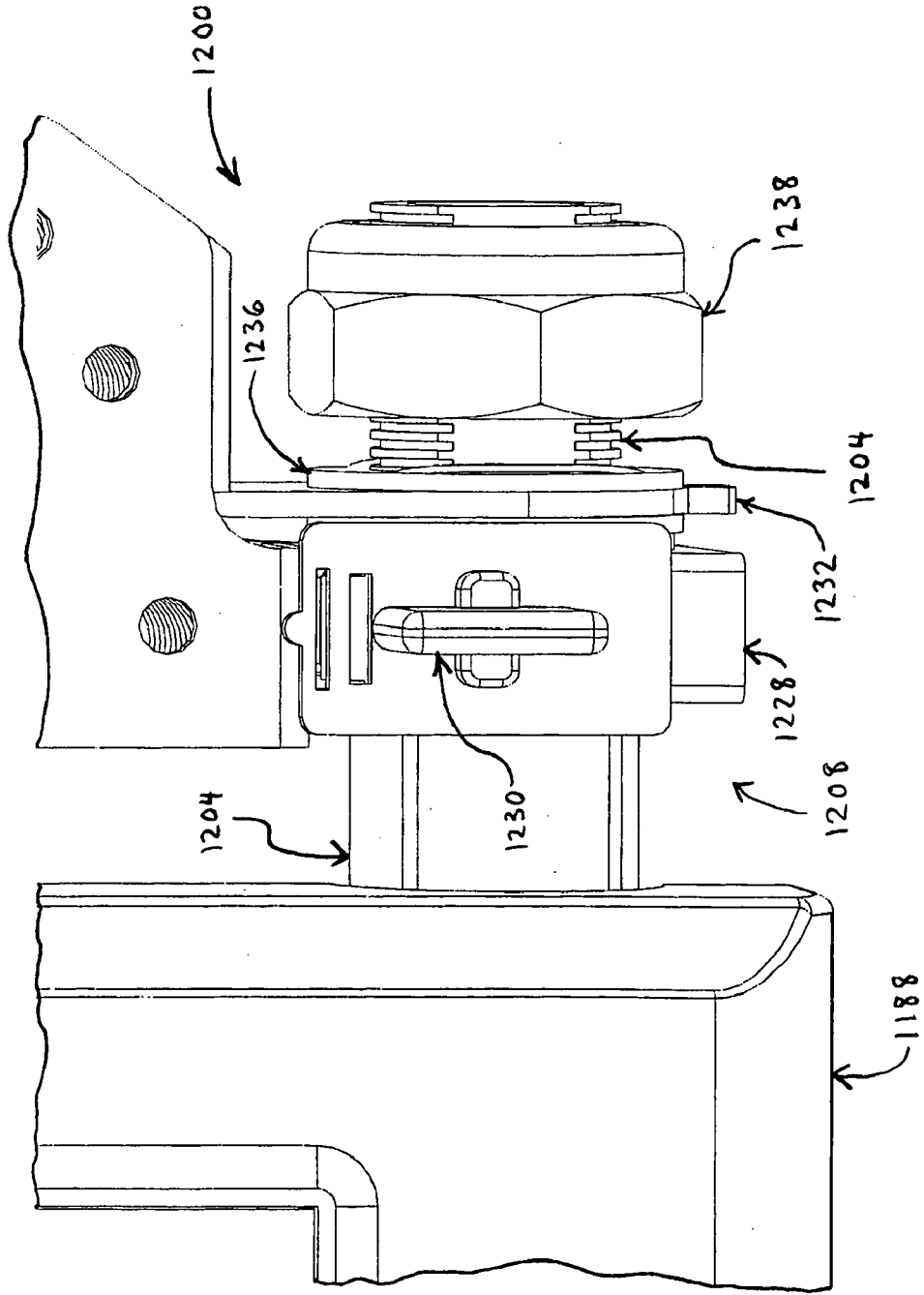

FIG. 101

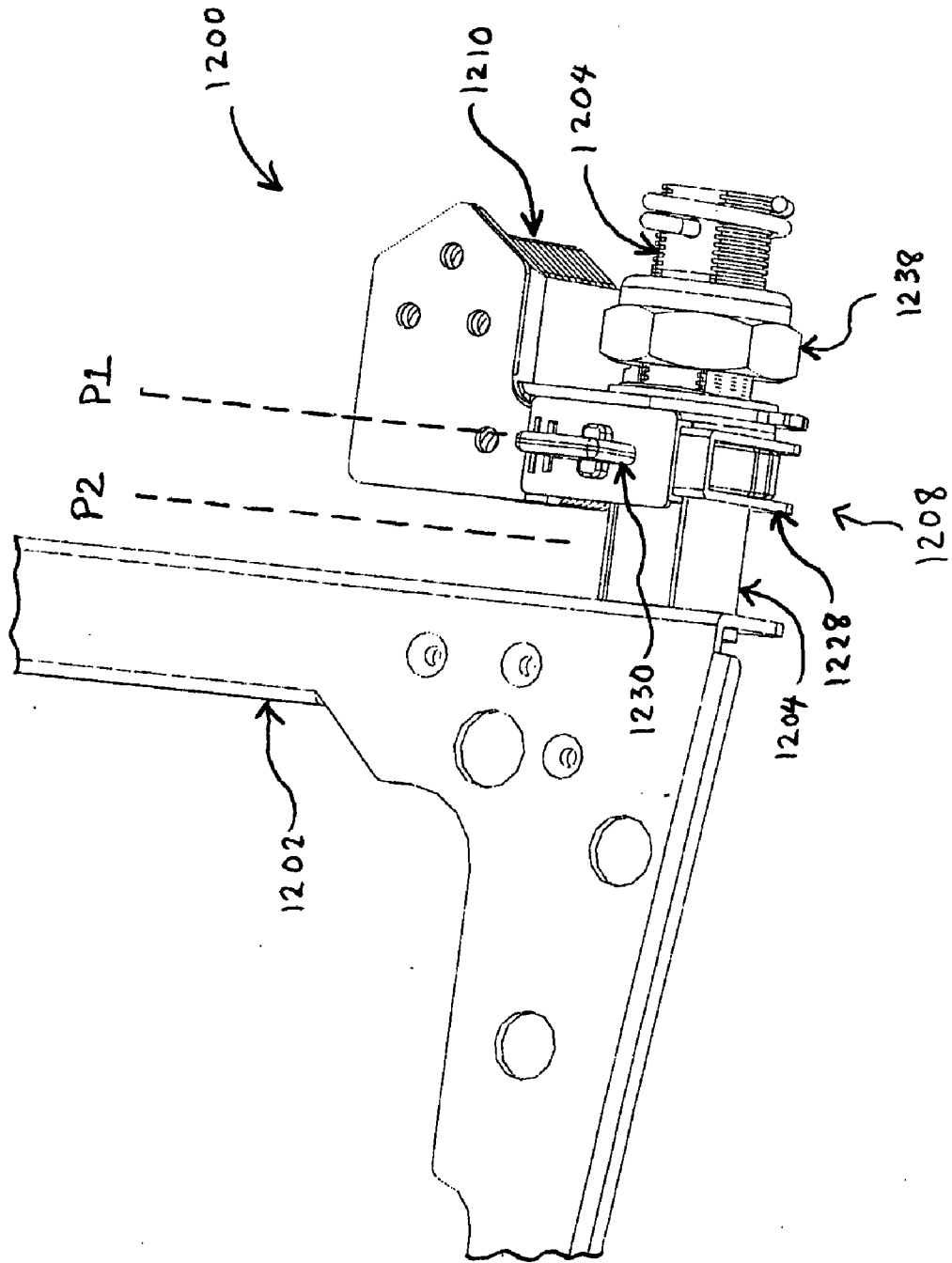

FIG. 102

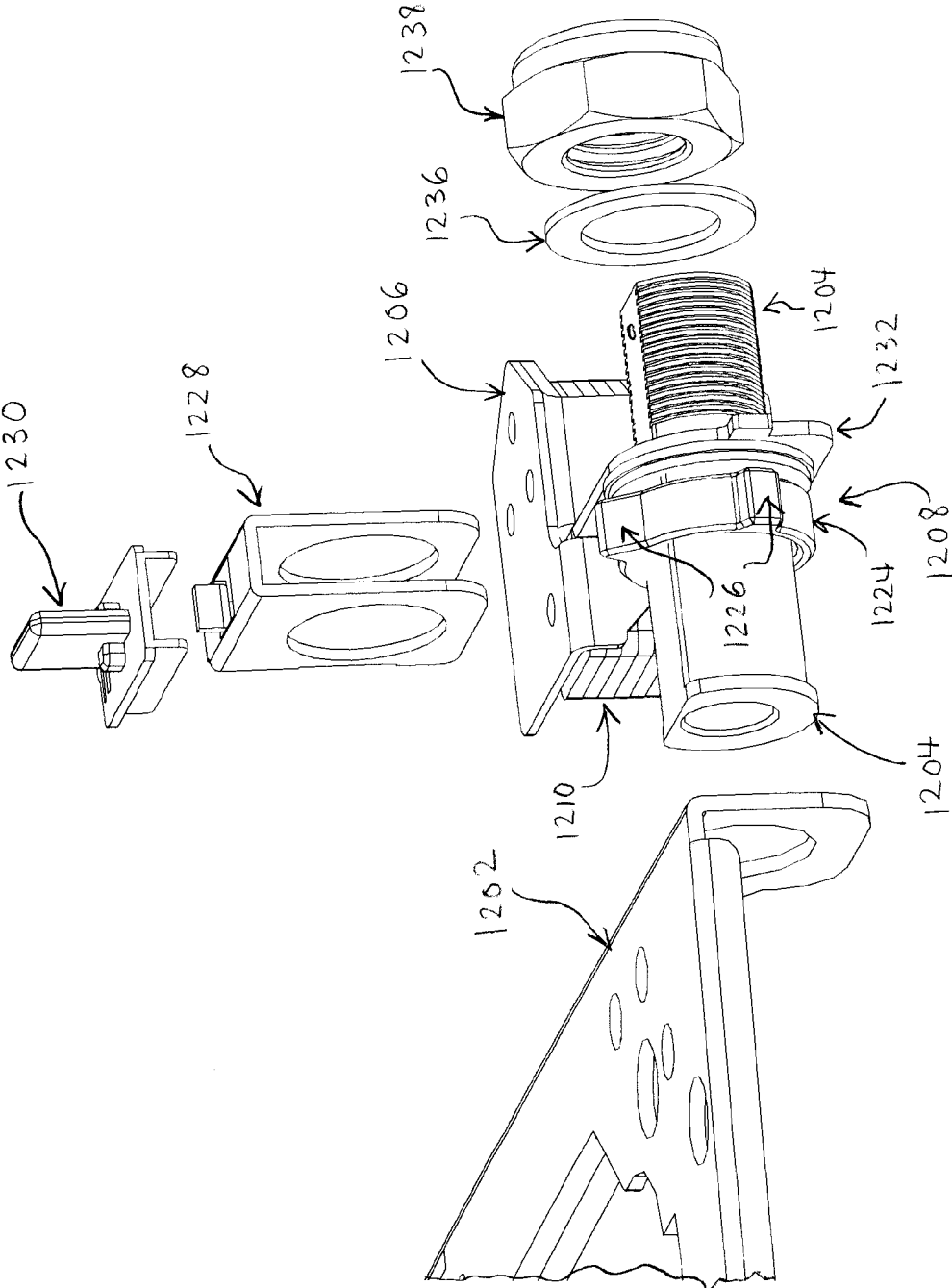

FIG. 103

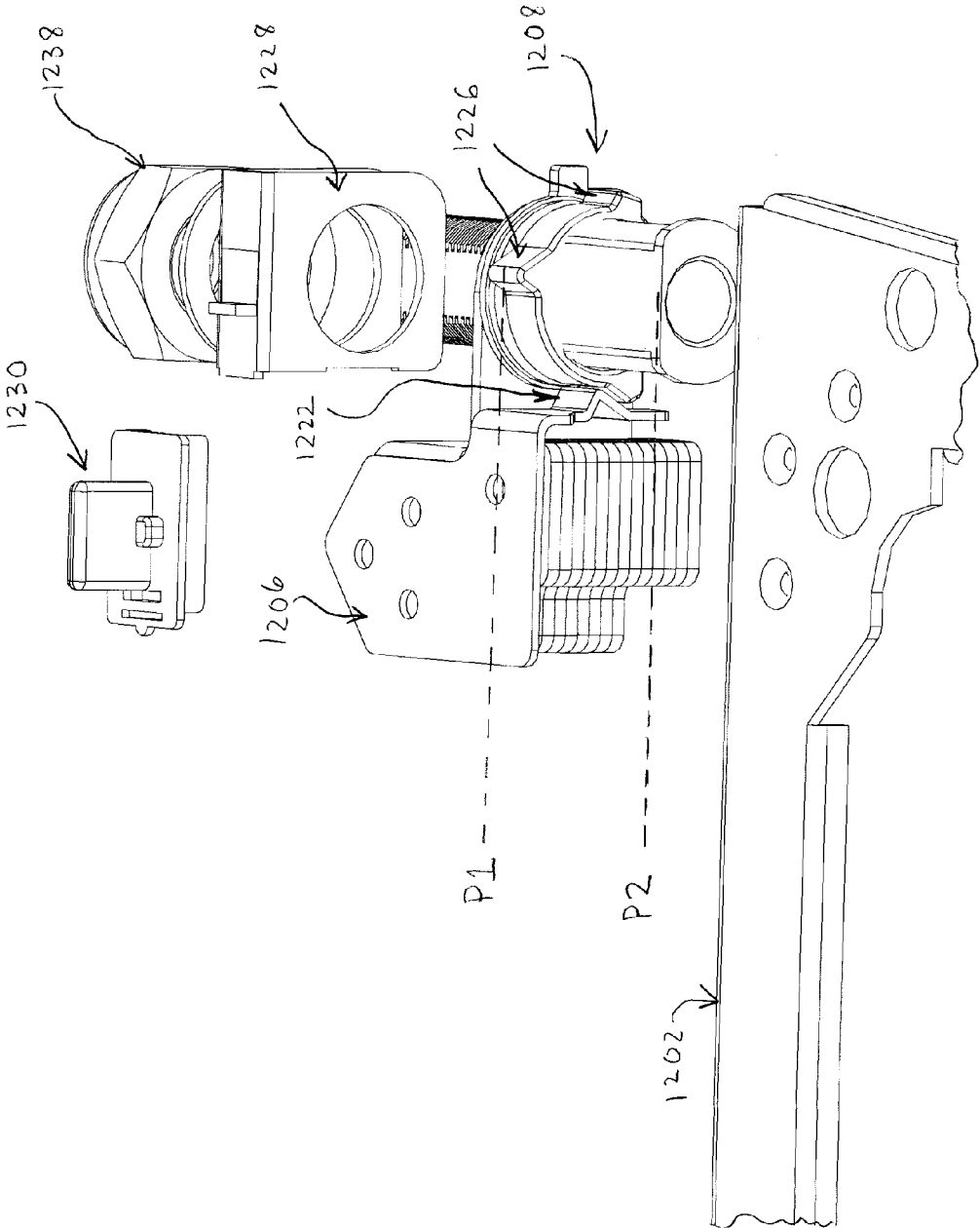

FIG. 104

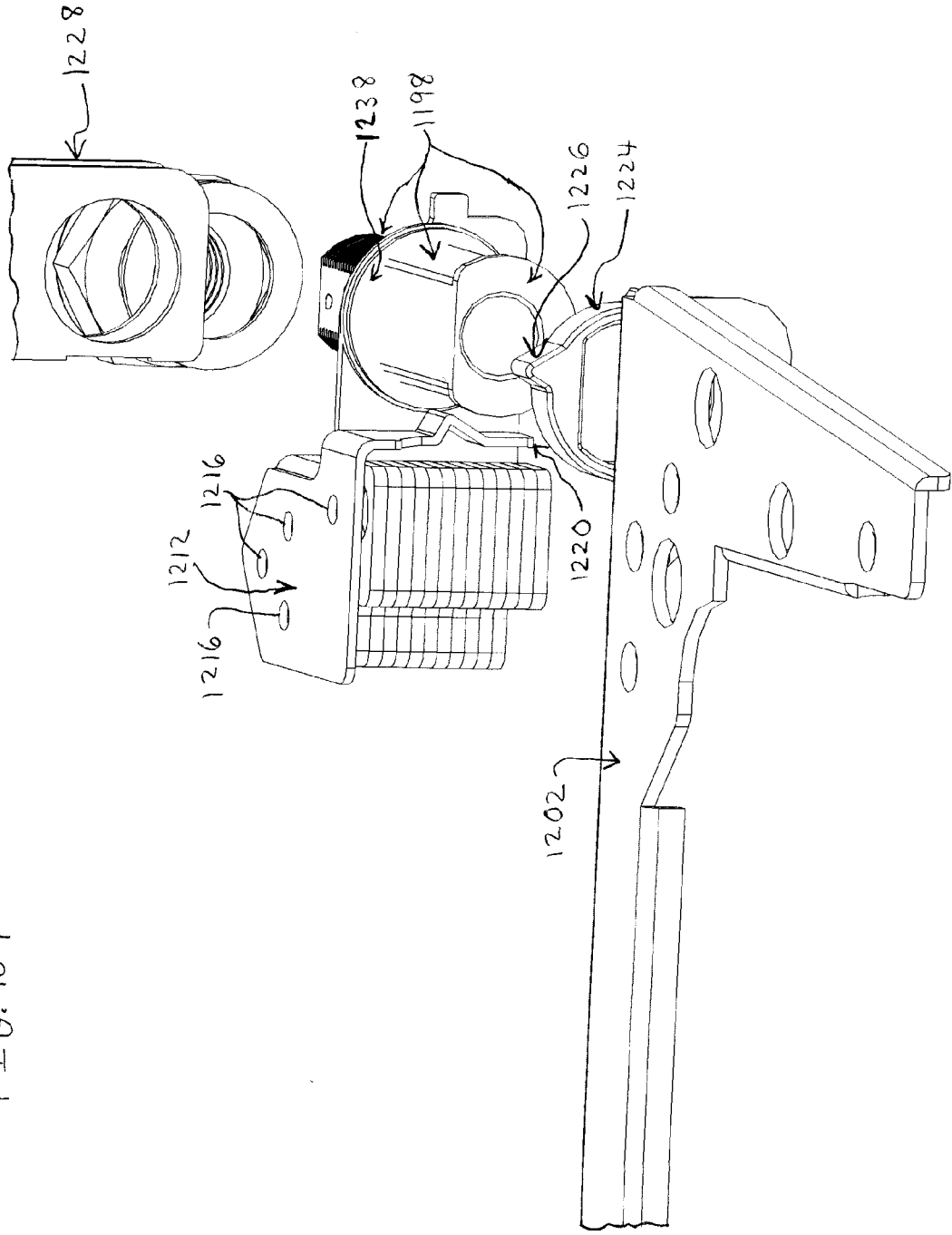

FIG. 105

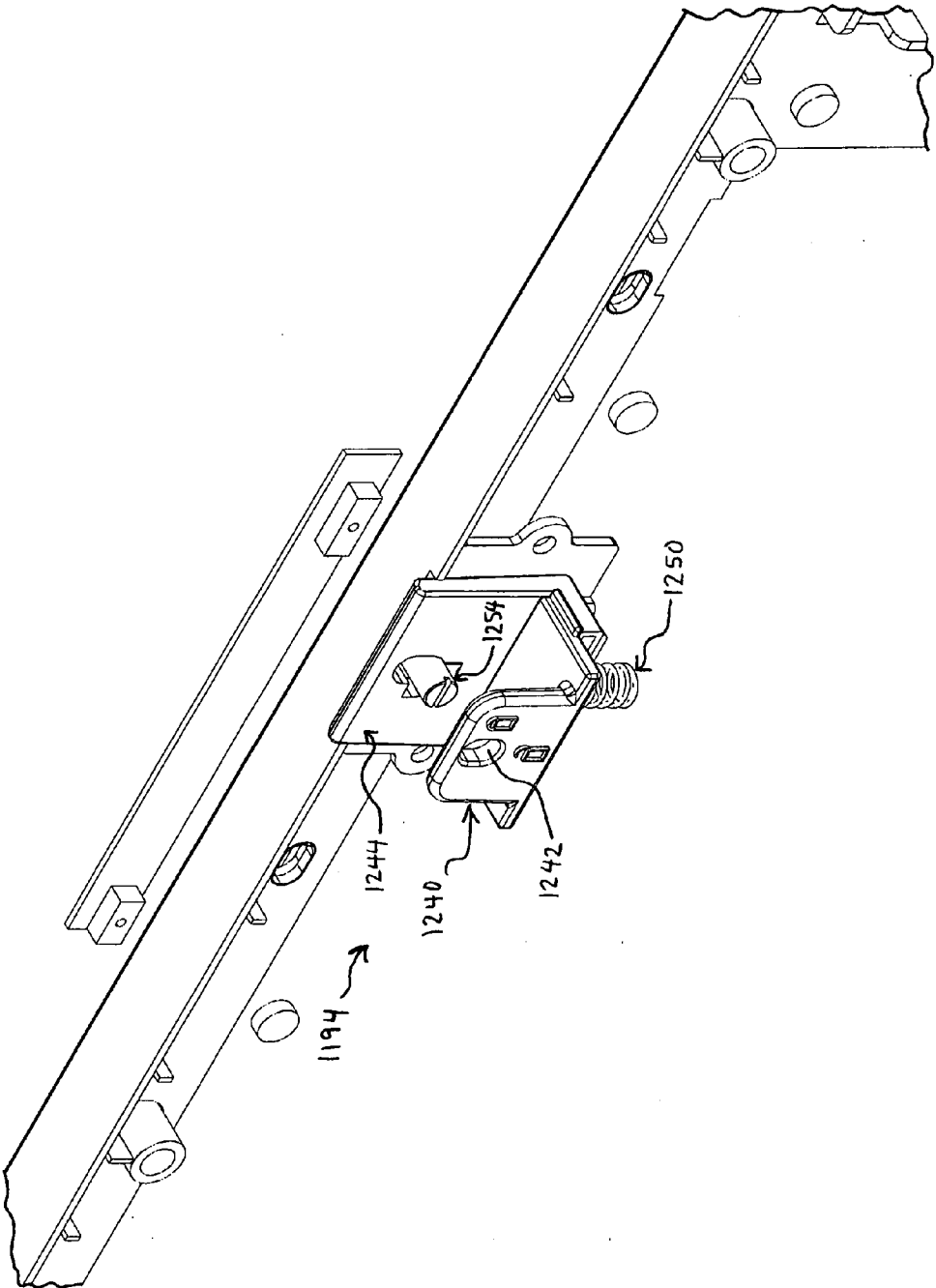

FIG. 106

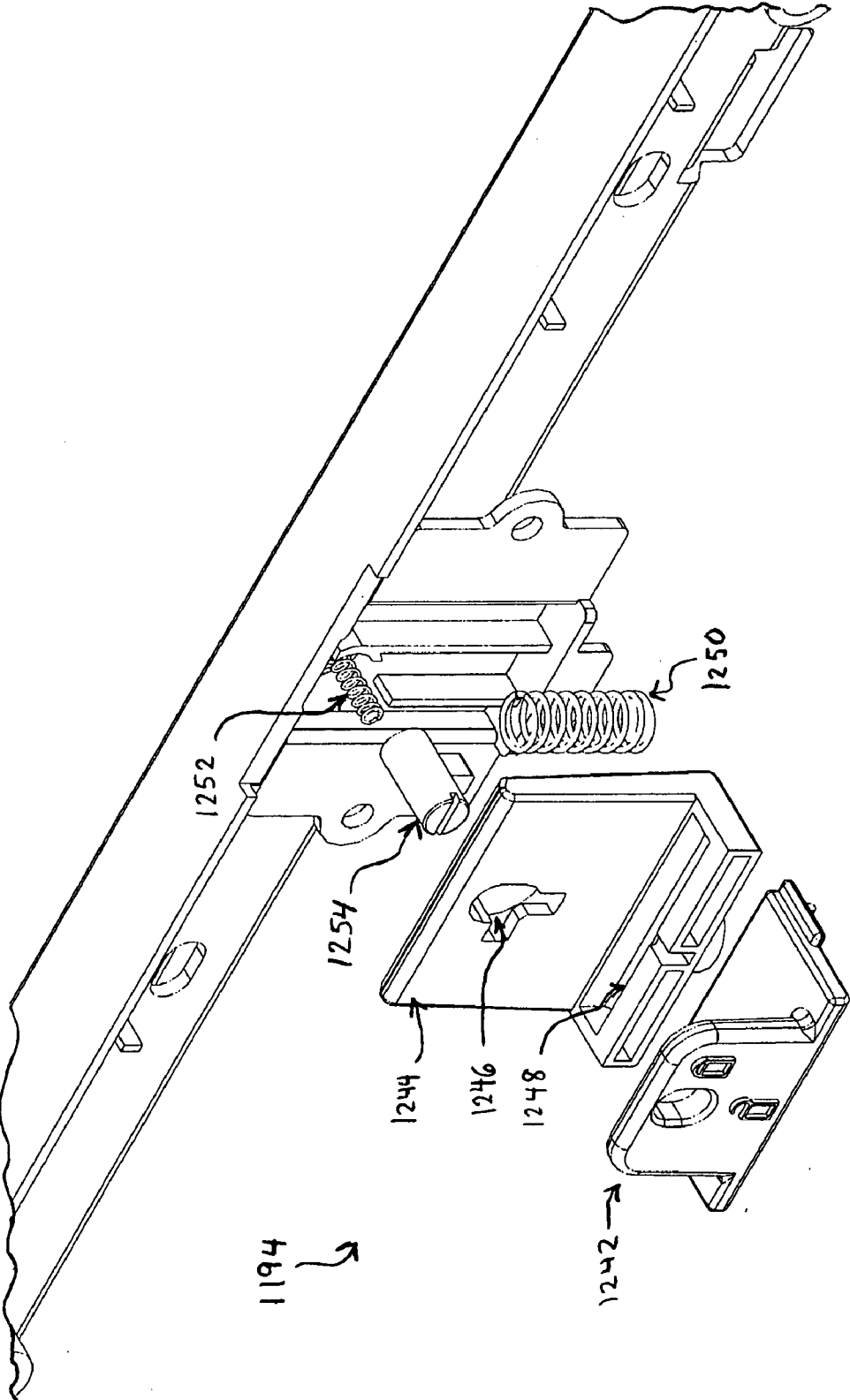
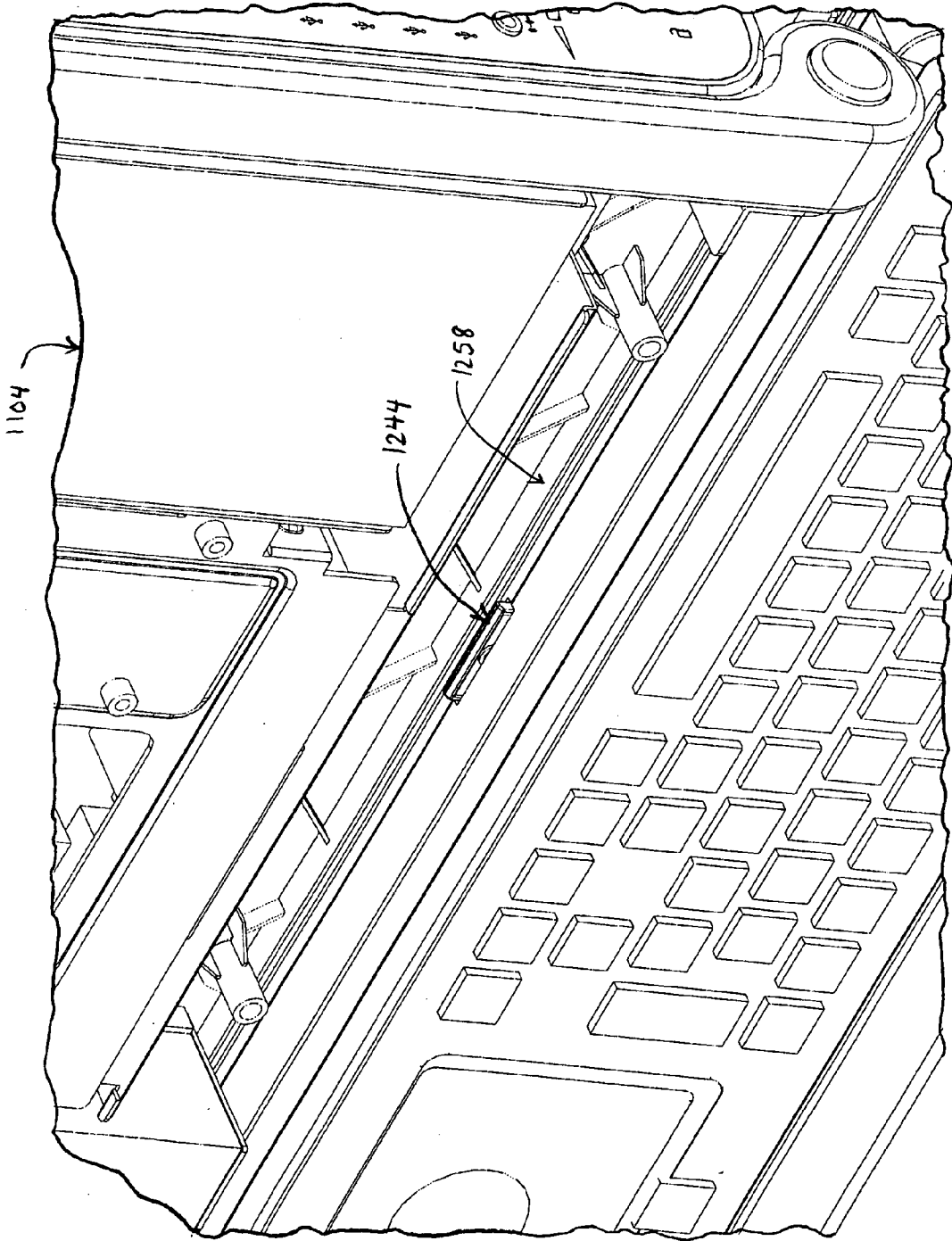

FIG. 107



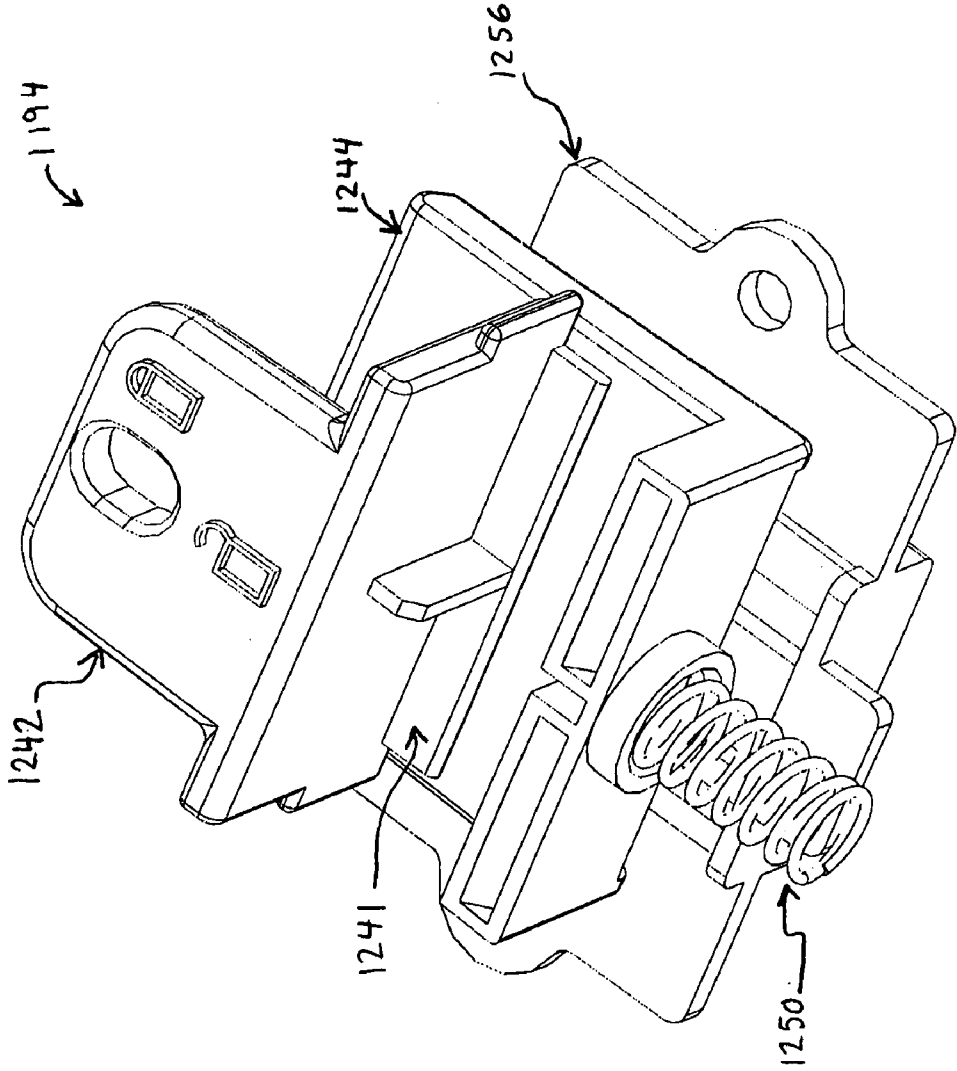

FIG. 108

FIG. 109

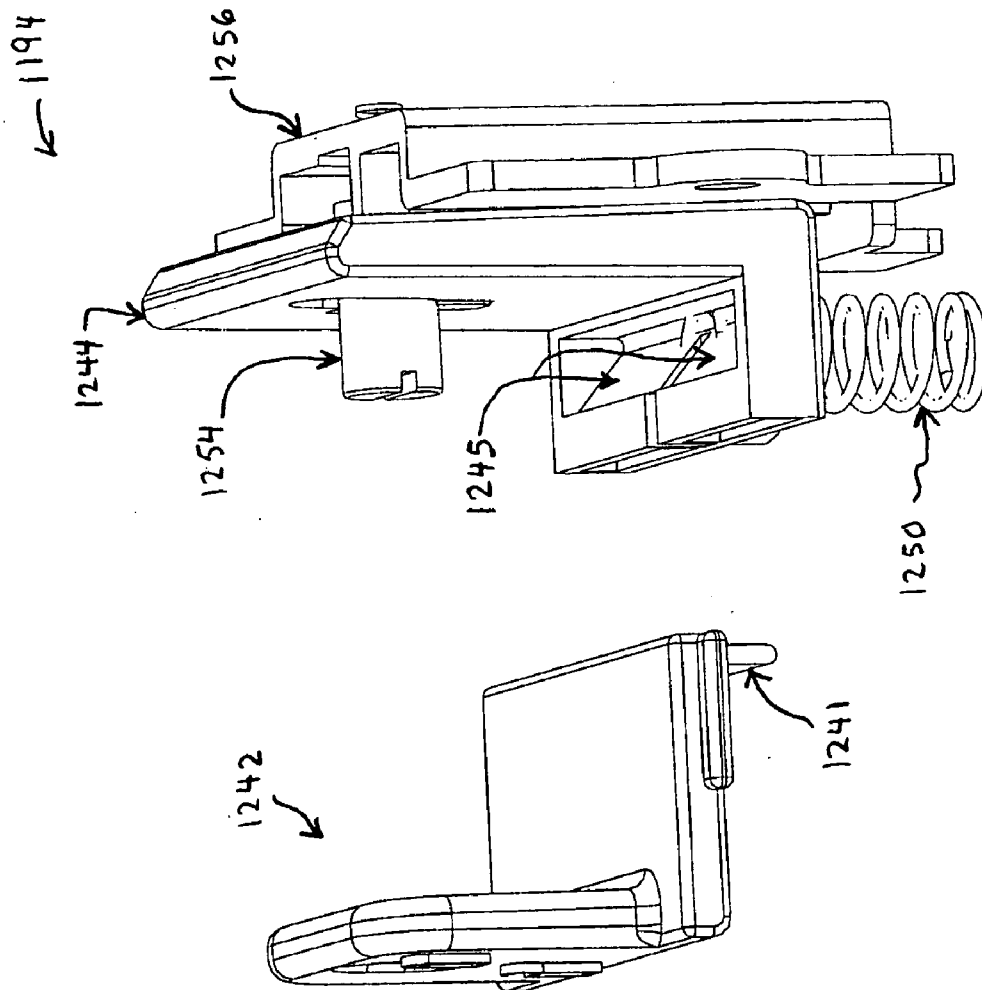

FIG. 110

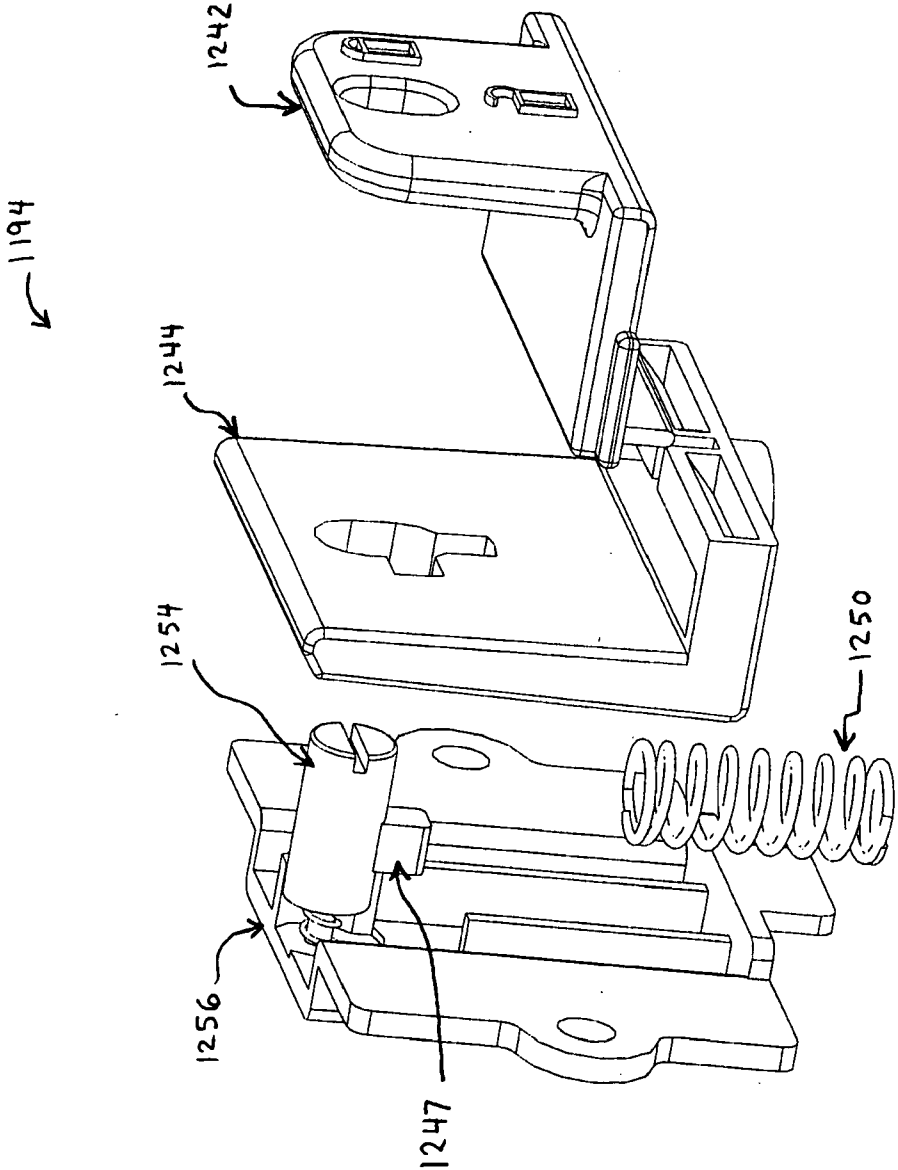
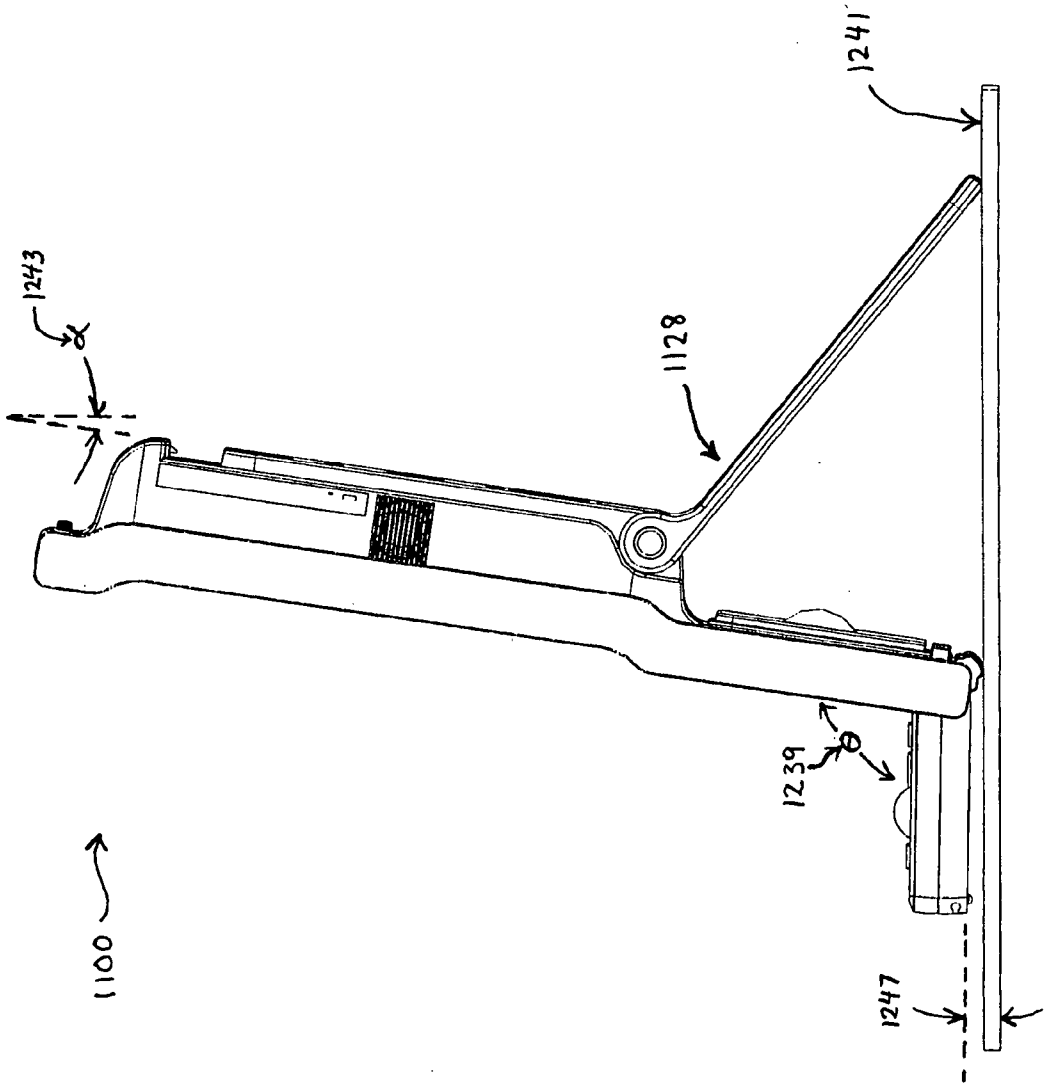

FIG. 111



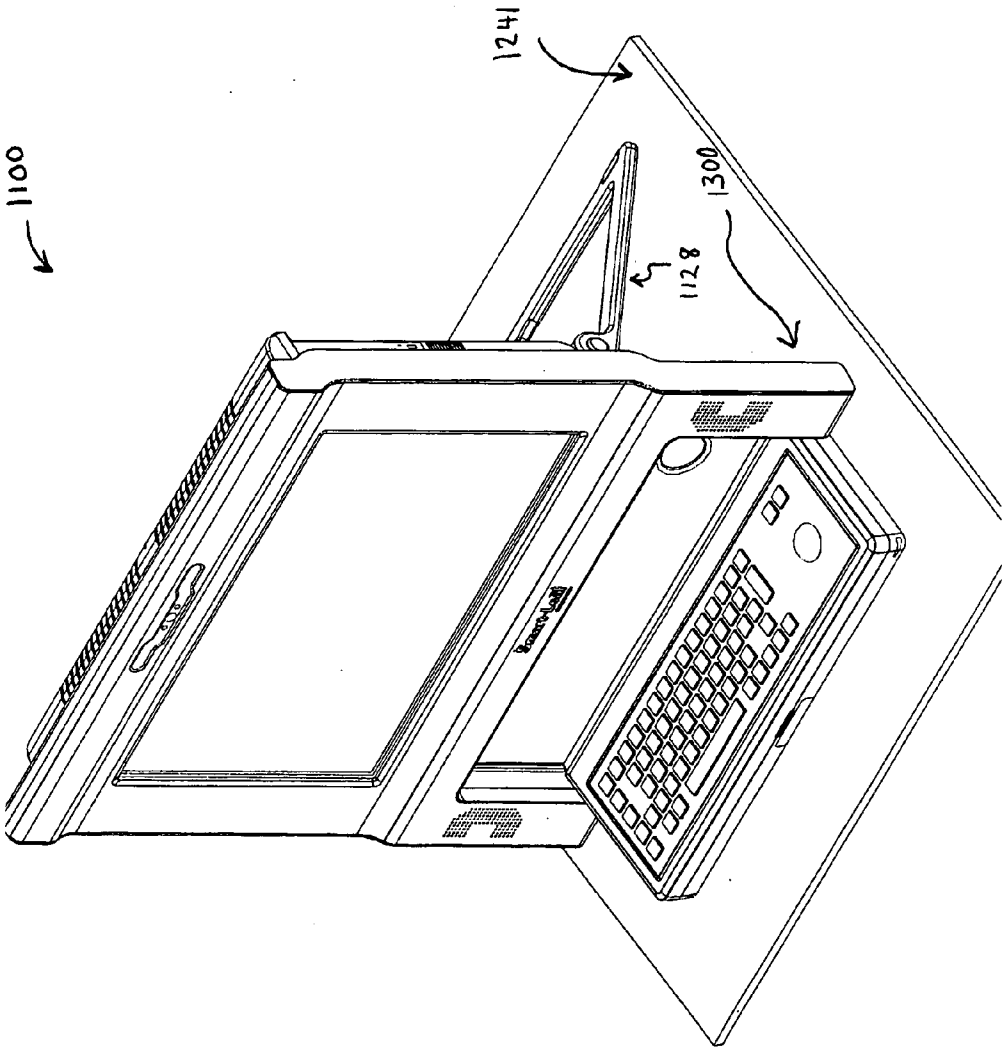

FIG. 112

FIG. 113

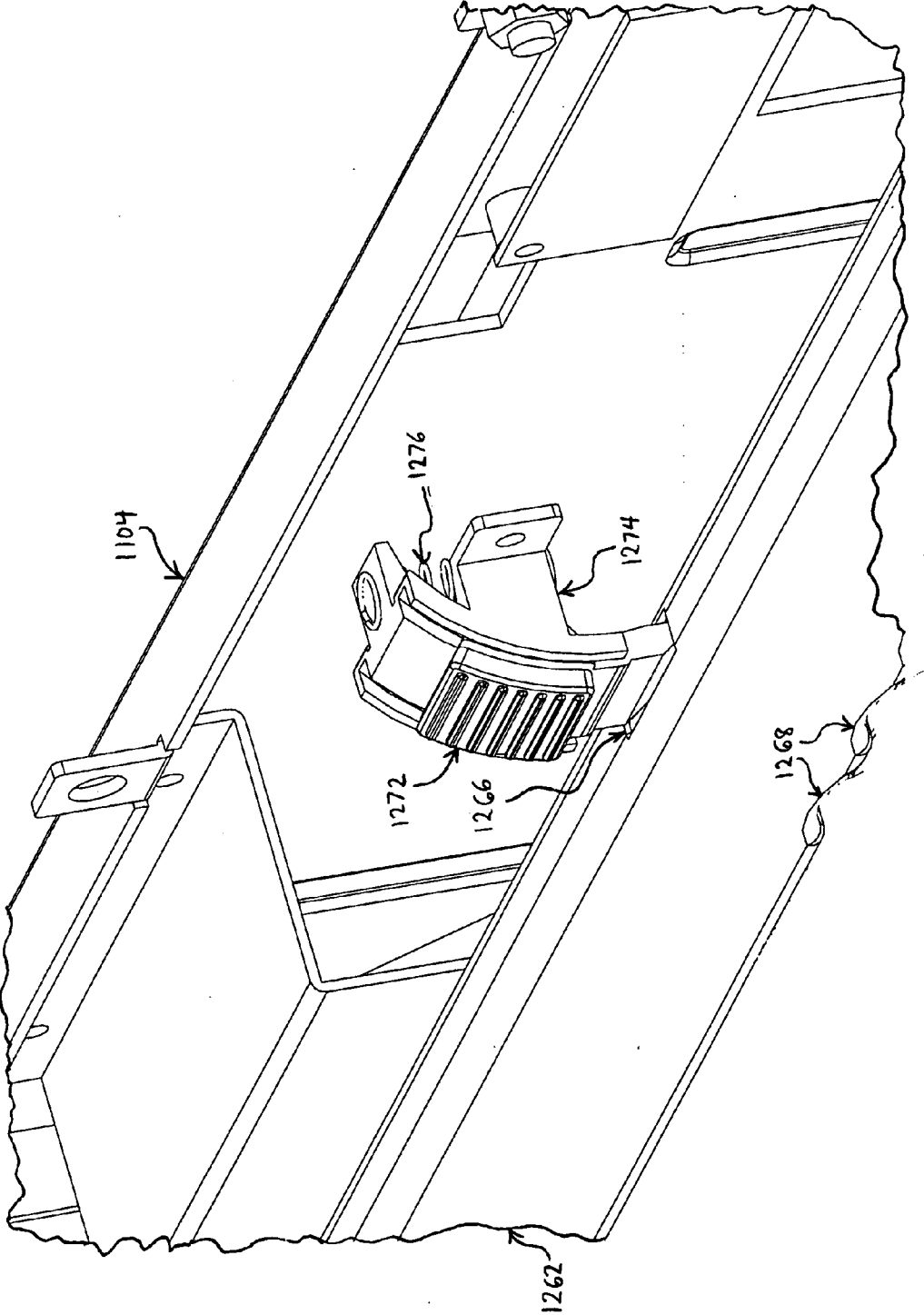

FIG. 114

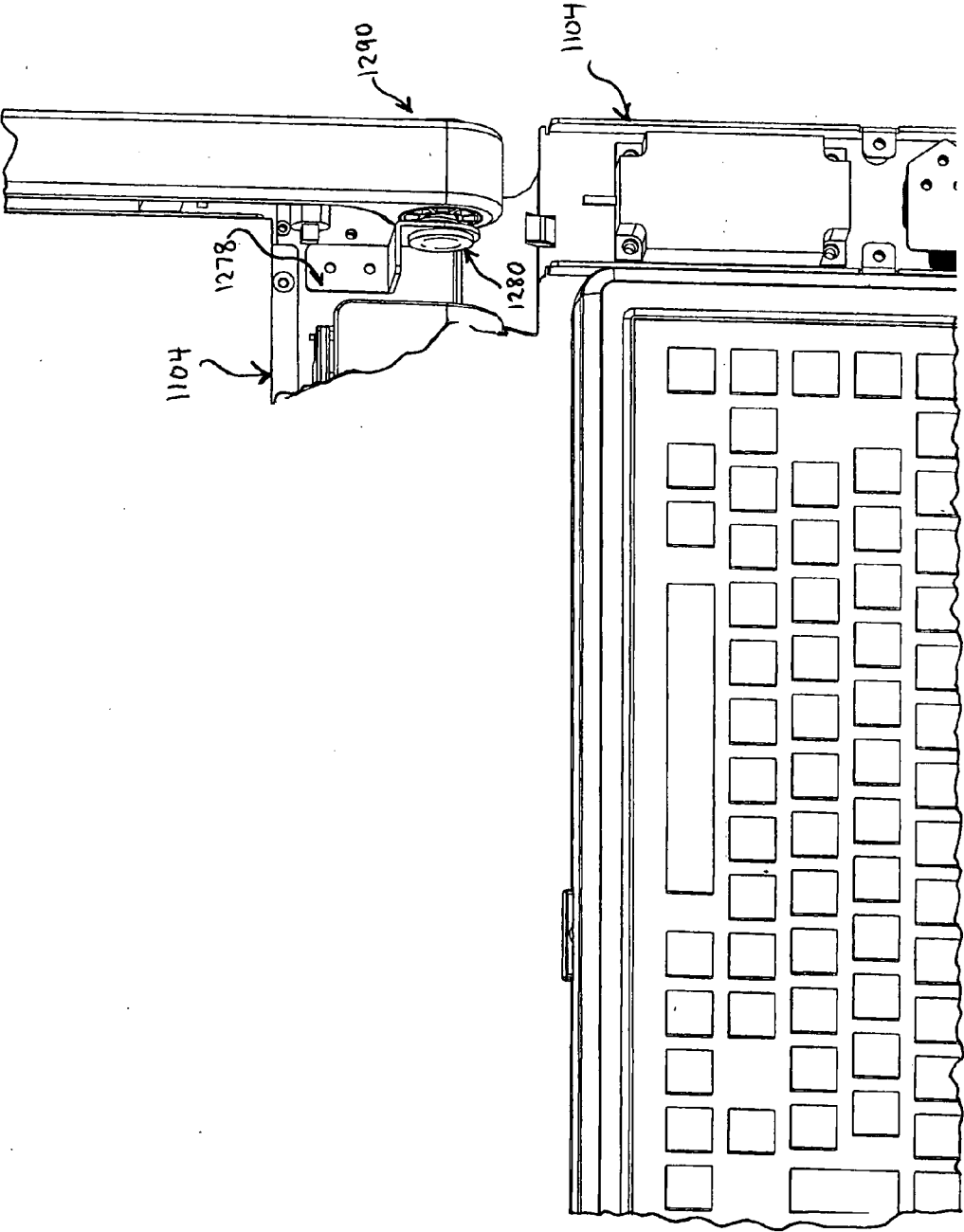

FIG. 115

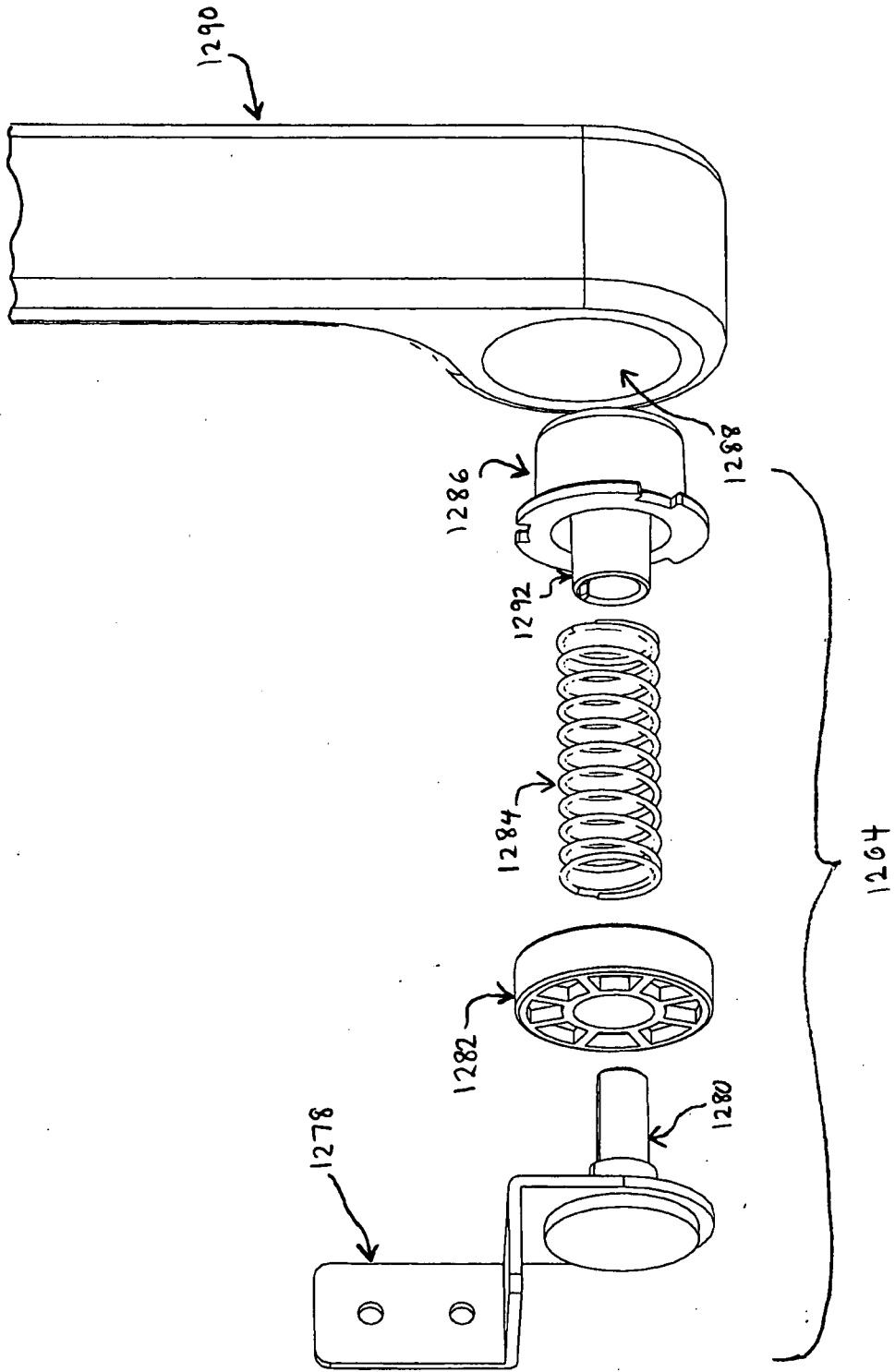
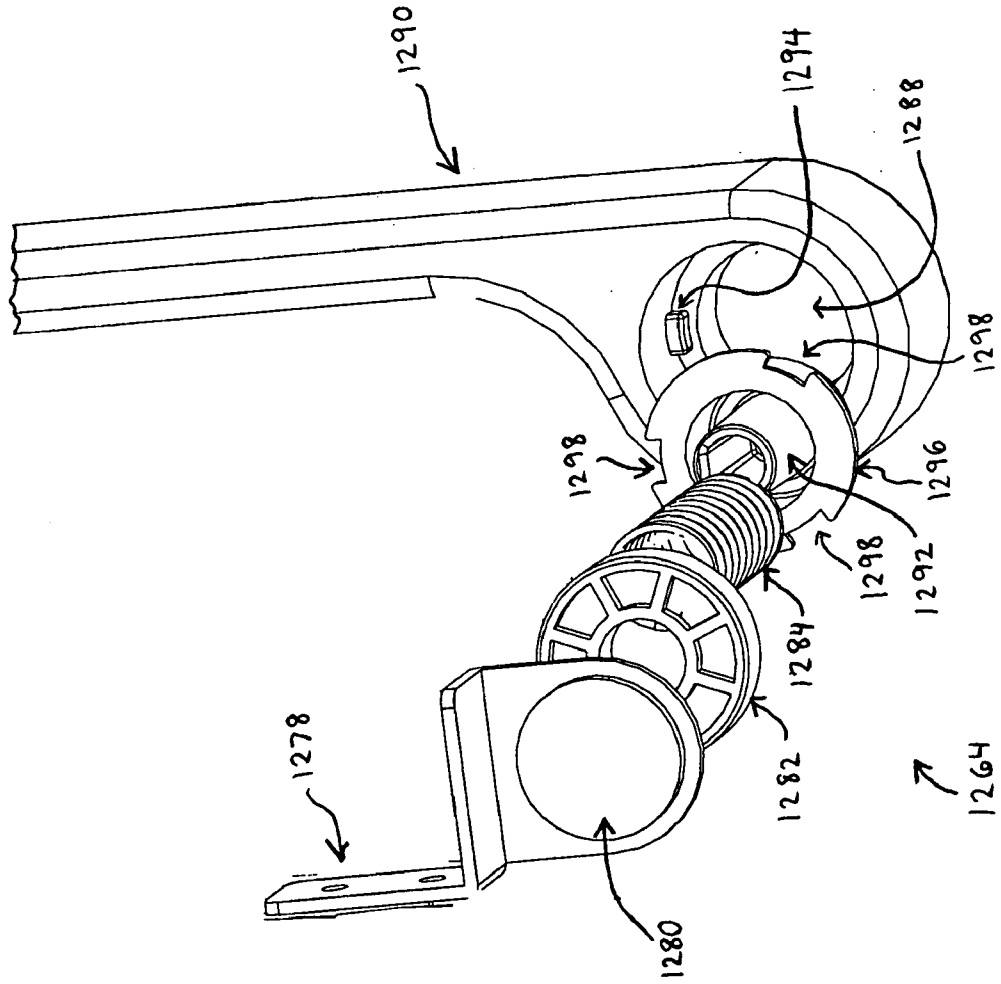

FIG. 116



ELECTRONIC DEVICE

PRIORITY CLAIM

[0001] This application is a continuation-in-part of, and claims the benefit and priority of, U.S. patent application Ser. No. 11/787,999, filed on Apr. 17, 2007, which is a continuation-in-part of, and claims the benefit and priority of, U.S. patent application Ser. No. 11/315,830, filed on Dec. 22, 2005, which, in turn, is a continuation-in-part of, and claims the benefit and priority of, U.S. patent application Ser. No. 10/795,684, filed on Mar. 8, 2004, now U.S. Pat. No. 7,158,373, and the entire contents of such applications are hereby incorporated by reference.

CROSS REFERENCE TO RELATED APPLICATION

[0002] This application is related to the following commonly-owned co-pending patent application: U.S. patent application Ser. No. 11/509,392, filed on Aug. 24, 2006.

COPYRIGHT NOTICE

[0003] A portion of the disclosure of this patent document contains or may contain material which is subject to copyright protection. The copyright owner has no objection to the photocopy reproduction by anyone of the patent document or the patent disclosure in exactly the form it appears in the Patent and Trademark Office patent file or records, but otherwise reserves all copyright rights whatsoever.

BACKGROUND

[0004] There is a growing need and demand for access to devices which provide electronic information or enable electronic-based transactions. As a result, there is a need to increase the accessibility, operational convenience, number of functions and space efficiency of such devices.

SUMMARY

[0005] In one embodiment, the electronic device includes: (a) a main housing defining a cavity; (b) a display screen supported by the main housing; (c) a motherboard positioned within the cavity behind the display screen; and (d) a keyboard assembly supported by the main housing.

[0006] The keyboard assembly has: (a) a keyboard housing having a plurality of ends; (b) a plurality of shafts, each one of the shafts coupled to one of the ends; and (c) at least one keyboard position controller.

[0007] The keyboard position controller has: (a) a spring device coupled to the main housing, the spring device having a contact portion; and (b) a spring device engager coupled to the at least one shaft. The spring device engager is configured to be: (i) engaged with the contact portion when the keyboard is subject to a first force; and (ii) disengaged from the contact portion when the keyboard is subject to a greater, second force.

[0008] In one embodiment, the electronic device has a camera assembly supported by the main housing. The camera assembly has: (a) a camera having a lens; (b) a lens holder which holds the lens of the camera, the lens holder being movably coupled to the main housing; and (c) a lens position controller which is adjustable to cause movement of the lens holder.

[0009] In one embodiment, the electronic device has a desktop stand assembly supported by the main housing. The desktop stand assembly has: (a) a stand having a foot portion; (b) at least one stand coupler unit which pivotably couples the stand to the main housing so that the stand is pivotable between: (i) an upward position in which the foot portion is adjacent to the upper rear side of the main housing; and (ii) a downward position in which the foot portion is engaged with a support surface.

[0010] In one embodiment, the at least one keyboard position controller has a resistance device configured to produce a resistance to a rotation of the at least one shaft.

[0011] In one embodiment, the resistance device includes: (a) a support coupled to the main housing, the support defining an opening which receives a portion of the at least one shaft; (b) an extension coupled to the at least one shaft; and (c) a fastener configured to apply a force to press the extension against the support.

[0012] In one embodiment, the spring device engager has a cam device coupled to the at least one shaft. The cam device has at least one protrusion which moves with a rotation of the at least one shaft. The protrusion is movable between: (a) a first position in which the protrusion is engaged with the contact portion; and (b) a second position in which the protrusion has moved past the contact portion and is disengaged from the contact portion.

[0013] In one embodiment, the spring device engager: (a) has a first angular position when the keyboard is subject to the first force; (b) has a second angular position when the keyboard is subject to the second force; and (c) is configured to be moved relative to the at least one shaft between: (i) a first adjustable position associated with a keyboard set mode, wherein the spring device engager is positioned to be brought into engagement with the contact portion when the spring device engager has the first angular position; and (ii) a second adjustable position associated with a keyboard release mode, wherein the spring device engager is positioned to be disengaged from the contact portion when the spring device engager has the first angular position.

[0014] In one embodiment, the electronic device includes a grasp coupled to the spring device engager. The grasp extends through an opening defined by the main housing, and the grasp is movable between: (i) a first grasp position associated with the keyboard set mode; and (b) a second grasp position associated with the keyboard release mode.

[0015] In one embodiment, the main housing defines a latch space, and the keyboard assembly has a keyboard latch. The keyboard latch includes: (i) a latch grasp; (ii) a latch spring coupled to the latch grasp; and (iii) a male member configured to be movable into and out of the latch space.

[0016] In one embodiment, the keyboard latch has a latch set device which is operable to set the keyboard latch in a closed mode, wherein the male member is positioned within the latch space when the keyboard latch has the closed mode.

[0017] In one embodiment, the lens holder is pivotably coupled to the main housing.

[0018] In one embodiment, the camera assembly has a spring coupled to the lens holder.

[0019] In one embodiment, a portion of the lens position controller is a camera adjustment grasp.

[0020] In one embodiment, the main housing has a rear side. The rear side defines a camera adjustment grasp opening configured to receive the camera adjustment grasp.

[0021] In one embodiment, the desktop stand assembly has a stand latch coupled to the main housing. The stand latch is configured to secure the stand in the upward position.

[0022] In one embodiment, the stand has a coupling wall, and the coupling wall defines: (i) an opening; and (ii) a protrusion.

[0023] In one embodiment, the stand coupler unit has a position setter coupled to the main housing. The position setter has a protrusion engager, and the position setter is movable between: (a) a first position in which the protrusion engager is engaged with the protrusion; and (b) a second position in which the protrusion engager is disengaged from the protrusion.

[0024] In one embodiment, the stand coupler unit has a housing coupler which is coupled to the housing. In one embodiment, the position setter has a stand coupler configured to mate with the housing coupler so that the housing coupler has a fixed angular position relative to the stand coupler.

[0025] In one embodiment, the stand coupler unit has a spring configured to bias the position setter to have the first position.

[0026] In one embodiment, the foot portion defines an opening, and the stand latch has a protrusion and a spring configured to bias the protrusion to project into the opening.

[0027] Additional features and advantages of the present invention are described in, and will be apparent from, the following Detailed Description of the Invention and the figures.

BRIEF DESCRIPTION OF THE FIGURES

[0028] FIG. 1 is a front elevation view of the hangeable or mountable electronic device hung on a wall in one embodiment.

[0029] FIG. 2 is a front perspective view of the hangeable or mountable electronic device of FIG. 1.

[0030] FIG. 3 is a front elevation view of the hangeable or mountable electronic device of FIG. 1, illustrating the data entry side of the input assembly.

[0031] FIG. 4 is a front elevation view of the hangeable or mountable electronic device of FIG. 1, illustrating the input side of the input assembly.

[0032] FIG. 5 is a rear elevation view of the hangeable or mountable electronic device of FIG. 1.

[0033] FIG. 6 is a front elevation view of the magnetically-mountable electronic device attached to a refrigerator in one embodiment.

[0034] FIG. 7 is a front perspective view of the magnetically-mountable electronic device of FIG. 6.

[0035] FIG. 8 is a front elevation view of the magnetically-mountable device of FIG. 6, illustrating the input side of the input assembly.

[0036] FIG. 9 is a rear elevation view of the magnetically-mountable electronic device of FIG. 6.

[0037] FIG. 10 is a top plan view of the input side of the input assembly in one embodiment.

[0038] FIG. 11 is an enlarged side elevation view of one shaft of the input assembly in one embodiment.

[0039] FIG. 12 is an enlarged side elevation view of the detachment assembly of the input assembly in one embodiment.

[0040] FIG. 13 is top perspective view of the data entry side of the detachable input assembly with guard walls in one embodiment.

[0041] FIG. 14 is top perspective view of the input side of the detachable input assembly of FIG. 13.

[0042] FIG. 15 is a schematic block diagram illustrating the electronic configuration or electronic system in one embodiment.

[0043] FIG. 16 is a perspective view of the in-console electronic device mounted within a vehicle seat in one embodiment.

[0044] FIG. 17 is a front perspective view of the in-console electronic device of FIG. 16.

[0045] FIG. 18 is a front elevation view of the in-console electronic device of FIG. 16, illustrating the input side of the input assembly.

[0046] FIG. 19 is a front perspective view of the in-vehicle electronic device mounted within a dashboard of a vehicle in one embodiment.

[0047] FIG. 20 is a front perspective view of the in-vehicle electronic device of FIG. 19, illustrating the multi-axis rotational functionality of the input assembly.

[0048] FIG. 21 is a front elevation view of the in-vehicle electronic device of FIG. 19, illustrating the data entry side of the input assembly.

[0049] FIG. 22 is a front elevation view of the in-vehicle electronic device of FIG. 19, illustrating the input side of the input assembly.

[0050] FIG. 23 is a schematic block diagram of the Read Only Memory (ROM) of the electronic device of FIG. 19 in one embodiment.

[0051] FIG. 24 is a front perspective view of the electronic notebook in one embodiment.

[0052] FIG. 25 is a front perspective view of the communication device in one embodiment.

[0053] FIG. 26 is a rear perspective view of the communication device of FIG. 25, illustrating the rear cover in a closed position.

[0054] FIG. 27 is a rear perspective view of the communication device of FIG. 25, illustrating the rear cover in an open position.

[0055] FIG. 28 is a top plan view of the data entry side of the communication device of FIG. 25 in one embodiment.

[0056] FIG. 29 is a top plan view of the telephone side of the communication device of FIG. 25 in one embodiment.

[0057] FIG. 30 is a side elevation view of the communication device of FIG. 25, illustrating the rotatable function of the input assembly.

[0058] FIG. 31 is a top plan view of the game side of the communication device of FIG. 25 in one embodiment.

[0059] FIG. 32 is a top plan view of the entertainment side or entertainment panel of the communication device of FIG. 25 in one embodiment.

[0060] FIG. 33 is a front perspective view of the mountable computer in one embodiment.

[0061] FIG. 34 is a front perspective view of the mountable computer of FIG. 33, illustrated with the keyboard removed.

[0062] FIG. 35 is a side elevation view of a slot and groove device used to couple a keyboard to a computer housing of a mountable computer in one embodiment.

[0063] FIG. 36 is a side elevation view of a pivot or hinge device used to couple a keyboard to a computer housing of a mountable computer in one embodiment.

[0064] FIG. 37 is a front elevation view of a computer having an opening below the display device for positioning of

the hands while the user is operating a keyboard, wherein the keyboard is connected to the lower portion of the computer housing in one embodiment.

[0065] FIG. 38 is a schematic block diagram of the electronic configuration or computer system in one embodiment.

[0066] FIG. 39 is a front perspective view of one embodiment of an assembly of the main unit mounted to the mounting unit, which, in turn, is mounted to the wall of a room, where the input assembly is open and the keyboard is facing upward.

[0067] FIG. 40 is a front perspective view of one embodiment of the assembly of FIG. 39.

[0068] FIG. 41 is a right side elevation perspective view of the assembly of FIG. 39.

[0069] FIG. 42 is a bottom perspective view of the assembly of FIG. 39.

[0070] FIG. 43 is a top perspective view of the assembly of FIG. 39.

[0071] FIG. 44 is a front perspective view of one embodiment of an assembly of the main unit mounted to the mounting unit, which, in turn, is mounted to the wall of a room, where the input assembly is closed and the display panel of the input assembly is oriented in a vertical plane.

[0072] FIG. 45 is a right side elevation perspective view of the assembly of FIG. 44.

[0073] FIG. 46 is a bottom perspective view of the assembly of FIG. 44.

[0074] FIG. 47 is a top perspective view of the assembly of FIG. 44.

[0075] FIG. 48 is a front perspective view of one embodiment of an assembly of the main unit mounted to the mounting unit, which, in turn, is mounted to the wall of a room, where the input assembly is open and the display panel of the input assembly is facing upward.

[0076] FIG. 49 is a left side elevation perspective view of the assembly of FIG. 48.

[0077] FIG. 50 is a right side elevation perspective view of the assembly of FIG. 48.

[0078] FIG. 51 is a bottom perspective view of the assembly of FIG. 48.

[0079] FIG. 52 is a top perspective view of the assembly of FIG. 48.

[0080] FIG. 53 is a left side elevation perspective view of one embodiment of an assembly of the main unit mounted to the mounting unit, which, in turn, is mounted to the wall of a room, illustrating input assembly being open and rotatable through three hundred sixty degrees.

[0081] FIG. 54 is a back perspective view of one embodiment of an assembly of the main unit mounted to the mounting unit, which, in turn, is illustrated apart from a wall or support structure.

[0082] FIG. 55 is a left side elevation exploded perspective of one embodiment of the main unit spaced apart from the mounting unit, illustrating the securing members of the mounting unit.

[0083] FIG. 56 is a left side elevation perspective view of one embodiment of the main unit after being dismounted and moved away from the mounting unit.

[0084] FIG. 57 is a left rear perspective view of one embodiment of the main unit, illustrating the stand closed.

[0085] FIG. 58 is a right rear perspective view of one embodiment of the main unit, illustrating the stand closed.

[0086] FIG. 59 is an exploded front perspective of one embodiment of the assembly illustrating the mount base,

mount cover, main unit, main faceplate, input assembly faceplate, and housing extension faceplates.

[0087] FIG. 60 is a front perspective view of one embodiment of the mounting unit.

[0088] FIG. 61 is an exploded front perspective view of one embodiment of the mounting unit, illustrating the base and the cover.

[0089] FIG. 62 is a front perspective view of one embodiment of the main unit standing on a support surface, illustrating the input assembly closed with the display panel facing outward.

[0090] FIG. 63 is a front perspective view of one embodiment of the main unit standing on a support surface, illustrating the input assembly detached from the arm assembly and including an enlarged view of the rotary coupler and the input assembly coupler.

[0091] FIG. 64 is a rear perspective view of the main unit of FIG. 62.

[0092] FIG. 65 is a front perspective view of the main unit standing on a support surface, illustrating the input assembly open with the keyboard upward.

[0093] FIG. 66 is a front perspective view of the main unit standing on a support surface, illustrating the input assembly open with the display panel upward.

[0094] FIG. 67 is a front perspective view of the main unit standing on a support surface, illustrating the input assembly detached from the main unit with the keyboard facing upward.

[0095] FIG. 68 is a front perspective view of the main unit standing on a support surface, illustrating the input assembly detached from the main unit and supported by its legs with the display panel facing upward.

[0096] FIG. 69 is a top plan view of one embodiment of an initial screen of an entertainment interface of the display panel of the input assembly.

[0097] FIG. 70 is a top plan view of one embodiment of a second screen of an entertainment interface of the display panel of the input assembly.

[0098] FIG. 71 is a top plan view of one embodiment of a third screen of an entertainment interface of the display panel of the input assembly.

[0099] FIG. 72 is a top plan view of one embodiment of a fourth screen of an entertainment interface of the display panel of the input assembly.

[0100] FIG. 73 is a top plan view of one embodiment of the initial screen of a medical calculator interface of the display panel of the input assembly.

[0101] FIG. 74 is a top plan view of one embodiment of a second screen of a medical calculator interface of the display panel of the input assembly.

[0102] FIG. 75 is a top plan view of one embodiment of a third screen of a medical calculator interface of the display panel of the input assembly.

[0103] FIG. 76 is a top plan view of one embodiment of a fourth screen of a medical calculator interface of the display panel of the input assembly.

[0104] FIG. 77 is a top plan view of one embodiment of a fifth screen of a medical calculator interface of the display panel of the input assembly.

[0105] FIG. 78 is a top plan view of one embodiment of a sixth screen of a medical calculator interface of the display panel of the input assembly.

[0106] FIG. 79 is a top plan view of one embodiment of a seventh screen of a medical calculator interface of the display panel of the input assembly.

[0107] FIG. 80 is a top plan view of one embodiment of a eighth screen of a medical calculator interface of the display panel of the input assembly.

[0108] FIG. 81 is a front isometric view of one embodiment of the electronic device.

[0109] FIG. 82 is a front view of the electronic device of FIG. 81.

[0110] FIG. 83 is a bottom isometric view of the back of the electronic device of FIG. 81.

[0111] FIG. 84 is a back view of the electronic device of FIG. 81.

[0112] FIG. 85 is a right side view of the electronic device of FIG. 81.

[0113] FIG. 86 is a left side view of the electronic device of FIG. 81.

[0114] FIG. 87 is a bottom view of the electronic device of FIG. 81.

[0115] FIG. 88 is a top view of the electronic device of FIG. 81.

[0116] FIG. 89 is an exploded, front isometric view of the electronic device of FIG. 81.

[0117] FIG. 90 is a front isometric view of the rear housing portion of the electronic device of FIG. 81.

[0118] FIG. 91 is an isometric view of the camera assembly of the electronic device of FIG. 81.

[0119] FIG. 92 is an isometric view of the camera assembly of FIG. 91, illustrating the lens and lens holder.

[0120] FIG. 93 is a side view of the camera assembly of FIG. 91.

[0121] FIG. 94 is a front isometric view of the electronic device of FIG. 81, illustrating the keyboard in the open position.

[0122] FIG. 95 is a right side view of the electronic device of FIG. 81, illustrating the keyboard in the open position.

[0123] FIG. 96 is a top isometric view of the electronic device of FIG. 81 with the transparent cover and upper housing portion removed.

[0124] FIG. 97 is a top isometric view of a portion of the electronic device of FIG. 81, illustrating one of the two keyboard position controllers.

[0125] FIG. 98 is a back elevation view of a portion of the electronic device of FIG. 81, illustrating one of the two keyboard sliders or release levers.

[0126] FIG. 99 is a back isometric view of a portion of the electronic device of FIG. 81, illustrating one of the two keyboard position controllers.

[0127] FIG. 100 is an enlarged, back isometric view of a portion of the electronic device of FIG. 81, illustrating one of the two keyboard position controllers.

[0128] FIG. 101 is an enlarged, back isometric view of a portion of the electronic device of FIG. 81, illustrating the different slide positions of the slider of one of the two keyboard position controllers.

[0129] FIG. 102 is an exploded, back isometric view of a portion of the electronic device of FIG. 81, illustrating one of the two keyboard position controllers.

[0130] FIG. 103 is an exploded, top isometric view of a portion of the electronic device of FIG. 81, illustrating one of the two keyboard position controllers.

[0131] FIG. 104 is an exploded, side isometric view of a portion of the electronic device of FIG. 81, illustrating one of the two keyboard position controllers.

[0132] FIG. 105 is an enlarged, front isometric view of the keyboard latch of the electronic device of FIG. 81.

[0133] FIG. 106 is an exploded, enlarged, front isometric view of the keyboard latch of the electronic device of FIG. 81.

[0134] FIG. 107 is an enlarged, back isometric view of the projection of the keyboard latch of the electronic device of FIG. 81.

[0135] FIG. 108 is an enlarged, front, bottom isometric view of the keyboard latch of the electronic device of FIG. 81.

[0136] FIG. 109 is an exploded, enlarged, side isometric view of the keyboard latch of the electronic device of FIG. 81.

[0137] FIG. 110 is an exploded, enlarged, back isometric view of the keyboard latch of the electronic device of FIG. 81.

[0138] FIG. 111 is a side view of the electronic device of FIG. 81, illustrating the desktop stand open and the electronic device resting on a desktop.

[0139] FIG. 112 is a top front isometric view of the electronic device of FIG. 81, illustrating the desktop stand open and the electronic device resting on a desktop.

[0140] FIG. 113 is a back isometric view of the desktop stand latch of the electronic device of FIG. 81.

[0141] FIG. 114 is a back isometric view of the desktop stand assembly of the electronic device of FIG. 81.

[0142] FIG. 115 is an exploded, enlarged isometric view of the desktop stand assembly of the electronic device of FIG. 81.

[0143] FIG. 116 is an exploded, enlarged side isometric view of the desktop stand assembly of the electronic device of FIG. 81.

DETAILED DESCRIPTION

1. Electronic Device Mountable to Upright Structures

[0144] Referring to FIGS. 1 through 15, the wall-mountable computer or electronic device 10 is attachable to or hangeable on a room wall 11, and the magnetically-mountable electronic device 100 is attachable to a refrigerator 101. The computers or electronic devices 10 and 100 each include the chassis or housings 12 and 102, respectively. Each of the housings 12 and 102, in one embodiment, houses or otherwise supports suitable circuitry components, hardware and software, such as the electronic system 152 described below with respect to FIG. 15. In one embodiment, each of the electronic devices 10 and 100 includes: (a) a monitor, screen or display device 14 supported by the housing of such electronic device, such as the substantially flat Liquid Crystal Diode (LCD) screen illustrated in the figures; (b) an input assembly 16 rotatably coupled to the housing 12; (c) a position control device 18 operatively coupled to the input assembly 16; (d) a compact disk drive 20 and a floppy disk drive 22; (e) a power button 24 and a plurality of different status indicators 26, such as Light Emitting Diodes (LEDs), operable to visually indicate the status of various operational parameters of the electronic device 10 or 100, in each case; (f) a plurality of data exchange devices or data ports 28 operable to couple external devices (such as flash memory sticks or removably data storage devices, printers, scanners and Personal Digital Assistants (PDAs)) to the electronic device 10 or 100 (in each case) through use of a data cable, cord or connector; (g) a slidable door 29 operable to cover the ports 28; (h) a plurality

of control buttons 30 operable to provide inputs for controlling settings for the display device 14 and performance settings for the electronic device 10 or 100 (in each case); (i) a plurality of sound output devices or speakers 32 operable to output music and other sounds; and (j) a signal receiving and transmitting device 34, such as a radio frequency (RF) transceiver, which wirelessly couples the processor 154 (shown in FIG. 15) to a data network, such as the Internet.

[0145] In one embodiment, the input assembly 16 of each electronic device 10 and 100 has: (a) a plurality of ends or end regions 36 and 37, each of which has a midpoint 39; (b) a plurality of sides or side regions 38; (c) a support or body 40 having a substantially flat data entry side 42 and a substantially flat input side 44; and (d) a plurality of spindles or shafts 46 and 48 which are rotatably coupled to the housing of such electronic device. The input assembly 16 is rotatable about axis 49, and, in one embodiment, the axis 49 passes through the midpoints 39.

[0146] In one embodiment, each of the lengths of the ends 36 and 37 has a length which is less than or equal to the width 50 of the housing 12 and 102, in each case. As such, the input assembly 16 is spinnable or rotatable about three hundred sixty degrees while the devices 10 and 100 are mounted to the wall 11 and refrigerator 13, respectively. In another embodiment, the ends 36 are greater than the width 50. Here, the user removes the devices 10 and 100 from the wall 11 and refrigerator 13, respectively, in order to spin or rotate the input assembly 16 through three hundred sixty degrees.

[0147] The data entry side 42 supports a data entry input device or keyboard 52, and the input side 44 supports a control panel, a plurality of control buttons, touch actuable areas or supplementary input devices 54. The input side 44 also supports a relatively small visual output device or supplementary display device 56, such as a miniature LCD screen.

[0148] The keyboard 52, in one embodiment, includes: (a) a plurality of touch actuable areas or movable keys 58 suitable for entering data; and (b) a keyboard processor 79 (illustrated in FIG. 11) operatively coupled to the keys 58 and to the processor 154 of the device 10 or 100, in each case. In one embodiment, the keyboard 52 includes a QWERTY keyboard having all of the alphabetic keys and one or more special keys, such as arrow keys, text editing keys, modifier keys and other suitable keys. In another embodiment, the keyboard 52 also includes a set of numeric keys. The keyboard 52 can have any suitable number and types of keys, and the keys can be full-sized keys or reduced-sized keys.

[0149] Though not illustrated, it should be understood that the keyboard 52 can include one or more of the numeric keys, function keys or any other keys of a commercially available enhanced keyboard having one hundred and one keys or one hundred and four keys. The keyboard 52 also includes a finger-steerable cursor mover, such as touch pad 60. In another embodiment, the keyboard 52 includes a built-in mouse or track ball mouse. The size of the keyboard 52 can vary with the size of the body 40 which, in turn, can vary with the size of the electronic device 10 or 100, in each case.

[0150] The supplementary input device 54 of the input side 44 are associated with any suitable input or output of the electronic device 10 or 100, in each case. In the example illustrated in FIGS. 4 and 8 the supplementary input device 54 are associated with controlling the output and performance of the audio system and video system of the electronic system 152. The supplementary input device 54 include audio-video buttons and indicators for controlling and monitoring play,

pause, skip forward, skip backward, repeat, random play, disk selection, sound track selection and other audio or visual functions. The supplementary display device 56 displays images related to the performance of the audio or video system of the electronic device 10 or 100, in each case. In the example illustrated, the supplementary display device 56 displays the play mode of the DVD video system.

[0151] In another example illustrated in FIG. 10, the input side 44 has supplementary buttons or input devices 62 and supplementary display device 64. The supplementary input devices 62 and supplementary display device 64 have functions related to the control of and monitoring of one or more medical devices in a health care facility, such as a hospital. In this example, the device 10 is hung on or otherwise secured to the wall of a hospital hallway or patient room. The device 10 is electronically coupled to one or more patient monitoring devices over an electronic health or hospital data network. In this embodiment, the electronic system 152 of the device 10 includes a plurality of medical-related software programs or computer code stored within ROM 162, described below with respect to FIG. 15. The functionality of the supplementary input devices 62, as determined by the electronic system 152, can have various patient monitoring functions. For example, by activating blood pressure button 66, the display device 14 or 64 indicates the blood pressure of a patient; by activating pulse button 68, the display device 14 or 64 displays a graph of the patient's pulse; by activating temperature button 69, the display device 14 or 64 indicates the temperature of a patient; and by activating video button 70, the display device 14 or 64 displays a live video of the patient.

[0152] It should be appreciated that, in other embodiments, the ROM 162 (described below) can store task-specific or industry-specific operating systems, applications and software suitable for use of the devices 10 and 100 in any suitable environment, including, but not limited to, health care facilities, factories, plants, restaurants, stores, retail enterprises, public facilities (such as airports, train stations, bus stations, road-side rest facilities and museums), police stations, prisons, military-related facilities, administrative buildings, municipal, state and federal buildings, court buildings, hotels, resorts, amusement parks, game rooms, stadiums and other facilities with a relatively high occupancy or flow of traffic. In each such case, the ROM 162 can store an operating system, software and programs which are specifically related to the purpose and function of such environments.

[0153] As illustrated in FIG. 11, in one embodiment, at least one of the shafts 46 and 48 includes an electrical rotary connector 72 which electrically or electronically couples the input assembly 16 to the processor 154 of the electronic system 152. In the illustrated example, the rotary connector 72 is a suitable slip ring assembly which includes: (a) a rotatable conductive contact member or rotor 74 connected to an electrical or data cord, cable, wire or wire assembly 76 which, in turn, is coupled to the processor 154; (b) a conductive contact member 78 coupled to the keyboard processor 79; (c) a holder or housing 80 which holds the rotor 74 and contact member 78 in contact with each other; and (d) a shaft member 83 which houses or receives part of the wire 81. In one embodiment, the rotor 74 includes a conductive brush which is engaged with the contact member 78. In operation, as the input assembly 16 is rotated or spun, the rotor 74 rotates relative to the contact member 78. Because the rotor 74 is in contact with the contact member 78, electricity and electronic signals can travel between the rotor 74 and contact member

78 while the input assembly 16 is rotating through a suitable angle or spinning through an angle of three hundred and sixty degrees.

[0154] In another embodiment illustrated in FIG. 12, the input assembly 16 is detachable from the housing 10 or 100, in each case. Here, the input assembly 16 includes: (a) a detachment assembly 81; (b) a receiving and transmitting device or transceiver 82 which wirelessly couples the input assembly 16 to the processor 154 of the electronic device 10 or 100, in each case; and (c) a rechargeable battery 85. The detachment assembly 81 is described herein only with respect to the left end 36 of the input assembly 16 because, in one embodiment, the left end 36 and right end 37 of the input assembly 16 each have the same structure, components and detachment assembly 81. The detachment assembly 81 includes: (a) a cavity wall 86 defining a cavity 88; (b) a shaft member 90 movably positioned within the cavity 88; (c) a biasing member or spring 92 housed within the cavity 88; (d) an arm 94 connected to the shaft member 90; and (e) a hand or finger grip 96 connected to the arm 94.

[0155] In this embodiment, the data entry side 42 and the input side 44 each include one or more feet, guard members or guard walls 98, as illustrated in FIGS. 13 and 14. The guard walls 98 extend from the surfaces 102 and 104 of the data entry side 42 and input side 44, respectively. The guard wall 98 has a lowered wall 99 which extends a length equal to or greater than the area of the keys 58 and supplementary input device 54.

[0156] To detach the input assembly 16 in this embodiment, the user slides the grip 96 toward the center of the input assembly 16, causing the shafts 46 and 48 to disengage from the housing of the electronic device 10 or 100, in each case. The user then detaches and removes the entire input assembly 16 from the housing of the device 10 or 100, as the case may be. The user then places the input side 44 face down on a table or on the user's lap. The data entry side 42 is then facing upward. The user types and enters data using the keyboard 56 of the data entry side 42 while the guard walls 98 and 99 protect and guard the supplementary display device 56 and supplementary input devices 54 of the input side 44. When ready to use the input side 44, the user flips the input assembly 16 over and positions the input side 44 facing upward. In this position, the data entry side 42 can lie face down on a table or on the user's lap. The user operates the supplementary input device 54 while the guard walls 98 and 99 protect and guard the keys 58 of the keyboard 52.

[0157] In one embodiment, the electronic devices 10 and 100 each include: (a) at least one electric motor; (b) a drive assembly which couples the motor to the input assembly 16, enabling the motor to power the rotational movement of the input assembly 16; and (c) a damper or speed control device coupled to the input assembly 16. The speed control device produces a drag force on the input assembly 16, which provides the input assembly 16 with a relatively smooth and steady rate of rotational movement.

[0158] 1.1. Wall Mount Housing

[0159] For the wall-mountable computer or electronic device 10 illustrated in FIGS. 1 through 5, the housing 12 has: (a) a perimeter wall 106 substantially lying in a single plane, providing the electronic device 10 with a relatively flat notebook-type configuration; (b) a front inner wall 108 defining a window, opening or input assembly space 110; (c) a rear side 112; and (d) a plurality of shaft supports 114 and 116. The input assembly space 110 provides an open area for the rota-

tional movement of the input assembly 16. In one embodiment, the space 110 is a recess rather than an opening that passes entirely through the electronic device 10. In another embodiment, the space 110 is an opening that passes entirely through the electronic device 10. In either embodiment, the rear side 112 of the housing 12 has one or more hang mount devices 118. Each hang mount device 118 has a mount wall 120 that defines a mount opening 122 to receive a head or other portion of a fastener, such as the head of a screw. The rear side 112 also has a battery door or cover 124 and a battery cover release device 126. In one embodiment, the shaft supports 114 and 116 define shoulders or openings which receive or otherwise rotatably support shafts 46 and 48, respectively, of the input assembly 16.

[0160] In operation of one example, the user screws a plurality of mounting screws (not illustrated) into a room wall 11, such as a kitchen or hospital wall. The user then engages the hang mount devices 118 by inserting the heads of the screws into the mount openings 122. In doing so, the user mounts the electronic device 10 to the room wall 11. If the rechargeable battery unit 163 (described below with respect to FIG. 15) is charged, the user can operate the electronic device 10 at this point. Alternatively, the user can obtain power for the electronic device 10 (and charge the battery unit) by connecting the power cord 128 to a nearby electrical outlet 130. In either case, the user connects the electronic device 10 to the Internet using the built-in transceiver 34 or using a data cable (not show) connected to a data outlet.

[0161] In one embodiment, the electronic device 10 is a kiosk-type machine mounted to the wall of a public facility, such as an airport or train station. Here, the electronic device 10 includes a data card reader and a payment acceptor, such as a coin slot or bill receiver. The user can operate the device 10 for a designated amount of time after funding the device 10.

[0162] 1.2 Magnetic Mount Housing

[0163] For the magnetic computer or electronic device 100 illustrated in FIGS. 6 through 9, the housing 102 has: (a) a perimeter wall 132 substantially lying in a single plane, providing the electronic device 100 with a relatively flat notebook-type configuration; (b) a front inner wall 134 defining a window, opening or input assembly space 136; (c) a rear side 138; and (d) a plurality of shaft supports 140 and 142. The input assembly space 136 provides an open area for the rotational movement of the input assembly 16. In one embodiment, the space 136 is a recess rather than an opening that passes entirely through the electronic device 100. In another embodiment, the space 136 is an opening that passes entirely through the electronic device 100. In either embodiment, the rear side 138 of the housing 102 has one or more magnets, magnetic layers or magnetic members, such as the substantially flat magnet 144. The magnet 144 is integrated with or fastened to the surface of the rear side 132. In one embodiment, the magnet 144 is adhered to the surface of the rear side 132 using a suitable adhesive. The rear side 132 also has a battery door or cover 146 and a battery cover release device 148. In one embodiment, the shaft supports 140 and 142 define shoulders or openings which receive or otherwise rotatably support shafts 46 and 48, respectively, of the input assembly 16.

[0164] In operation of one example, the user removably attaches and mounts the magnetic electronic device 100 to a metallic surface, such as a refrigerator 101, by bringing the rear side 138 into contact with the metallic door 150 of the refrigerator 101. If the rechargeable battery unit 163 (de-

scribed below with respect to FIG. 15) is charged, the user can operate the electronic device 100 at this point. Alternatively, the user can obtain power for the electronic device 10 (and charge the battery unit) by connecting a power cord (not illustrated) of the electronic device 100 to a nearby electrical outlet or to a refrigerator electrical source. In either case, the user can connect the electronic device 100 to the Internet using the built-in transceiver 34 or using a data cable (not show) connected to a data outlet.

[0165] 1.3 Electronic System

[0166] In one embodiment, the computers or devices 10 and 100 each have the computer system or electronic system 152 illustrated in FIG. 15. The electronic system 152 includes: (a) a central processing unit or processor 154 which is electronically coupled to the CD drive 20, floppy device 22, data ports 28, transceiver 34, input devices 156 and output device 158; (b) Random Access Memory (RAM) 160 electronically coupled to the processor 154; (c) Read Only Memory (ROM) 162 electronically coupled to the processor 154; and (d) a rechargeable battery unit 163 operatively coupled to the processor 154. The input devices 156 include the input assembly 16, power button 24 and control buttons 30. The output devices 158 include the display device 14, supplementary display device 56, status indicators 26 and speakers 32.

[0167] The ROM 162 includes computer-readable instructions which determine the operational activities of the processor 154. In one embodiment, the ROM 162 includes operating system code 164 associated with a suitable operating system. The ROM 162 also includes a plurality of software programs 166 usable by the processor 154 to run various applications, such as word processing applications, Internet browser applications, finance applications, business applications and entertainment applications.

2. In-Console Electronic Device

[0168] Referring to FIG. 16 through 18, the in-console computer or electronic device 200, in one embodiment, includes: (a) a chassis or housing 202 mounted, in the illustrated example, within the backside 203 of a vehicle seat 205; (b) a monitor, screen or display device 204 supported by the housing 202, such as the substantially flat Liquid Crystal Diode (LCD) screen illustrated in the figures; (c) the input assembly 16 (described above) rotatably coupled to the housing 202; (d) a position control device 206 operatively coupled to the input assembly 16; (e) a compact disk drive 208; (f) a power button 210 and a plurality of different status indicators 211, such as Light Emitting Diodes (LEDs), operable to visually indicate the status of various operational parameters of the electronic device 200; (g) a plurality of data exchange devices or data ports 212 operable to couple external devices (such as flash memory sticks or removably data storage devices, printers, scanners and Personal Digital Assistants (PDAs)) to the electronic device 200 through use of a data cable, cord or connector; (h) a plurality of control buttons 214 operable to provide inputs for controlling settings for the display device 204 and performance settings for the electronic device 200; (i) a plurality of sound output devices or speakers 216 operable to output music and other sounds; (j) at least one phone or headset audio output port 218 which enables a user to connect speakers or head phones 220 to the electronic device 200; and (k) a signal receiving and transmitting device 222, such as a radio frequency (RF) transceiver,

which wirelessly couples the processor 154 of the electronic system 152 to a data network, such as the Internet.

[0169] The housing 202 houses or otherwise supports suitable circuitry components, hardware and software, such as the electronic system 152 described above with respect to FIG. 15. The housing 202 has: (a) a perimeter wall 224 substantially lying in a single plane, providing the electronic device 200 with a relatively flat configuration; (b) a front inner wall 226 defining a window, opening or input assembly space 228; (c) a rear side 230; and (d) a plurality of shaft supports 232 and 234. The perimeter wall 224 has a console or seat engagement surface 226 which engages an inner portion of the seat 205. The input assembly space 228 provides an open area for the rotational movement of the input assembly 16. In one embodiment, the space 228 is a recess rather than an opening that passes entirely through the electronic device 200. In another embodiment, the space 228 is an opening that passes entirely through the electronic device 200. In either embodiment, the rear side of the housing 102 has one or more mount devices (not illustrated) which are operable to mount the housing 202 within a console or structure, such as the vehicle seat 205. In one embodiment, at least one of these mount devices includes a mount bracket or mount plate which defines a plurality of mount holes (not illustrated). The mount plate can be attached to the inner portion of the seat 205 with fasteners, bolts or screws that extend through the mount holes. This mount device also includes a coupling member which secures the housing 202 to the mount plate through a slidable, press-fit, rotary or fastener connection.

[0170] In one embodiment, the rear side (not illustrated) defines one or more wire holes or wire openings which enable electrical cords, wires or data cables to extend from the inside of the housing 202 to an electrical or computer system reachable within the seat 205. In another embodiment, the housing 202 includes a plurality of electrical or electronic contact devices, such as electrical harnesses, connected to the rear side 230. These contact devices are configured to removably mate with electrical or electronic contact devices or harnesses located within the seat 205. In one embodiment, the shaft supports 232 and 234 define shoulders or openings which receive or otherwise rotatably support shafts 46 and 48, respectively, of the input assembly 16. In one embodiment, the in-console electronic device 200 has the electronic system 152 having the audio output port 218 coupled to the processor 154.

[0171] In operation of one example, for each of the devices 10, 100, and 200, the user can operate the keyboard 52 for data entry purposes. The user can use the keyboard 52 to perform any personal computer activity or task, such as writing a letter, balancing a checkbook, composing and sending an email, paying bills online or surfing the World Wide Web portion of the Internet. To use the keyboard 52, the user unlocks the input assembly 16 using the position control device 18. Next, the user rotates the input assembly 16 from one position 229 to another position 230 where the keyboard 52 can be operated. In each of the positions 229 and 230, the input assembly 16 is parallel to or substantially parallel to the screen of the display device. The user can rotatably adjust the input assembly 16 until reaching a typing angle which is comfortable and ergonomically suitable to the user. When finished typing, the user can rotate the input assembly 16 back to the position 229 where the input side 44 faces outward. At this point, the user can perform a variety of functions by monitoring the supplementary display device 56 and activat-

ing the supplementary input devices or supplementary input devices **54**, as described above. In one embodiment, the input assembly **16** is rotatable or spinnable in a drum-like fashion through three-hundred sixty degrees.

3. In-Vehicle Electronic Device

[0172] Referring to FIG. **19** through **23**, the in-vehicle computer or electronic device **300**, in one embodiment, includes: (a) a chassis or housing **302** mounted, in the illustrated example, within the dashboard **304** of a vehicle **306**; (b) a monitor, screen or display device **308** supported by the housing **302**, such as the substantially flat Liquid Crystal Diode (LCD) screen illustrated in the figures; (c) the input assembly **16** described above; (d) an input assembly holder **310** rotatably coupled to the housing **302**; (e) a position control device **312** operatively coupled to the input assembly **16**; (f) a compact disk drive **314**; (g) a power button **316** and a plurality of different status indicators **318**, such as Light Emitting Diodes (LEDs), operable to visually indicate the status of various operational parameters of the electronic device **300**; (h) a plurality of data exchange devices or data ports **320** operable to couple external devices (such as flash memory sticks or removably data storage devices, printers, scanners and Personal Digital Assistants (PDAs)) to the electronic device **300** through use of a data cable, cord or connector; (i) a plurality of control buttons **322** operable to provide inputs for controlling settings for the display device **308** and performance settings for the electronic device **300**; (j) a plurality of sound output devices or speakers **324** operable to output music and other sounds; (k) at least one phone or headset audio output port **326** which enables a user to connect an audio input-output headset **328** (such as a microphone and ear speaker assembly) to the electronic device **300**; (l) a signal receiving and transmitting device (not illustrated), such as a radio frequency (RF) transceiver, which wirelessly couples the processor of the electronic system **152** to a data network, such as the Internet; and (m) computer programmed safety module or an electronic safety device **329** which operatively couples the electronic device **300** to the vehicle ignition or a designated vehicle drive mode, thereby causing the electronic device **300** or the input assembly **16** to be in off mode or inoperable when the vehicle **306** is on or in a designated mode of operation. In one embodiment, this safety device **329** causes the electronic device **200** to shut down when the user pivots the input assembly **16** toward the driver's seat while the vehicle **306** is in a designated mode of operation.

[0173] The housing **302** houses or otherwise supports suitable circuitry components, hardware and software, such as the electronic system **152** except that the ROM **162** is replaced with ROM **500** illustrated in FIG. **23**. ROM **500** includes a plurality of vehicle-related software programs or computer code, including, without limitation: (a) vehicle or car audio code or module **502** which directs the processor **152** to control the audio system of the vehicle **306**; (b) navigation code or navigation module **504** which includes global positioning satellite (GPS) code or a GPS module **506**; and (c) car or vehicle diagnosis code or diagnosis module **508** enabling technicians to diagnosis and trouble shoot problems with the vehicle **306** through use of the electronic device **300**.

[0174] The GPS module **506** includes a GPS receiver **510**. The GPS receiver **510** has an antenna (not illustrated) to receive signals from a satellite network and obtain the longitude, latitude and altitude of the vehicle **306**. The processor

154 causes the display device **308** to display a graphical map. The map is usable to provide positioning and navigational functions for the vehicle **306**.

[0175] The diagnosis module **506** includes an on-board diagnostics (OBD) module **508**, such as OBD I and OBD II of the U.S., for analyzing performance of the vehicle's engine, transmission, fuel system and other components. In one embodiment, the electronic device **300** is programmed to enable technicians, drivers and other users to diagnose the vehicle **306** using the input assembly **16** and display device **308**.

[0176] Referring back to FIGS. **20** through **22**, the housing **302** of the electronic device **300** has: (a) a perimeter wall **330** substantially lying in a single plane, providing the electronic device **330** with a relatively flat configuration; (b) a front inner wall **332** defining a window, opening or input assembly space **334**; (c) a rear side (not illustrated); and (d) a plurality of shaft supports **338** and **340**. The perimeter wall **330** has a console or dashboard engagement surface **342** which engages an inner portion of the dashboard **304**. The input assembly space **334** provides an open area for the rotational movement of the input assembly holder **310**. In one embodiment, the space **334** is a recess rather than an opening that passes entirely through the electronic device **300**. In another embodiment, the space **334** is an opening that passes entirely through the electronic device **300**.

[0177] In either embodiment, the rear side of the housing **302** has one or more mount devices (not illustrated) which are operable to mount the housing **302** within the dashboard **304** of the vehicle **306**. In one embodiment, at least one of these mount devices includes a mount bracket or mount plate which defines a plurality of mount holes (not illustrated). The mount plate can be attached to the inner portion of the dashboard **304** with fasteners, bolts or screws that extend through the mount holes. This mount device also includes a coupling member which secures the housing **302** to the mount plate through a slidable, press-fit, rotary or fastener connection.

[0178] In one embodiment, the rear side defines one or more wire holes or wire openings which enable electrical cords, wires or data cables to extend from the inside of the housing **302** to an electrical or computer system reachable within the dashboard **304**. In another embodiment, the housing **302** includes a plurality of electrical or electronic contact devices, such as electrical harnesses, connected to the rear side **336**. These contact devices are configured to removably mate with electrical or electronic contact devices or harnesses located within the dashboard **304**. In one embodiment, the shaft supports **338** and **340** define shoulders or openings which receive or otherwise rotatably support shafts **344** and **346**, respectively, of the input assembly holder **310**.

[0179] The input assembly holder **310** includes: (a) a support or frame **348** sized to surround the input assembly **16**; (b) a plurality of side coupler supports of shaft supports **350** which rotatably couple the input assembly **16** to the frame **348**; (c) and a plurality of couplers or shafts **352** which pivotably or rotatably couple the frame **348** to the inner wall **332** of the housing **302**. In operation, the input assembly **16** is rotatable about a horizontal axis **49** through a designated angle or through three hundred sixty degrees. In addition, the input assembly holder **310** is pivotable or rotatable about vertical axis **354** which intersects with and, in the illustrated embodiment, is perpendicular to the axis **49**. The input assembly holder **310** is pivotable or rotatable about the vertical axis **354** through a designated angle or through three hundred

sixty degrees. In the illustrated embodiment, the driver can pivot the input assembly 16 (about vertical axis 354) toward his/her seat, and then the driver can rotate the input assembly 16 (about the horizontal axis 49) to a desired position for typing on the keyboard 52 or using the supplementary control input devices 54. Likewise, the front seat passenger can pivot the input assembly 16 (about vertical axis 354) toward his/her seat, and then the front seat passenger can rotate the input assembly 16 (about axis 49) to a desired position for typing on the keyboard 52 or using the supplementary control input devices 54. As such, the input assembly holder 310 provides the input assembly 16 with at least two degrees of pivotal or rotational freedom—side to side rotational freedom and upward/downward rotational freedom.

4. Electronic Notebook

[0180] Referring to FIG. 24, the computer notebook or electronic notebook 356, in one embodiment, includes the structure, components and functionality of the electronic device 100 except the electronic notebook: (a) does not include the magnetic member 144; and (b) includes a touch screen module or device 358 within the display device 14. As such, the electronic notebook 356 is a portable and mobile personal computer with a substantially integral and flat configuration. While supporting the notebook 356 on a table or other support surface, the user can use the input device 16 to enter data or make other inputs. Optionally, the user can use the display device 14 to enter data and provide inputs to the notebook 356.

5. Hand-Held Mobile Devices

[0181] 5.1 Phone/PDA Module

[0182] Referring to FIGS. 25 through 32, the mobile phone, PDA or communication device 600, in one embodiment, includes: (a) a chassis or housing 602; (b) a display device 604, such as an LCD screen, supported by the housing 602; (c) a touch actuation device (not illustrated) coupled to the display device 604; (d) the input assembly 16 having a size suitable for being positioned within the space 605 defined by the inner wall 606 of the housing 602; (e) an audio input device or microphone 608; (f) an ear audio output device or ear speaker 610; (g) an audio output device or loud speaker 612; (h) an audio input/output jack or audio port 614 connectable to a headset wire or cord; (i) data port 613; (j) a light source (not illustrated) coupled to the input assembly 16 and operable to illuminate the input assembly 16; (k) a receiving and transmitting device or transceiver which wirelessly couples the communication device 600 to a data network, enabling the communication device 600 to wirelessly exchange communication signals and data with other devices operating on such network; (l) a removable rechargeable battery which is operable to power the communication device 600; (m) a processor and memory device coupled to the processor; and (n) a communication and data processing module or code stored by the memory device.

[0183] In the illustrated embodiment, the space 605 passes entirely through the housing walls 616. The movable rear panel, door or cover 618 is slidable between an open position 620 and a closed position 622 through slots 621. As illustrated in FIGS. 25 and 28, the data entry side 623 of the input assembly 16 supports or carries a keyboard 624. The telephone side 625 of the input assembly 16 supports or carries a telephone control panel 626, as illustrated in FIGS. 27 and 29.

The telephone control panel 626 includes: (a) a standard telephone keypad 627 having the standard telephonic alphanumeric convention or system; (b) a multi-directional cursor mover 628; (c) a volume control device 630; and (d) a plurality of telephone control-related buttons including a connect button 632, disconnect button 634, mute button 636, speaker phone button 638, hold button 639 and redial button 641.

[0184] As illustrated in FIG. 30, the user can rotate the input assembly 16 to switch between using the phone functionality and data processing functionality of the communication device 600. In one example, the user first slides the cover 618 upward to its open position 620. Opening the cover 618 provides room or openness for the input assembly 16 to freely rotate. This enables the user to rotate the input assembly 16 through one hundred eighty or three hundred sixty degrees, as illustrated in FIG. 30. When the user has positioned the desired side 623 or 625 at the front 643 of the communication device 600, the user closes the cover 618. The closing of cover 618 guards the space 605 from debris and also guards the input assembly 16 against damage by foreign objects.

[0185] 5.2 Game Play Module

[0186] Referring to FIG. 31, in one embodiment, the communication device 600 has a game play module used by the processor of the communication device 600. Here, the communication device 600 stores or accesses a plurality of game programs which are accessible to the device 600 through a wire-based or wireless connection to an electronic game program source, such as a personal computer or webserver. In this embodiment, one side (not illustrated) of the input assembly 16 supports or carries keyboard 626, keypad 626, telephone control panel 626 or any suitable combination thereof.

[0187] The opposite, game side 640 supports or carries a game control panel 642. The game control panel 642 includes: (a) a plurality of relatively flat-configured joysticks 643; (b) a multi-directional pad 644 enabling the user to control the upward, downward, left and right movement or travel of a character or game-related image displayed by the display device 604; (c) a command pad 646 having a plurality of command buttons associated with different game commands, for example, jump, shoot, fly or run; and (d) a plurality of general game play buttons 648, for example, a start button, mode button, pause button, repeat button or select button. The user can use one side of the input assembly 16 to operate keyboard 624, telephone control panel 626, keypad 627 or any suitable combination thereof. When ready for games, the user can rotate the input assembly 16 one hundred eighty degrees and use the game side 640 to operate the game control panel 642.

[0188] 5.3 Entertainment Module

[0189] Referring to FIG. 32, in one embodiment, the communication device 600 has an entertainment module having entertainment-related code used by the processor of the device 300 to provide music, video and photo display functionality. Here, the communication device 600 stores or accesses a plurality of songs, videos and photos which are accessible to the device 600 through a wire-based or wireless connection to song, video and photo sources, such as personal computers or web servers. In this embodiment, one side (not illustrated) of the input assembly 16 supports or carries keyboard 624, telephone control panel 626, keypad 627 or any suitable combination thereof.

[0190] The opposite side 650 supports or carries an entertainment panel 652. The entertainment panel 652 includes a relatively flat-configured joystick, input device or touch pad

654. The touch pad **654** has: (a) a menu input **656** enabling the user to access a menu of a plurality of songs, videos or photos and also enabling the user to select a desired song, video or photo to play or view; (b) a forward input **658** enabling the user to advance forward in a song, compilation of songs, video, compilation of videos or photo set; (c) a backward or reverse input **660** enabling the user to move backward or reverse in a song, compilation of songs, video, compilation of videos or photo set; and (d) a dual functional play/pause input **662** with play and pause functionality, enabling the user to activate play of a song or video or to pause play of a song or video. The user can use one side of the input assembly **16** to operate keyboard **624**, telephone control panel **626**, keypad **627** or any suitable combination thereof. When ready for entertainment, the user can rotate the input assembly **16** one hundred eighty degrees and use the opposite side **650** to operate the entertainment panel **652**.

[0191] 5.4 Camera & Video Recording Module

[0192] In one embodiment, the communication device **600** includes a digital camera device (not illustrated) and a video recorder (not illustrated), each of which is controlled by the processor of the device **600**. One or more of the sides of the input assembly **16** can carry camera input devices and video recorder input devices.

[0193] 5.5 Vibration Device

[0194] In one embodiment, the communication device **600** includes an electro-mechanical vibration device (not illustrated). The vibration device produces a vibration within the device **600** when a designated event occurs. The designated event can be a telephone call transmitted when the device **600** is placed in silent or vibrate mode. The designated event can also be a designated game event, such as a danger event, point losing event or other event associated with a loss in game success.

6. Mountable Computer

[0195] Referring to FIGS. **33** through **37**, the mountable computer **436** is securable to an upstanding structure (not illustrated), such as a wall, seat or dashboard. It should be understood that the upstanding structure need not be perpendicular to a horizontal plane. The computer **436** includes: (a) a central processing unit (CPU) or processor **438** which controls a display device **440**; (b) a keyboard **442** which enables a user to provide inputs to the processor **438**; (c) a memory device **444** used by the processor **438** to perform a plurality of computer functions; (d) one or more speakers **441** for outputting sound; and (e) a housing **446** which houses the processor **438** and memory device **444** and which also supports the display device **440** and the keyboard **442**.

[0196] The display device **440** has a screen **448** which is flat or substantially flat. Therefore, the screen **448** is substantially positionable in a plane. The keyboard **442** has: (a) a top surface **450**; (b) a plurality of key input devices or keys **449** on the top surface **450**; (c) a front side region or front side **451**; (d) a back side region or back side **453**; and (e) a plurality of end regions or ends **467**, each of which has a length **455**, midpoint **457** and portions **459** and **461**. The top surface **450** is also substantially flat and therefore substantially positionable in a plane. In addition, the keyboard **442** has a cylindrical-shaped or semi-cylindrical shaped bottom surface. As described below, the user can adjust the position of the keyboard **442**, through an angle **463**, so that the top **450** of the keyboard **442** and the screen **448** substantially lie in the same plane.

[0197] The housing **446** has a back surface (not illustrated) which is engageable with the upstanding structure, and the housing **446** has a front surface **452** and a plurality of outer walls **465**. In one embodiment, the front surface **452** is an integral, one-piece member constructed of a single mold. The front surface **452** has a plurality of walls **454** that define a screen opening (not illustrated) or a screen region **456**. The screen opening is positioned in line with the screen **448** of the display device **440**. The walls **454** surround the screen **448**, enabling the user to view the screen **448** through the screen opening.

[0198] In addition, the front surface **452** has a keyboard region **460** located below the screen region **456**. The front surface **452** has a plurality of inner walls or walls **462** defining a cut-away, space or cavity **464** within the keyboard region **460**; and (b) at least one, and preferably a plurality of spaced apart coupling members **466** positioned within the keyboard region **460**. The coupling members **466** are positioned along a common axis **468**. In the embodiment illustrated in FIGS. **35** through **37**, the coupling members **466** are rods or shafts which function as pivot points for the ends **467** of the keyboard **442**. Here, the walls **462** function, in part, as guard members that protect the keyboard **442** from impact from people and objects.

[0199] The keyboard **442** is pivotable or rotatable between a first or closed position and a second or open position. In the closed position, the keyboard **442** is upwardly rotated or pivoted until the plane of the top surface **450** of the keyboard **442** is substantially parallel with the plane of the screen **448**. In this position, the keyboard **442** is least likely to be damaged caused by contact with a person or an object passing by the computer **436**. In addition, the closed keyboard **442** causes the computer **436** to occupy less space. In the open position, keyboard **442** is downwardly rotated or pivoted until the plane of the top surface **450** of the keyboard **442** is substantially perpendicular to or otherwise intersects with the plane of the screen **448**. In this open position, illustrated in FIG. **33**, the keyboard **442** has a conventional horizontal operating position even though the screen **448** has a vertical position. This makes is convenient for users to operate the keyboard **442** while standing, for example, in a kitchen.

[0200] In one embodiment, the housing **446** includes a keyboard position control device **469**. In the illustrated embodiment, the position control device **469** includes a plurality of equally spaced-apart protrusions. The protrusions are positioned on the ends **467** of the keyboard **442**. These protrusions removably mate with a plurality of slots (not illustrated) defined by each of the end walls **471** of the keyboard region **460**. In operation, the user applies a certain degree of force in order to unseat the protrusions from the slots to reposition the keyboard **442**.

[0201] In addition, the computer **436** has a plurality of securing members **470**. Each securing member **470** includes a wall **472** which extends from the front surface **452** through the back surface of the computer **436**. The wall **472** defines a fastener opening that is sized and shaped so as to receive a suitable screw, bolt or other fastener (not illustrated). The user can affix or secure the computer **436** to an upstanding structure, such as a kitchen wall, by inserting such fasteners through such fastener openings and securing the fasteners to the upstanding structure. Also, the securing members **470** include lock members or devices **474**. The lock devices **474**, in one embodiment, include a keyhole which enable only a user with a key to access such fasteners.

[0202] In one embodiment, the computer 436 has at least one hand-controlled input device other than the keyboard 442. In the illustrated example, the computer 436 has a touch pad 476 positioned on the keyboard 442. In other embodiments, the computer 436 has a mouse, a trackball and/or a stylus. The computer 436 also has plurality of standard input or control buttons 477 which enable the user to control certain settings of the computer 436 as well as the power of the computer 436.

[0203] The computer 436 also has a plurality of ports or connection devices 479 located on the front surface 452 of the housing 446 for convenient access. Here, a sliding door 481 is movable to cover and expose the connection devices 479. In one embodiment, a personal digital assistant (PDA) is connectable to one of these ports 479, and the computer 436 includes a PDA holder, PDA arm or another type of PDA support member adapted to support one or more PDA's. In addition, the computer 436 includes a hard disk drive 483 and a drive 485 which functions as a CDROM (Compact Disk-Read-Only Memory) drive and a DVD (Digital Video Disk) drive.

[0204] Referring to FIG. 35, in one embodiment, the housing 446 of the computer 436 includes a sliding coupling device 478 which slidably couples the keyboard 442 to the housing 446. The coupling device 478 includes an arc-shaped slot wall 480 positioned on each of the end walls 471 of the housing 446. Also, the coupling device 478 includes a protrusion member 482 connected to each end 467 of the keyboard 442. The protrusion member 482 is received by and mates with the slot wall 480. This enables the user to adjust the keyboard 442 by sliding the keyboard 442 along the arc-shaped slot wall 480.

[0205] As illustrated in FIG. 36, in one embodiment, the housing 446 of the computer 436 includes a pivoting coupling device 484 which pivotally couples the keyboard 442 to the housing 446. The coupling device 484 includes a hinge, pin, or shaft 486 coupled to each of the wall ends 471 of the keyboard region 460. Each of the shafts 486 is engaged with one of the ends 467 of the keyboard 442. This enables users to pivot the keyboard 442 upward and downward.

[0206] In another embodiment illustrated in FIG. 37, the computer 436 has a housing 488 which includes a screen region 490 and a keyboard region 492 located below the screen region 490. The housing 488 has a plurality of walls 494 that define a cavity 496. The cavity 496 extends from the front through the backside of the computer 436. The cavity 496 is sufficiently sized and shaped so as to receive the user's hands while the user is operating the keyboard 497. In this embodiment, the keyboard 497 is non-movably or rigidly connected to the lower wall 498 of the housing 488. It should be appreciated, however, that in other embodiments, the keyboard 497 can be adapted to have a designated incline or an angle adjustment device.

[0207] In another embodiment, the computer 436 has an electronic configuration including a processor, a system controller, a cache, and a data-path chip, each coupled to a host bus. The processor is a microprocessor such as a 486-type chip, a Pentium®, Pentium® II, Pentium® III, Pentium® 4, or other suitable microprocessor. The cache provides high-speed local-memory data (in one embodiment, for example, 512 kB of data) for the processor, and is controlled by the system controller, which loads the cache with data that is expected to be used soon after the data is placed in the cache (i.e., in the near future).

[0208] The main memory is coupled between the system controller and data-path chip, and in one embodiment, provides random-access memory of between 16 MB and 256 MB or more of data. In one embodiment, the main memory is provided on SIMMs (Single In-line Memory Modules), while in another embodiment, the main memory is provided on DIMMs (Dual In-line Memory Modules), each of which plugs into suitable sockets provided on a motherboard holding other components. The main memory includes standard DRAM (Dynamic Random-Access Memory), EDO (Extended Data Out) DRAM, SDRAM (Synchronous DRAM), or other suitable memory technology. The system controller controls PCI (Peripheral Component Interconnect) bus, a local bus that provides a high-speed data path between the processor and various peripheral devices, such as graphics devices, storage drives and network cabling.

[0209] A data-path chip is also controlled by the system controller to assist in routing data between the main memory, the host bus, and the PCI bus. In one embodiment, the PCI bus provides a 32-bit-wide data path that runs at 33 MHz. In another embodiment, the PCI bus provides a 64-bit-wide data path that runs at 33 MHz. In yet other embodiments, the PCI bus provides 32-bit-wide or 64-bit-wide data paths that run at higher speeds. In one embodiment, PCI bus provides connectivity to an I/O bridge, a graphics controller, and one or more PCI connectors (i.e., sockets into which a card edge may be inserted), each of which accepts a standard PCI card. In one embodiment, the I/O bridge and the graphics controller are each integrated on the motherboard along with the system controller, in order to avoid a board-connector-board signal-crossing interface and thus provide better speed and reliability.

[0210] In this embodiment, the graphics controller is coupled to a video memory (that includes memory such as DRAM, EDO DRAM, SDRAM, or VRAM (Video Random-Access Memory)), and drives a VGA (Video Graphics Adaptor) port. The VGA port can connect to industry-standard monitors such as a VGA-type, SVGA (Super VGA)-type, XGA-type (eXtended Graphics Adaptor) or SXGA-type (Super XGA) display devices.

[0211] Other input/output (I/O) cards having a PCI interface can be plugged into the PCI connectors. The network connections providing video input are also represented by the PCI connectors, and include Ethernet devices and cable modems for coupling to a high speed Ethernet network or cable network which is further coupled to the Internet.

[0212] In one embodiment, the I/O bridge is a chip that provides connection and control to one or more independent IDE or SCSI connectors, to a USB (Universal Serial Bus) port, and to an ISA (Industry Standard Architecture) bus. In this embodiment, the IDE connector provides connectivity for up to two standard IDE-type devices such as hard disk drives, CDROM (Compact Disk-Read-Only Memory) drives, DVD (Digital Video Disk) drives, videocassette recorders, or TBU (Tape-Backup Unit) devices. In one similar embodiment, two IDE connectors are provided, and each provide the EIDE (Enhanced IDE) architecture. In the embodiment shown, a SCSI (Small Computer System Interface) connector provides connectivity for up to seven or fifteen SCSI-type devices (depending on the version of SCSI supported by the embodiment).

[0213] In one embodiment, the I/O bridge provides an ISA bus having one or more ISA connectors (in one embodiment, three connectors are provided). In one embodiment, the ISA

bus is coupled to the I/O controller, which in turn provides connections to two serial ports, a parallel port, and a FDD (Floppy-Disk Drive) connector. At least one serial port is coupled to a modem for connection to a telephone system providing Internet access through an Internet service provider. In one embodiment, the ISA bus is connected to a buffer, which is connected to an X bus, which provides connections to a real-time clock, a keyboard/mouse controller and a keyboard BIOS ROM (Basic Input/Output System Read-Only Memory) 345, and to a system BIOS ROM.

[0214] The computer 436 performs several functions. Such functions are implemented in software in one embodiment, where the software comprises computer executable instructions stored on computer readable media such as disk drives coupled to connectors, and executed from the main memory and the cache. The term "computer readable medium" is also used to represent carrier waves on which the software is transmitted.

[0215] It should be appreciated that each of the computer 436 can have any size which is suitable for its application. In one embodiment, the screen of the computer is sized similar to that of a conventional personal computer. In another embodiment, the computer is miniaturized or relatively small so that the computer can be mounted within a dashboard of a vehicle.

[0216] The computer 436 has a built-in keyboard which is positioned or positionable for operation while the computer is secured to an upstanding structure, such as a wall. The wall-mountable computer brings the functionality of the personal office computer to those involved in carrying out household activities on a regular basis. The integrated keyboard enables the computer to be relatively thin which, in turn, safeguards the computer and enhances the aesthetics of the computer. This type of computer provides a relatively high degree of convenience to computer users.

[0217] In one embodiment illustrated in FIG. 38, the electronic system 152 described above is replaced or integrated with the computer system 700. Computer system 700 includes a microprocessor 702 with access to a system memory device 704, each of which is connected to a bus 704. Bus 704 serves as a connection between microprocessor 702 and other components of computer system 700. The input assembly 16 is coupled to microprocessor 702 to provide input to microprocessor 702. Programs and data are stored on a mass storage device 706, which is coupled to microprocessor 702. Mass storage devices include such devices as hard disks, optical disks, magneto-optical drives, floppy drives and the like. Each display device 14, 64, 204, 308 and 604 is coupled to microprocessor 702 by a video controller 708. A system memory 710 is coupled to microprocessor 702 to provide the microprocessor 702 with relatively fast storage to facilitate execution of busses. Intermediate circuits can be deployed between the components described above and microprocessor 702 to facilitate interconnection between the components and the microprocessor 702.

[0218] It should be appreciated that the electronic devices and computers described herein can include any information handling system which, in turn, can include any instrumentality or aggregate of instrumentalities operable to compute, classify, process, transmit, receive, retrieve, originate, switch, store, display, manifest, detect, record, reproduce, handle, or utilize any form of information, intelligence, or data for business, scientific, control, entertainment or other purposes. For example, an information handling system may be a personal

computer, a network storage device, or any other suitable device and may vary in size, shape, performance, functionality, and price. The information handling system may include RAM, one or more processing resources such as a central processing unit (CPU) or hardware or software control logic, ROM, and/or other types of nonvolatile memory. Additional components of the information handling system may include one or more disk drives, one or more network ports for communicating with external devices as well as various input and output (I/O) devices, such as input assembly 16 and a video display. The information handling system may also include one or more buses operable to transmit communications between the various hardware components.

[0219] In one embodiment, the input assembly 16 (or the computer or electronic device attached thereto) includes one or more of the following elements: (a) a credit card or data card reader enabling data on a user's data card to be read by the processor of the input assembly 16 or the processor of the electronic device or computer on which the input assembly 16 is mounted; (b) an illuminated bezel, panel or cord bordering one or both of the sides of the input assembly 16; (c) one or more light sources coupled to or housed within such cord; (d) one or more supplementary pointing devices such as mice, trackballs and trackpads; and (e) a remote control device having a laser or signal generator and a remote control panel with a plurality of buttons or other suitable input devices mounted on one side of the input assembly 16, including, but not limited to, a television remote control, DVD player remote control, stereo remote control and garage door opener or other remote opener.

7. Assembly of Main Unit and Mounting Unit

[0220] 7.1 General

[0221] Referring now to FIGS. 39 through 80, in one embodiment, the assembly 800 includes a main unit 802 which is detachably connected to, or removably attached to, a mounting unit 804. The main unit 802 is operable in conjunction with and apart from the mounting unit 804. For example, the main unit 802 is mountable to the mounting unit 804 as illustrated in FIGS. 39-54, and the main unit 802 is demountable from the mounting unit 804 as illustrated in FIGS. 55-58 and 62-68.

[0222] 7.2 Main Unit

[0223] In one embodiment, the main unit 802 is a computer, for example, a personal computer of the type referred to as an all-in-one computer. The main unit 802 has: (a) a housing 806; (b) a motherboard (not illustrated) supported by the housing; (c) a display device having a display screen 808 operatively coupled to the motherboard; (d) a rechargeable battery unit (not illustrated) operatively coupled to the motherboard; (e) one or more radio frequency (RF) transmitters and receivers or RF transceivers (not illustrated) operatively coupled to the motherboard; (f) a plurality of audio output devices, such as speakers 810 and at least one subwoofer speaker (not illustrated), each of which is operatively coupled to the motherboard; (g) an input assembly 812 configured to be removably or non-removably coupled to the arm assembly 814; (h) a camera-microphone apparatus 816 including a web camera unit, digital camera unit and a microphone unit, each of which is operatively coupled to the motherboard; (i) one or more control devices operatively coupled to the motherboard, such as power button 826; (j) a hard drive and at least one disk drive operatively coupled to the motherboard, such as compact disk/digital video disk (CD/DVD) drive 828; (k) a plu-

rality of data ports operatively coupled to the motherboard, such as four Universal Serial Bus (USB) ports **830**, one or more miniature USB ports (not illustrated), an audio port **832**, a microphone-in port **834**, and one or more network ports (not illustrated) for a wire-based connection to the Internet or another data network; (l) a television (TV) mode button **836** operatively coupled to a TV tuner which, in turn, is operatively coupled to the motherboard; (m) an electrical connector **838** operable for powering the main unit **802** and charging the battery of the main unit **802**; and (n) an electrical chord **840**, as illustrated in FIGS. **62-67**, having one end connectable to the electrical connector **838**, the other end connectable to an alternating current (AC) source, such as an electrical outlet of a building, and an adapter or transformer (not illustrated) operable to transform AC to direct current (DC), also known as an AC/DC transformer.

[0224] Depending upon the embodiment, the main unit **802** can have any suitable dimensions. In one embodiment illustrated in FIG. **64**, the display screen **808** is a seventeen inch screen, and the main unit **802** has: (a) a height (H) of approximately 16.60 inches or 41.40 centimeters; (b) a width (W) of approximately 16.63 inches or 42.24 centimeters; and (c) a thickness (T) of approximately 2.94 inches or 7.47 centimeters.

[0225] In one embodiment, the motherboard of the main unit **802** is sized and shaped to fit within the housing **806**, located partially or fully behind the display screen **808**. The motherboard, in one embodiment, is a circuit board having part or all of the structure, components and functionality of the motherboard of a commercially available laptop personal computer.

[0226] It should be appreciated that the main unit **802** can have any suitable computer operating system, including, but not limited, to: (a) any operating system which is commercially available under the trademark, MICROSOFT™; or (b) any operating system which is commercially available under the trademark, MACINTOSH™.

[0227] In one embodiment, the camera-microphone apparatus **816** is movably coupled to the housing **806**. The camera-microphone apparatus **816** includes a ball joint, hinge or other coupler which enables the user to adjust the pointing direction of the camera-microphone apparatus **816**. For example, the user can tilt the camera-microphone apparatus **816** downward to take a digital photo of a child, and the user can tilt the camera-microphone apparatus **816** upward, to the left or to the right to take a digital photo of objects in various locations relative to the main unit **802**.

[0228] In one embodiment, the main unit **802** has one or more parallel ports operatively coupled to the motherboard. In another embodiment, the main unit **802** has a plurality of different data ports, operatively coupled to the motherboard. Depending upon the embodiment, either such data port is sized and configured to be connected to a video game device, a camera, a camcorder, a mobile phone, a personal digital assistant (PDA), a musical instrument, a stereo system, a home theater system, a TV, a medical instrument, a medical apparatus, a medical machine, a cash register, a data card interface device (such as a credit card swiper), or any other electronic peripheral device.

[0229] In one embodiment, the TV tuner includes a circuit board or card which enables television and radio signals to be received by the main unit **802**. In one embodiment, the TV tuner has a video capture card enabling the main unit **802** to record television programs onto the hard drive of the main

unit **802**. In one embodiment, the TV tuner includes a receiver, tuner, demodulator and an analog-to-digital converter for analog TV. In one embodiment, the TV tuner has flash memory large enough to hold the firmwares for decoding several different video formats, enabling the TV tuner to be operable in many countries. In one embodiment, the frequency tuner has a composite video input. In one embodiment, the TV tuner functions as a frequency modulation (FM) radio and also provides reception for satellite data signals. In one embodiment, the TV tuner is operable to enable the main unit **802** to play TV and radio programs in analog or digital format, whether broadcasted through cable, satellite, telephone, fibre optics other communication mediums.

[0230] In one embodiment, the housing **806** has a panel-shaped configuration including: (a) a plurality of spaced-apart legs or housing extensions **840**, each of which has a movable or pivotable arm **842**; and (b) a rear, backside or back **844**. The area or space **845** between the housing extensions **840** is, in one embodiment, a passageway extending entirely through the main unit **802**. Each housing extension **840** has an arm hinge **846** which pivotably couples such extension **840** to one of the arms **842**. In one embodiment, the arms **842** collectively constitute the arm assembly **814**.

[0231] Referring to FIG. **63**, each of the arms **842** has a rotary coupler **848**. The rotary coupler **848** has: (a) a torque producer (not illustrated); (b) one torque connector (not illustrated) which attaches such torque producer to such arm **842**; and (c) another torque connector **850** which is configured to attach the torque producer to one of the ends of the input assembly **812** as described below. In the embodiment illustrated, the torque connector **850** includes a gear having a plurality of teeth. The torque connector **850** defines a cylindrical-shaped opening **852** sized to receive, and mate with, the gear portion **902** of one of the input assembly couplers **898**, as described further below.

[0232] Depending upon the embodiment, the torque producer of the rotary coupler **848** can include: (a) one or more bushings secured to a rod; (b) a spring secured to a rod; (c) a torsion bar or torsion device; or (d) any other suitable type of device which is operable to produce torque between two parts along an axis. In one embodiment, the rotary coupler **848** includes some or all of the components of a commercially available friction hinge used to pivotably attach the display screens of laptop computers to the housings of such laptop computers.

[0233] In one embodiment, the main unit **802** has an input assembly closer (not illustrated). The input assembly closer can have any suitable configuration, including, but not limited to: (a) one or more notches or recess members configured to engage with the arm assembly **814** as described below; (b) a latch mechanism having an actuator configured to engage with the arm assembly **814** as described below; (c) a lock mechanism having an actuator configured to engage with the arm assembly **814** as described below; and (d) any suitable fastener configured to engage with the arm assembly **814** as described below. The input assembly closer enables the user to lock or set the arm assembly **814** in the closed arm position **856** illustrated in FIGS. **44-47**.

[0234] In one embodiment, each arm **842** of the arm assembly **814** is pivotable between: (a) an open arm position **854**, as illustrated in FIGS. **39-43**; and (b) a closed arm position **856** as illustrated in FIGS. **44-47**. In one embodiment, the angle between the open arm position **854** and closed arm position **856** is between zero and ninety degrees. In other embodi-

ments not illustrated, such angle is one hundred eighty degrees or an angle of any other suitable magnitude. In one embodiment, each arm 842 includes a stop (not illustrated) which limits the opening of such arm 842 to a designated angle. In one embodiment, one or each arm 842 has a position regulator (not illustrated) which enables the user to set the position of the arm 842 to a desired or designated angle or position. In one embodiment, one or each arm 842 has a closer engager (not illustrated) configured to engage with the input assembly closer of the main unit 802. The closer engager can have any suitable configuration, including, but not limited to: (a) one or more notches or recess members which co-act with the one or more notches or recess members of the input assembly closer of the main unit 802; and (b) an arm, rod, pin or other member configured to co-act with the input assembly closer of the main unit 802.

[0235] The back 844 of the housing 806 has: (a) a handle 858 usable to demount and carry the main unit 802 from one position to another; (b) a plurality of non-electrical mount engagers 860; (c) at least one electrical mount engager 862 operable for powering and charging the main unit 802; and (d) a movable stand 864. The movable stand 864 is movable between: (a) a closed stand position 866 as illustrated in FIGS. 53-58; and (b) an open stand position 868 as illustrated in FIGS. 62-68. A user can move the stand 864 to the closed stand position 866 for mounting the main unit 802 to the mounting unit 804. The user can later move the stand 864 to the open stand position 868 for standing the main unit 802 on a desk, tabletop, lap or other support surface 870. In the open stand position 868, the stand 864 increases the stability of the main unit 802 to facilitate standing the main unit 802 on the support surface 870.

[0236] In one embodiment, the handle 858 includes a grip 872. The back 844 of the housing 806 defines a handle cavity 874 sized to receive part of the user's fingers or hand. In operation, the user grasps the grip 872 while inserting his/her fingers into the handle cavity 874. In another embodiment not illustrated, the handle 858 includes a grip which is movably coupled to the back 844 of the housing 806. In such embodiment, the grip is movable between: (a) a recessed position where the grip fits within a cavity sized to receive part or all of the grip; and (b) a non-recessed or outward position where the grip extends outwardly to facilitate grasping by the user.

[0237] Referring to FIGS. 55-61, in one embodiment, each one of the non-electrical mount engagers 860 has a stud-shaped or cylindrical-shaped configuration including: (a) an inner retainer or disk-shaped base 876 spaced-apart from an outer retainer or disk-shaped head 878; and (b) a rod-shaped neck between the base 876 and head 878. The diameter of such neck is less than each of the diameters of the base 876 and head 878. As such, the base 876 and head 878 define a slot or cavity sized to receive a portion of the mounting unit 804, as described further below.

[0238] Referring to FIGS. 55-56 and 59-61, in one embodiment, the electrical mount engager 862 includes an electrical interface (not illustrated) which is operable to electrically connect the main unit 802 to the mounting unit 804. In one embodiment, the electrical interface includes a positive terminal or metal contact spaced part from a negative terminal or metal contact. In one embodiment, each such metal contact is electrically coupled to the motherboard and battery, and each such metal contact is dome-shaped or otherwise protrudes from the body of the electrical mount engager 862. When the electrical mount engager 862 is in contact with the electrical

interface of the mounting unit 804, described below, the mounting unit 804 is operable to power the main unit 802 and charge the battery of the main unit 802.

[0239] Referring to FIGS. 56 and 64, in one embodiment, the movable stand 864 has: (a) a stand hinge 880 coupled to the back 844 of the housing; (b) a hinge connector 882 connected to the stand hinge 880; (c) a plurality of spaced-apart legs 884 connected to the hinge connector 882; and (d) a foot 886 connected to the legs 884. In one embodiment, the foot 886 has a friction increaser 888, such as a rubber pad or foam, operable to reduce slippage of the stand 864 relative to the support surface 870.

[0240] Depending upon the embodiment, the input assembly 812 can include a single input side or multiple input sides. In one embodiment, the input assembly 812 includes a rectangular-shaped support or housing 860 which has: (a) a keyboard 890; (b) a display panel 892 located on the opposite side of the housing 860; and (c) a left end 894 and a right end 896.

[0241] As illustrated in FIGS. 39-41, 43, 65 and 67, the keyboard 890 includes a set of keys for typing. If the user desires to use the display panel 892, the user can flip or rotate the input assembly 812 to access the display panel 892 at a desired angle, as illustrated in FIGS. 48-50, 52 and 66.

[0242] In one embodiment, the display panel 892 includes a touch screen 893 and a navigation input or navigation button 895. The touch screen 893 has a pressure sensitive device which recognizes inputs made by the force of a user's finger or a pointed object. The touch screen 893 produces different input signals when the user presses different areas of the touch screen 893.

[0243] The navigation button 895 includes a central button 897 surrounded by a plurality of directional buttons 899. The directional buttons 899 are arranged at different angles relative to the center of the circular navigation button 895. Each directional button 899 is associated with a direction of movement for a graphical cursor, pointer, indicator or marker displayed by the touch screen 893. In operation, the user can use his/her finger or a pointed object to make inputs directly on the touch screen 893. Alternatively, if the user desires, the user can press the directional buttons 899 to move a graphical marker to a desired position on the touch screen 895, and the user can then press the central button 897 to make an input or selection.

[0244] In one embodiment, the entire housing of the input assembly 812, including the keys of the keyboard 890, is constructed of a material or composition which deters the growth or spread of harmful microorganisms, such as bacteria, viruses and fungi. In one embodiment, the keyboard 890 and its keys include an anti-microbial additive composition added to the resin of the polymeric material used to construct the keyboard 890 and its keys.

[0245] Referring to FIG. 63, the left end 894 and right end 896 of the input assembly 812 each include an input assembly coupler 898. The input assembly couplers 898 (only one of which is illustrated in FIG. 63) rotatably couple the input assembly 812 to the arm assembly 814. Referring to FIG. 63, in one embodiment, the input assembly coupler 898 includes a cylindrical-shaped member having an inner shaft portion 900 and an outer gear portion 902. The shaft portion 900 has a rounded or dome-shaped head sized to be received by the opening 852 of the rotary coupler 848. With the shaft portion 900 inserted into the opening 852, the gear portion 902 mates with the teeth of the torque connector 850.

[0246] In one embodiment, the input assembly couplers **898**, left and right, are identical, and each such coupler **898** rotatably mates with one of the torque connectors **850**. In another embodiment, one or each of the input assembly couplers **898** has a retraction device (not illustrated) which has a spring (not illustrated) coupled to a latch (not illustrated). By operating the latch, the user can retract the shaft portion **900** so that it moves in a direction toward the center of the input assembly **812**. With the shaft portion **900** retracted, the user can detach, or otherwise remove, the input assembly **812** from the main unit **804**, as illustrated in FIGS. **63**, **67** and **68**.

[0247] In one embodiment, the housing **860** of the input assembly **812** houses: (a) a keyboard circuit board (not illustrated) operatively coupled to the keyboard **890**; (b) a control panel circuit board (not illustrated) operatively coupled to the display panel **892**; (c) an RF receiver and RF transmitter or a RF transceiver (not illustrated) operable to electronically and wirelessly couple the input assembly **812** to the motherboard of the main unit **802**; and (d) a battery operatively coupled to such keyboard circuit board and control panel circuit board. In operation, the RF transceiver of the input assembly **812** exchanges radio frequency signals with the RF transceiver of the main unit **802**, and such radio wave communication couples the input assembly **812** to the main unit **802**.

[0248] Depending upon the embodiment, the battery of the input assembly **812** can include: (a) one or more single use or non-rechargeable batteries (not illustrated); or (b) one or more rechargeable batteries (not illustrated). Referring to FIG. **63**, in the embodiment with rechargeable batteries, each rotary coupler **848** has an electrical terminal electrically connected to the motherboard of the main unit **802**. Likewise, each input assembly coupler **898** has an electrical terminal electrically connected to the rechargeable batteries of the input assembly **812**. As such, when the input assembly **812** is connected to the main unit **802**, the main unit **802** charges the batteries of the input assembly **812** until reaching a full charge state.

[0249] Referring to FIG. **68**, in one embodiment, the left and right ends **894** and **896** of the input assembly **812** each include an input assembly leg **904**. It should be understood that only the left input assembly leg **904** is illustrated in FIG. **68**. In one embodiment, each input assembly leg **904** has: (a) a coupler portion **906** which defines an opening (not illustrated); (b) a pin or other fastener which extends through such opening, rotatably connecting the coupler portion **906** to the input assembly **812**; (c) a main portion **908** which is pivotable between a closed leg position **910** and an open leg position **912**; (d) a position regulator (not illustrated) which is operable to maintain the input assembly leg **904** in the closed position **910**, open position **910** or another designated open position until the user applies a threshold force to readjust the input assembly leg **904**. The position regulator may have any suitable configuration, including, but not limited to, one or more notch and recess members which co-act with each other in a snap-fit fashion. Because, in one embodiment, each input assembly leg **904** is positioned adjacent to a side of the input assembly **812**, the input assembly legs **904** do not cover or interfere with the viewing of, or accessibility to, the keyboard **890** or display panel **892**. When the user detaches the input assembly **812** from the main unit **804**, the user can open the input assembly legs **904** to provide a desired typing angle for the user, as illustrated in FIG. **68**.

[0250] Referring to FIG. **53**, when the input assembly **812** is attached to the main unit **804**, the input assembly **812** is

movable along an arc **914**, and the input assembly **812** is also rotatable about a longitudinal axis **916** which extends between the two input assembly couplers **898**. These multiple degrees of freedom are present while the main unit **804** is mounted to the mounting unit **804** as illustrated in FIG. **53**, and these multiple degrees of freedom are also present while the main unit **804** is demounted.

[0251] Once the main unit **804** is mounted to the mounting unit **804**, the main unit **804** can have several operational positions. In one example illustrated in FIGS. **39-43**, the input assembly **812** is open, which causes the input assembly **812** to be moved away from the mounting unit **804** and the upstanding support structure **918** by a designated distance. Such distance and the space **845** enables the user to rotate the input assembly **812** to a desired typing position for use of the keyboard **890**.

[0252] When finished typing, the user can close the input assembly **812**, for example, as illustrated in FIGS. **44-47**. To do so, the user pushes the input assembly **812** upward while rotating the input assembly **812** so that the display panel **892** or keyboard **890** is substantially parallel to the display screen **808**. In the example illustrated in FIGS. **44-47**, the display panel **892** faces outward when the input assembly **812** is closed. As such, the user can use the display panel **892** in such vertical position for basic or relatively quick operations as described below. It should be appreciated, however, that the user can alternatively rotate the input assembly **812** so that the keyboard **890** faces outward when the input assembly **812** is closed.

[0253] Referring to FIGS. **48-52**, the user can open, swing-out and rotate the input assembly **812** so that the display panel **892** is faced upward, oriented at a desired angle for making inputs at the display panel **892**. With reference to FIGS. **40** and **53**, in one embodiment, when the arm assembly **814** is open, the user can repeatedly spin or rotate the input assembly **812** through three hundred sixty degrees. In the course of each such revolution, a portion of the input assembly **812** extends into the space **845**. Also, during such rotation, it should be understood that the rotary couplers **848** provide a resistance force to counter such rotational movement. Such resistance force, in one embodiment, is sufficient to keep the input assembly **812** from rotating despite the force exerted by the user's arms, wrists and hands while typing on, or using, the input assembly **812**.

[0254] When the user removes the main unit **804** from the mounting unit **806**, the user can use the main unit **804** in any desired suitable fashion. In one example not illustrated, the user can operate the main unit **804**, like a tablet computer, with the back **844** of the main unit **804** lying on a support surface. In another example illustrated in FIGS. **62-68**, the user can operate the main unit **804**, like a desktop computer, with the main unit **804** standing on a support surface **870**. The user can open the arm assembly **814** so that the arms **842** and the input assembly **812** are in contact with, and supported by, the support surface **870**. In such example, the input assembly **812** is connected to the arm assembly **814**. The user can rotate the input assembly **812** so that the display panel **892** is upward, as illustrated in FIG. **66**. The user also has the option of detaching the input assembly **812** from the main unit **804**, as illustrated in FIGS. **67** and **68**, and operating the input assembly **812** apart from the main unit **804**.

[0255] 7.3 Mounting Unit

[0256] Referring to FIGS. **54-56** and **59-61**, the mounting unit **804**, in one embodiment, includes: (a) a base **920** which

is attachable to a vertical or upstanding support structure **918**, such as column or room wall; and (b) a cover **922** configured to mask or cover part of the mounting unit **804**. In one embodiment, the base **920** houses an adapter or transformer operable to transform AC to DC, also known as an AC/DC transformer (not illustrated).

[0257] Referring to FIGS. **55** and **61**, the base **920** includes: (a) a face **923**; (b) a plurality of fastener walls **924**, each of which defines an opening, hole or edge which is configured to be received by, or engaged with, a fastener such as a bolt or screw **926**; (c) an electrical connector **928** electrically connected to such AC/DC transformer; (d) an electrical chord **930** having one end connectable to the electrical connector **928** and another end connectable to an AC source, such as an electrical outlet of a building; (e) an electrical mount **932** electrically connected to such AC/DC transformer; (f) a plurality of non-electrical mounts **934**; and (g) a plurality of locks, inserts or mount securing devices **936** configured to secure the main unit **804** to the mounting unit **806**.

[0258] Referring to FIG. **60**, in one embodiment, the electrical mount **932** includes a positive terminal or metal contact and a negative terminal or metal contact. Such terminals can have any suitable configuration. In one embodiment, each such terminal has a concave shape to mate with the convex or dome shape of the terminals of the electrical mount engager **862** of the main unit **802**. When the user mounts the main unit **802** on the mounting unit **804**, the electrical mount **932** charges the battery unit of the main unit **804** until such battery unit has a full charge state. In addition to having an electrical function, the electrical mount **932** also supports the weight of the main unit **804** when the main unit **804** is mounted. In this sense, the electrical mount **932** has both electrical and non-electrical functionality.

[0259] Referring to FIGS. **56** and **60**, in one embodiment, each non-electrical mount **934** has a U-shaped outer wall **937** spaced apart from an inner wall **939**. When the main unit **804** is mounted, the disk-shaped head **878** of each mount engager **860** rests in the space between the inner wall **939** and the U-shaped outer wall **937**. At the same time, the vertical slot **941** defined by the U-shaped outer wall **937** receives the neck of the mount engager **860**. As such, the U-shaped outer wall **937** provides a retainer function, decreasing the likelihood that the main unit **804** might unintentionally be demounted or laterally pulled away from the mounting unit **806**. In addition to this retainer function, the non-electrical mounts **934** support the weight of the main unit **804**.

[0260] In one embodiment, referring to FIG. **55**, each mount securing device **936** is shaped to mate with one of the non-electrical mounts **934**, and each mount securing device **936** defines a plurality of fastener openings **938** sized to receive a plurality of fasteners, such as bolts or screws **940**. To secure the main unit **804** to the mounting unit **806**, the user screws the mount securing devices **936** into the non-electrical mounts **934**, entrapping the disk-shaped heads **878** of the main unit **804**. The installation of the mount securing devices **936** provides a theft deterrent function as well as additional coupling functionality.

[0261] In another embodiment not illustrated, the mount securing device includes a lock having a key opening, and such lock secures the main unit **804** to the mounting unit **806** as a theft deterrent function. In one embodiment not illustrated, the mount securing device includes a chain or steel cable which harnesses the main unit **804** to the mounting unit **806** through the use of a pad lock or other suitable lock.

[0262] Referring to FIG. **61**, in one embodiment, the cover **922** includes: (a) a plurality of upper walls **942** which define a plurality of upper openings **944**; (b) a lower wall **946** which defines a lower opening **948**; and (c) an artistic item holder, such as a picture holder **950**, connected to the face **951** of the cover **922**. In one embodiment, each upper opening **944** has the same geometric shape as the perimeter of the non-electrical mount **934** received by such upper opening **944**. In one embodiment, each upper opening **944** is only slightly larger than the perimeter of such non-electrical mount **934**. In one embodiment, the lower opening **946** has the same geometric shape as the perimeter of the electrical mount **932** received by such lower opening **948**. In one embodiment, each upper opening **944** is only slightly larger than the perimeter of such non-electrical mount **934**.

[0263] In one embodiment, the cover **922** is fastenable to the base **920** through a snap-fit or press-fit process. It should be appreciated, however, that any suitable fastener can be used to attach the cover **922** to the base **920**, including, but not limited to, adhesives, double-sided tape, and hook and loop fasteners.

[0264] In one embodiment, the picture holder **950** includes a front wall **952**, a lower wall **954**, and a plurality of side walls **956**. The upper end **958** of the picture holder **950** is open, enabling the user to slide a photograph, picture or other substantially flat object into the picture holder **950**. In one embodiment not illustrated, the picture holder only includes a single bent arm which is predisposed to apply a force to the face **951** of the cover **922**. In one embodiment, the front wall **952** is fully or partially transparent or translucent, enabling the user to view the object inserted into the picture holder **950**.

[0265] In other embodiments not illustrated, the picture holder includes: (a) a clasp device operable to releasably hold an item; (b) a plurality of vertical tracks or rails sized to receive vertical edges of a photograph or picture; (c) a plurality of horizontal tracks or rails sized to receive horizontal edges of a photograph or picture; (d) a plurality of track members seated within a plurality of grooves which enable the user to adjust the size of the picture holder for differently sized photographs and pictures; or (e) a device having any suitable combination of the foregoing elements.

[0266] By attaching the cover **922** to the base **920**, the cover **922** masks or covers the heads of the screws **926**. When the main unit **804** is demounted, the mounting unit **806** displays the photograph, picture or artistic object inserted into the picture holder **950**. This facilitates coordinating the appearance of the mounting unit **806** with the decoration of the environment.

[0267] In one embodiment not illustrated, an alternate cover is sized with an area greater than the mounting unit **806**. Here, the alternate cover is usable when the main unit **804** is demounted. The alternate cover has a thickness which is greater than the thickness of the mounting unit **806**. In addition, the alternate cover is configured to be removably attached to the mounting unit **806**. Due to the thickness of the alternate cover, the alternate cover defines an inner space which receives and covers all (or substantially all) of the components of the mounting unit **806**. In one embodiment, the alternate cover has couplers configured to releasably attach the alternate cover to the non-electrical mounts **934** when the main unit **804** is demounted. In another embodiment, one or more of the walls of the alternate cover are configured to removably engage with the mounting unit **806** in a snap-fit fashion. In one embodiment, the alternate cover

is a box-shaped picture frame having a plurality of windows to hold pictures. In another embodiment, the alternate cover is a convex-shaped picture frame having a plurality of windows to hold pictures.

[0268] In one example, the user carries out the following steps to use the main unit **804** with the mounting unit **806**:

[0269] (a) hold the base **920** against the upstanding support structure **918**, using the base **920** as a template to make six marks on the upstanding support structure **918** corresponding to the six circular fastener walls **924**;

[0270] (b) remove the base **920** from the wall;

[0271] (c) drill a hole (not illustrated) on each one of the six marks on the upstanding support structure **918**;

[0272] (d) insert six anchors (not illustrated) in such holes;

[0273] (e) align the fastener walls **924** of the base **920** with such anchors;

[0274] (f) screw a screw **926**, through the base **920**, into each one of such anchors, as illustrated in FIG. **61**;

[0275] (g) snap the cover **922** onto the base **920**, as illustrated in FIG. **60**;

[0276] (h) connect the electrical chord **930** to the mounting unit **806** and to an electrical outlet;

[0277] (i) lift the main unit **804** and mount it to the mounting unit **806**, as illustrated in FIG. **56**; and

[0278] (j) if desired for security reasons, screw the mount securing devices **936** to the main unit **804** and mounting unit **806**, as illustrated in FIG. **55**.

[0279] 7.4 Faceplates

[0280] Referring to FIG. **59**, in one embodiment, the main unit **804** has a plurality of removable covers or faceplates including main faceplate **955**, input assembly faceplate **957** and extension faceplates **959**. The faceplates **955**, **957** and **959** are removable for purposes of: (a) cleaning such faceplates; or (b) replacing such faceplates with replacement faceplates of the same color, a different color or replacements bearing different messages or symbols. In one embodiment, the main faceplate **955** has a transparent pane, cover or surface **965**, though such surface can be translucent, tinted or otherwise incorporate a privacy characteristic. The main faceplate **955** is configured to cover the face or front **961** of the housing **806**. Also, the main faceplate **955** has a plurality of couplers, such as bent walls, configured to be detachably connected to portions of the front **961**. In one embodiment, the main faceplate **955** is removably attached to the front **961** in a snap-fit fashion. It should be appreciated, however, that main faceplate **955** can be removably attached to the front **961** through the use of any suitable fastener, including, but not limited to, hook and loop fasteners, snaps and screws.

[0281] The input assembly faceplate **957** is configured to cover the face or front **963** of the display panel **892** of the input assembly **812**. Also, the input assembly faceplate **957** has a plurality of couplers, such as bent walls, configured to be detachably connected to portions of the display panel **892**. In one embodiment, the input assembly faceplate **957** is removably attached to the display panel **892** in a snap-fit fashion. It should be appreciated, however, that input assembly faceplate **957** can be removably attached to the display panel **892** through the use of any suitable fastener, including, but not limited to, hook and loop fasteners, snaps and screws.

[0282] Each extension faceplate **959** is configured to cover the face or front **963** of a housing extension **840**. Also, the extension faceplate **959** has a plurality of couplers, such as bent walls, configured to be detachably connected to portions

of the front **963**. In one embodiment, the extension faceplate **959** is removably attached to the front **963** in a snap-fit fashion. It should be appreciated, however, that extension faceplate **959** can be removably attached to the front **963** through the use of any suitable fastener, including, but not limited to, hook and loop fasteners, snaps and screws.

[0283] 7.5 Logic and Interfaces for Control Panel

[0284] The display panel **892** of the input assembly **812** has a graphical user interface which displays a plurality of visual outputs and inputs. In one embodiment, the main unit **804** stores or accesses a software program which is executable to control such graphical user interface. The software program has a plurality of computer-readable instructions organized with a logic which is suitable for controlling such graphical user interface.

[0285] In one embodiment illustrated in FIGS. **69-72**, the display panel **892** has an entertainment interface **960** including example screens **962**, **964**, **966** and **968**. Referring to FIG. **69**, example screen **962** displays: (a) a top horizontal menu **970** of selectable inputs including CAMERA, CALCULATOR, TV, AUDIO/VIDEO and MORE; (b) a television and audio control set **972** including a plurality of selectable numbers, volume control inputs, play, forward, pause, mute, sleep and other audiovisual inputs; and (c) a level control set **974** including a plurality of slidable bars for adjusting the balance and the levels of bass, treble and other audiovisual parameters; (d) an ADVANCED input **975** for making advanced audiovisual settings; (e) a shortcut input set **976**, including favorites MOVIES, OTHERS, KIDS, NEWS and SPORTS; (f) a data and clock output **978**; and (g) a weather output **980**. In one embodiment, the weather output **980** is periodically updated by a webserver connected to the main unit **804** over the Internet. For example, the user can subscribe to an online weather service of a weather website, and the service could periodically download weather data to the weather output **980**.

[0286] In the illustrated example, the user uses his/her finger or the navigation button **895** to select the FAVORITES input of screen **962**. Then, the user advances to screen **964** illustrated in FIG. **70**. Screen **964** displays the favorite input set **982** in place of the shortcut input set **976**. In this example, the favorite input set **982** displays a plurality of selectable TV channels.

[0287] If, rather than selecting the FAVORITES input of screen **962**, the user selects the AUDIO/VIDEO input of screen **962**, this results in the display of screen **966** illustrated in FIG. **71**. Screen **966** displays the audio meters **984** in place of the favorite input set **982**. Next, the user uses his/her finger or the navigation button **895** to select the ADVANCED input **975**, resulting in screen **968** illustrated in FIG. **72**. Screen **968** displays a plurality of audio inputs to adjust a plurality of audio settings, including an equalizer and a plurality of other sound effect settings.

[0288] In one embodiment illustrated in FIGS. **73-74**, the display panel **892** has a medical calculator interface **986** including example screens **988** and **990**. Referring to FIG. **73**, example screen **988** displays: (a) a top horizontal medical menu **992** of selectable inputs including MEDICAL REFERENCE, MEDICAL CALCULATOR, and MEDICAL TOOLS; (b) a vertical medical menu **994** of selectable inputs including a PREGNANCY CALCULATOR, TARGET HEART RATE CALCULATOR, GROWTH PERCENTILE CALCULATOR, MEDICAL CALCULATOR 1, MEDICAL CALCULATOR 2, and MEDICAL CALCULATOR 3 and a

plurality of additional medical calculators and medical reference resources which are viewable by moving the scroll bar **996** downward; and (c) a general calculator **996**.

[0289] In the illustrated example, the user uses his/her finger or the navigation button **895** to select the PREGNANCY CALCULATOR input of vertical medical menu **994**. Then, the user advances to screen **990** illustrated in FIG. **74**. Screen **990** has an interactive pregnancy calculation form **1000** and the general calculator **998**. The pregnancy calculation form **1000** includes a plurality of pull-down menus for entering data.

[0290] As illustrated in FIG. **75**, the user then uses his/her finger or the navigation button **895** to select the TARGET HEART RATE CALCULATOR input of vertical medical menu **994**. This causes the user to advance to screen **1002** illustrated in FIG. **76**. Screen **1002** has an interactive heart rate form **1004** and the general calculator **998**. The user can enter data into the heart rate form **1004** by entering data with the general calculator **998**. When the user selects the SHOW TARGET HEART RATE CALCULATOR input **1006**, the medical calculator interface **986** replaces the heart rate form **1004** with the heart rate data **1008** illustrated in FIG. **77**.

[0291] As illustrated in FIG. **78**, the user then uses his/her finger or the navigation button **895** to select the GROWTH PERCENTILE CALCULATOR input of vertical medical menu **994**. This causes the user to advance to screen **1010** illustrated in FIG. **79**. Screen **1010** has an interactive growth form **1012** and the general calculator **998**. The growth form **1012** has a plurality of data fields and a plurality of pull-down menus. The user can enter data into the growth form **1012** by entering data with the general calculator **998**. When the user selects the GET RESULTS input **1014**, the medical calculator interface **986** replaces the growth form **1012** with the growth percentile data **1016** illustrated in FIG. **80**.

[0292] As exemplified by the above description, the display panel **892** enables the user to adjust settings and controls for the main unit **804** in one embodiment. In another embodiment, the display panel **892** enables the user to make calculations and retrieve information. In one embodiment, the display panel **892** is operable without having to power-on or boot-up the main unit **804**. In addition, the display panel **892** is operable to output useful audio, visual or audiovisual information, including, but not limited, to time, date, alarm, weather, temperature, news, stock prices and other time-sensitive data.

[0293] In one embodiment, the main unit **804** is connected to a webserver which causes healthcare-related advertisements to be displayed on the display panel **892**. In one embodiment, the main unit **804** cooperates with such webserver to track the frequency or total display time of the advertisements displayed by the display panel **892**. In one example, the advertisement provider gives financial incentives in exchange for the display of advertisements, such as advertisements for pharmaceutical products.

[0294] The following is one embodiment of a business method:

[0295] (a) pharmaceutical company A desires to circulate advertisements to promote company A's pharmaceutical product;

[0296] (b) pharmaceutical company A provides multiple assemblies **802** to a hospital at no charge;

[0297] (c) such hospital agrees to: (i) permit company A to control the display of such product advertisements by each main unit **804**; and (ii) permit company A to display

a certain quantity of advertisements (or a certain amount of display time of advertisements) per month;

[0298] (d) company A connects each main unit **802** in the hospital to the advertisement webserver owned or controlled by company A or its advertisement agent;

[0299] (e) the display panel **892** of each main unit **802** displays such product advertisements while the main unit **804** is mounted to the hospital walls, enabling patients, healthcare providers and passersby to view such advertisements;

[0300] (f) the display panel **892** displays such advertisements whether the main unit **802** is on or off; and

[0301] (g) such advertisements vary from time to time and include videos, animations, useful medical information or other suitable audio, visual or audiovisual outputs.

[0302] 7.6 Supplemental Devices

[0303] In one embodiment, the assembly **802** includes or incorporates: (a) a printer device having an ink holder; and (b) a paper holder movably coupled to the main unit **804** or mounting unit **806**. In one embodiment, the paper holder includes a pivotable or movable arm sized to hold the paper dispensed by such printer.

[0304] In one embodiment, the assembly **802** includes one or more light sources, such as light emitting diodes (LEDs), a lamp, or a built-in flashlight, which automatically activates when a power outage or some other designated event occurs.

[0305] In one embodiment, the assembly **804** includes: (a) an environmental sensor, including, but not limited to, a smoke detector, carbon monoxide detector, temperature sensor, light sensor, or motion detector; and (b) an output device which produces an audible or visual output when a designated condition is present.

[0306] In one embodiment, the mounting unit **806** includes a chord cover which extends downward from the bottom end of the mounting unit **806** toward a floor, electrical outlet or data source. The chord cover, in one embodiment, is a pipe or conduit which receives and covers the electrical chord **840** and other data cables extending from the main unit **804**.

[0307] 7.7 Ancillary Devices

[0308] In one embodiment, the main unit **804** has one or more attachers or ancillary couplers (not illustrated). Each ancillary coupler is connected to (or integrated into) the housing **806** of the main unit **804**, and the ancillary coupler is configured to releasably or removably attach an ancillary device (not illustrated) to the main unit **804**. By way of example, the ancillary coupler can include: (a) a recess or cavity formed into the main unit **804** or mounting unit **806**; or (b) an arm, a hand, a hook, a harness, a band, a line, a net or a fastener connected to the main unit **804** or the mounting unit **806**. As such, when the main unit **804** is mounted to a room wall, for example, the user can attach ancillary devices to the mounted main unit **804**. Doing so can increase the convenience of accessing ancillary devices.

[0309] Depending upon the embodiment, the ancillary device may or may not be electronically connectable to the main unit **804**. In one embodiment, the ancillary device is electronic, and in another embodiment the ancillary device is non-electronic. In different embodiments, the ancillary devices include the following devices:

[0310] (a) a camera configured to be removably connectable to such ancillary coupler;

- [0311] (b) a dry erase board, bulletin board, or roll-up flexible dry erase board removably connectable to such ancillary coupler;
- [0312] (c) a clip or clasp removably connectable to such ancillary coupler;
- [0313] (d) a flashlight configured to be removably connected to such ancillary coupler;
- [0314] (e) any computer peripheral device, including, but not limited to, a printer, scanner, facsimile machine, external hard drive, external CD/DVD player, supplemental speakers, mouse, alternate keyboard, or video game player;
- [0315] (f) a telephone, mobile phone, PDA, or camcorder;
- [0316] (g) a key holder, writing instrument holder, eraser holder, or eye glass holder;
- [0317] (h) a stethoscope holder, personal thermometer holder, otoscope holder or any other medical instrument holder;
- [0318] (i) a cup holder or beverage container holder; and
- [0319] (j) any hand-holdable item, object, tool or instrument, whether electronic or non-electronic.

8. Electronic Device

[0320] Referring to FIGS. 81-116, electronic device 1100 is illustrated. As illustrated in FIGS. 89 and 90, electronic device 1100 has: (a) a main housing 1102 including a front housing portion 1104 and a rear housing portion 1106 which are fastened together in a shell-like fashion to define a cavity 1108; (b) a display screen 1110 supported by the main housing 1102; (c) a motherboard 1112 positioned within the cavity 1108 of the main housing 1102 behind the display screen 1110; (d) a DVD drive 1114 within the cavity 1108 of the main housing 1102; and (e) a plurality of other electronic components within the main housing 1102, such as fan 1116, antenna 1118, data storage or hard drive 1119, and electrical power unit 1121.

[0321] The main housing 1102 has a right leg 1103 and a left leg 1105. The legs 1103 and 1105 position the axis of the keyboard assembly 1126 by a designated distance. The designated distance enables the pivotable keyboard assembly 1126 to close in an upward position, where the keyboard assembly 1126 is parallel or substantially parallel to the plane of the screen 1110, as illustrated in FIG. 81.

[0322] In one embodiment, the electronic device 1100 has a touch screen layer or device 1120 attached to the screen 1110. The electronic device 1100 has: (a) a transparent cover or layer 1122 which covers the front housing portion 1104; (b) a camera assembly 1124; (c) a keyboard assembly 1126; (d) a desktop stand assembly 1128; (e) a right side panel 1130; (f) a left side panel 1132; (g) a bottom panel 1134; (h) a plurality of grips or rubber feet 1135; and (i) a plurality of speaker units 1137.

[0323] In one embodiment illustrated in FIGS. 89 and 96, each speaker unit 1137 has: (a) a plurality of inner walls 1139 of the cover 1122 which define a plurality of sound output holes; (b) sound output slot or opening 1141 defined by the housing portion 1106; (c) a speaker 1143; and (d) a liquid barrier 1145, such as a membrane, which forms a seal or barrier to block liquid from reaching the speaker 1143. In one embodiment, the liquid barrier 1145 achieves at least the IP54 seal standard.

[0324] In one embodiment illustrated in FIG. 85, the right side panel 1130 includes a fan vent 1136 and a door or slot

wall 1138 for the DVD drive 1114. In one embodiment illustrated in FIG. 86, the left side panel 1132 includes a plurality of differently sized SD card reader slots 1140; a plurality of USB ports 1142; an audio output port 1144; a microphone input port 1146; a volume adjustment dial 1148; a power button 1150; and a power lock device 1152. To lock the power, the user inserts a key (not shown) into the slot 1154 and then turns the key directed toward the lock symbol 1156. When the key is in that position, the electronic device 1100 will not power off if it is already powered on, and the electronic device 1100 will not power on if it is already powered off. To unlock the power control, the user turns the key so it is directed toward the unlock symbol 1158. In one embodiment illustrated in FIG. 87, the bottom panel 1134 covers a plurality of data ports, including serial ports, VGA port, TV tuner port, audio out port, microphone input port, and network communication ports. The bottom panel 1134 defines a plurality of openings, one of which reveals power supply 1160.

[0325] Referring to FIGS. 84 and 91-93, the camera assembly 1124 has: (a) a lens 1160; (b) a lens holder 1162 which holds the lens 1160; (c) a plurality of supports 1164 which pivotably couple the lens holder 1162 to the rear housing portion 1104; (d) an arm 1166 connected to the holder 1162; (e) a spring 1168 connected to the arm 1166; (f) a lens position controller 1168, such as a set screw, which is aligned to apply a force to the arm 1166; and (g) a rotatable grasp portion 1170 of the position controller 1168. The holder 1162 pivots in a cradle fashion relative to the supports 1164. In operation, the spring 1168 predisposes the holder 1162 to be tilted upward. As the user rotates the grasp portion 1170 clockwise, the holder 1162 pivots downward. By rotating the grasp portion 1170 clockwise or counterclockwise, the user is able to adjust the viewing angle of the lens 1160 upward or downward. The front housing portion 1106 defines an opening 1172, and the cover 1122 has a camera window 1174 with suitable optical properties. The lens 1160 is aligned with the opening 1172 and the camera window 1174.

[0326] The front housing portion 1106 also defines a plurality of additional openings 1176 which are aligned with the window 1174. In one embodiment, one or more of the additional openings 1176 are used to output light from LED light sources associated with the operational modes of the camera assembly 1124, such as camera on and camera off. In another embodiment, one or more of the additional openings 1176 receive an infrared light beam which is detected by an infrared signal receiver.

[0327] Referring to FIGS. 94-104, the keyboard assembly, in one embodiment, includes: (a) an input device having a plurality of keys or a keyboard 1178; (b) a cursor steering device or pointer 1180, which, in the illustrated embodiment, is a trackball; (c) right and left selection buttons or mouse buttons 1182; (d) a keyboard shield or keyboard panel 1184 which guards the keyboard 1178 when the keyboard is closed, adds structural strength to the main housing 1102, and blocks user accessibility to electrical and data cords and cables which may hang down from the rear of the electronic device 1100; (e) a recessed area 1186 which has the opposite configuration of the pointer 1180 so as to receive the pointer 1180 when the keyboard is closed, as shown in FIG. 81; (f) a keyboard main housing 1188 including a plurality of keyboard housing portions 1190 and 1192 which fit together in a shell-fashion; (g) a keyboard latch 1194 connected to the main housing 1188; (h) a transparent plastic cover or layer 1196 attached to the keyboard housing portion 1192; (i) a

plurality of projections, linear extensions or shaft devices 1198; and (j) a plurality of keyboard position controllers 1200, each of which is operable with one of the shaft devices 1198.

[0328] In one embodiment not illustrated, the electronic device 1100 does not have a keyboard panel 1184. In such embodiment, the main housing 1102 defines a pass-through opening below the display screen 1110.

[0329] Referring to FIGS. 90 and 97, each shaft device 1198 has: (a) a mount 1202 connected to the keyboard main housing 1188; and (b) a shaft 1204 fixedly or non-rotatably connected to the mount 1202. Referring to FIGS. 97-104, the keyboard position controller 1200 has: (a) a spring device 1206 connected to the housing portion 1104; and (b) a spring device engager 1208. In one embodiment illustrated in FIGS. 97 and 104, the spring device 1208 includes: (a) a spacer or a stack of plates 1210; (b) a retaining frame 1212 attached to the uppermost plate 1214 by a plurality of screws (not shown) which extend through the openings 1216; and (c) a support 1218 which connects the plates 1210 to the housing portion 1104. The retaining frame 1212 has a leaf spring 1220 including a protruding contact region 1222.

[0330] In one embodiment illustrated in FIGS. 97-104, the spring device engager 1208 defines an opening which receives the shaft 1204. The spring device engager 1208 has a cam device 1224 having a plurality of protrusions 1226. The spring device engager 1208 is configured to be slid or moved between a plurality of positions along the shaft 1204. Also, the spring device engager 1208 has a fixed angular position on the shaft 1204. In other words, the engager 1208 is configured to slide along the shaft 1204 without rotating relative to the shaft 1204. When the keyboard assembly 1126 is pivoted or rotated, the shaft 1204 rotates, which, in turn, causes the engager 1208 to rotate.

[0331] The slider 1228 is configured to receive and surround the cam device 1224. In one embodiment, the slider 1228 has a grasp 1230 configured for a user's grasping of the slider 1228.

[0332] An arm 1232 of the support 1218 receives the shaft 1204. The arm 1232 is configured so that it does not restrict the rotation of the shaft 1204.

[0333] In one embodiment, the keyboard assembly 1126 has a resistance device 1234 configured to produce a substantially constant resistance to the rotation of the shaft 1204. The resistance device 1234 keeps the keyboard assembly 1126 from slamming down when the latch 1194 is actuated for opening. Referring to FIGS. 97 and 99, the resistance device 1234 is an assembly of: (a) two bushings or washers (plastic washers in one embodiment) 1236; and (b) a fastener or nut 1238. The shaft 1204, in one embodiment, has a flange 1238 illustrated in FIG. 97. To generate resistance, the nut 1238 is screwed onto the threaded shaft 1204 until it squeezes, and applies a suitable force to, the washers 1236 and the flange 1238. This forces the flange 1238 against the arm 1232. Since the arm 1232 is connected to the housing 1104, the flange 1238 (and the shaft 1204) undergo a frictional force. The frictional force produces a substantially constant resistance to the rotation of the keyboard assembly 1126.

[0334] In operation, the user may open the keyboard assembly 1126 by pulling it outward from the upward, closed position shown in FIG. 81 to the downward, open position shown in FIG. 94. While opening the keyboard assembly 1126, the frictional force keeps the keyboard assembly 1126 from slamming down. As the user pivots the keyboard assembly 1126

downward, one of the protrusions 1226 of the spring device engager 1208 engages the contact region 1222 of the leaf spring 1220. The spring force of the leaf spring 1222 maintains the keyboard assembly 1126 at a set angle 1239, as illustrated in FIG. 95. In one embodiment, this angle is one hundred and two degrees from the vertical plane. If an excessive load or weight is applied to the keyboard assembly 1126, for example over twenty-five pounds of force, the spring 1222 gives way, and the keyboard assembly 1126 pivots downward with no counteractive force other than the frictional force described above. The user may then reset the keyboard assembly 1126 by pivoting it upward until the spring 1222 gives way. Accordingly, the spring-based keyboard position controller 1200 provides over-force protection for the keyboard assembly 1126. In the event of an improper force, for example, the force of someone hanging or sitting on the keyboard assembly 1126, the spring 1222 gives way rather than resulting in the bending or destruction of the mechanical parts of the electronic device 1100.

[0335] The keyboard position controller 1200 also enables the user to disengage the leaf spring 1222. This enables free pivoting of the keyboard assembly beyond the set angle 1239, subject to the frictional force of the resistance device 1234. This may be desirable when resetting the keyboard as described above. This may also be desirable when using the electronic device 1100 when it sits on a desktop 1241, as illustrated in FIG. 111. For example, the electronic device 1000 leans back by an angle 1243. This causes the keyboard assembly 1126 to be positioned above the desktop 1241 at an angle 1247 equal to angle 1243. To enable the keyboard assembly 1126 to rest flat or flush on the desktop 1241, the user can push the grasps 230 inward, toward the center of the electronic device 1100, as illustrated in FIGS. 84 and 98.

[0336] Referring to FIGS. 101, 103 and 104, the movement of each grasp 230 from a lock or set position P1 to a released position P2, moves the spring device engager 1208 so that it is out of reach of the contact region 1222 of the leaf spring 1220. Therefore, in position P2, the engager 1208 remains disengaged from the leaf spring 1222 while the user pivots the keyboard assembly 1126 downward beyond the angle 1239. In one embodiment, when the grasps 230 are in position P2, the keyboard assembly 1126 is pivotable downward more than one hundred eighty degrees from the vertical plane without any engagement with the leaf spring 1222. Therefore, the keyboard assembly 1126 is positionable to lay substantially flat and flush with the desktop 1241, as illustrated in FIG. 112.

[0337] Referring to FIGS. 105-109, the keyboard latch 1194 includes: (a) a grasp 1240 which has a finger 1241 and which defines a tool opening 1242; (b) a projection device 1244 which defines a lock opening 1246 and a coupler opening 1248; (c) a spring 1250 which biases the projection device 1244 upward; (d) a spring 1252 received by the lock screw 1254; and (e) a rack 1256 which has a plurality of grooves which mate with the rear side of the projection device 1244. The projection device 1244 has a sloped floor or ramp 1245, as illustrated in FIG. 108. The projection screw 1254 has a protrusion 1247 sized to be received by the lock opening 1246.

[0338] In operation, the spring 1250 predisposes the projection device 1244 to have an upward or extended position. Referring to FIG. 107, in the extended position, the projection device 1244 extends above the lower edge 1258 of the housing portion 1104. Accordingly, the keyboard assembly 1126 is secured closed in its upward or closed position, as shown in

FIG. 81. To open the keyboard assembly 1126, the user pulls the grasp 1240 outward, toward the user. The finger 1241 of the grasp 1240 slides along the ramp 1245. The force applied to the ramp 1245 pushes the projection device 1244 downward until the projection device 1244 recedes below the lower edge 1258 of the housing portion 1104. Accordingly, the ramp 1245 functions as a translator which translates horizontal movement of the grasp 1240 to vertical movement of the projection device 1244. The user may further pull the grasp 1240 to pivot the keyboard assembly 1126 outward to its open position, as illustrated in FIG. 94.

[0339] When the keyboard assembly 1126 is in the upward, closed position, as illustrated in FIG. 81, the user may desire to lock or secure the keyboard assembly 1126 in that closed position. To do so, the user may insert a tool, such as a screw driver, through the tool opening 1242. Then, the user may rotate the projection screw 1254 ninety degrees in either direction. The protrusion 1247 blocks the projection device 1244 from traveling downward. Therefore, if one were to pull the grasp 1240 outward, the projection device 1244 would not move downward, and the keyboard assembly 1126 would remain locked or secured closed.

[0340] Referring to FIGS. 83 and 111-116, the desktop stand assembly 1128 includes: (a) a stand 1260 having a substantially U-shaped configuration; (b) a stand latch 1262 connected to the housing portion 1104; and (c) a plurality of coupler assemblies 1264. The stand 1260 has a foot section 1262. The foot section 1262 defines: (a) a latch opening or latch recess 1266; (b) a plurality of arc-shaped grasp regions 1268 configured for relatively comfortable finger and hand engagement; and (c) a plurality of feet grips 1270 of a rubber or other suitable material.

[0341] The stand latch 1262 includes: (a) a slider grasp 1272; (b) a support 1274 which connects the slider grasp 1272 to the housing portion 1104; and (c) a spring 1276 which biases the slider grasp 1272 to have a predisposed extended position, as illustrated in FIG. 113.

[0342] As illustrated in FIGS. 114-116, each coupler assembly 1264 includes: (a) a support 1278 connected to the housing portion 1104, wherein the support 1278 defines an opening; (b) a shaft 1280 inserted through the opening of the support 1278; (c) an annular spacer 1282 which receives the shaft 1280; (d) a spring 1284; and (e) a depressible coupler 1286. The spring 1284 biases the depressible coupler 1286 to have a predisposed position pressed within the cavity 1288 defined by the joint 1290.

[0343] The depressible coupler 1286 has a tube or hollow shaft 1292 configured to receive the shaft 1280. The interior surface of the hollow shaft 1292 has a non-cylindrical shape. The exterior surface of the shaft 1280 has a non-cylindrical shape configured for mating with the hollow shaft 1292. When the shaft 1280 is inserted into the hollow shaft 1292, the shafts 1280 and 1292 have a fixed angular position so that the rotation of the shaft 1292 causes rotation of shaft 1280.

[0344] The joint 1290 has a protrusion 1294 within the cavity 1288, as shown in FIG. 116. The coupler 1286 has a collar 1296 which defines a plurality of slot walls 1298. Each slot wall 1298 is configured to mate with, engage, and receive, the protrusion 1292.

[0345] The following steps or method enable the desktop stand assembly 1128 to be opened:

[0346] (a) slide the slider grasp 1272 upward;

[0347] (b) pull the foot section 1262 slightly outward;

[0348] (c) push both couplers 1286 inward so that none of the slot walls 1292 are mated or engaged with the protrusion 1294;

[0349] (d) while maintaining the couplers 1286 pushed inward, pull the stand 1260 outward until the foot section 1262 is near to the desktop 1241 (or otherwise adjacent to the bottom end 1300 of the electronic device 1100); and

[0350] (e) release the depressible couplers 1286 and slightly pivot the stand 1260 back and forth until the springs of the couplers 1286 pop the slot walls 1292 into position to receive the protrusions 1294.

[0351] The user may then lean the electronic unit 1100 backward for positioning and use on the desktop 1241, as illustrated in FIG. 112.

[0352] The stand 1260 also functions as a carrying handle when the stand is in its upward, closed position. One method for carrying the electronic device 1100 is to grab the grasp regions 1268 of the stand 1260. The housing portion 1104 defines a hand recess 1302, illustrated in FIG. 83, which receives a portion of the user's hand while the user's hand is holding the grasp regions 1268.

[0353] As illustrated in FIGS. 84 and 95, the rear housing portion 1106 has a plurality of wall mount screw anchors 1304 arranged in a VESA 75 mm hole pattern and a VESA 100 mm hole pattern. The wall mount screw anchors 1304 are configured to receive a plurality of screws 1306. In one embodiment, screws 1306 are configured to fasten a suitable wall mount plate or device 1308 to the rear housing portion 1106. The wall mount device 1308 may, in turn, be used to mount the electronic device 1100 to a wall or other upstanding structure 1310 using screws 1312.

[0354] The rear housing portion 1106 has a plurality of grip or traction regions 1314. The traction regions define a ridges or friction increasers which facilitate handling of the electronic device 1100.

[0355] The electronic device 1100 defines at least one peripheral hole pattern 1316, as illustrated in FIG. 84. The hole pattern 1316 is configured to receive screws which, in turn, are connected to a peripheral, such as a magnetic swipe card reader, slot optical card reader or any other suitable peripheral. In one embodiment not shown, the main housing 1102 houses or holds an optical code reader (such as a bar code reader), a printer, a scanner, a biometry reader or any other suitable input or output device.

[0356] In one embodiment, the keyboard 1178 and the entire front of the electronic device 1100 are sealed from liquid penetration at least to satisfy the IP54 standard. In one embodiment, one or more gaskets or seals are incorporated into the housing 1102 to form a liquid seal for the screen 1110, speakers 1105 and electronic components of the keyboard 1178. In one embodiment, the keyboard housing 1188 defines one or more drain holes to enable liquid to drain from the keyboard housing 1188.

[0357] Additional embodiments include any one of the embodiments described above, where one or more of its components, functionalities or structures is interchanged with, replaced by or augmented by one or more of the components, functionalities or structures of a different embodiment described above.

[0358] It should be understood that various changes and modifications to the presently preferred embodiments described herein will be apparent to those skilled in the art. Such changes and modifications can be made without depart-

ing from the spirit and scope of the present invention and without diminishing its intended advantages. It is therefore intended that such changes and modifications be covered by the appended claims.

The invention is claimed as follows:

1. An electronic device comprising:
 - a main housing defining a cavity;
 - a display screen supported by the main housing;
 - a motherboard positioned within the cavity behind the display screen; and
 - a keyboard assembly supported by the main housing, the keyboard assembly having:
 - (a) a keyboard housing having a plurality of ends;
 - (b) a plurality of shafts, each one of the shafts coupled to one of the ends; and
 - (c) at least one keyboard position controller having:
 - (1) a spring device coupled to the main housing, the spring device having a contact portion;
 - (2) a spring device engager coupled to the at least one shaft, the spring device engager configured to be:
 - (i) engaged with the contact portion when the keyboard is subject to a first force; and
 - (ii) disengaged from the contact portion when the keyboard is subject to a greater, second force.
2. The electronic device of claim 1, wherein the at least one keyboard position controller has a resistance device configured to produce a resistance to a rotation of the at least one shaft.
3. The electronic device of claim 2, wherein the resistance device includes: (a) a support coupled to the main housing, the support defining an opening which receives a portion of the at least one shaft; (b) an extension coupled to the at least one shaft; and (c) a fastener configured to apply a force to press the extension against the support.
4. The electronic device of claim 1, wherein the spring device engager has a cam device coupled to the at least one shaft, the cam device having at least one protrusion which moves with a rotation of the at least one shaft, the protrusion being movable between: (a) a first position in which the protrusion is engaged with the contact portion; and (b) a second position in which the protrusion has moved past the contact portion and is disengaged from the contact portion.
5. The electronic device of claim 1, wherein the spring device engager: (a) has a first angular position when the keyboard is subject to the first force; (b) has a second angular position when the keyboard is subject to the second force; and (c) is configured to be moved relative to the at least one shaft between: (i) a first adjustable position associated with a keyboard set mode, wherein the spring device engager is positioned to be brought into engagement with the contact portion when the spring device engager has the first angular position; and (ii) a second adjustable position associated with a keyboard release mode, wherein the spring device engager is positioned to be disengaged from the contact portion when the spring device engager has the first angular position.
6. The electronic device of claim 5, which includes a grasp coupled to the spring device engager, the grasp extending through an opening defined by the main housing, the grasp being movable between: (i) a first grasp position associated with the keyboard set mode; and (b) a second grasp position associated with the keyboard release mode.
7. The electronic device of claim 1, wherein: (a) the main housing defines a latch space; and (b) the keyboard assembly has a keyboard latch, the keyboard latch including: (i) a latch

grasp; (ii) a latch spring coupled to the latch grasp; and (iii) a male member configured to be movable into and out of the latch space.

8. The electronic device of claim 7, wherein the keyboard latch has a latch set device which is operable to set the keyboard latch in a closed mode, wherein the male member is positioned within the latch space when the keyboard latch has the closed mode.

9. An electronic device comprising:

- a main housing defining a cavity;
- a display screen supported by the main housing;
- a motherboard positioned within the cavity behind the display screen; and
- a camera assembly supported by the main housing, the camera assembly having:
 - (a) a camera having a lens,
 - (b) a lens holder which holds the lens of the camera, the lens holder being movably coupled to the main housing; and
 - (c) a lens position controller which is adjustable to cause movement of the lens holder.

10. The electronic device of claim 9, wherein the lens holder is pivotably coupled to the main housing.

11. The electronic device of claim 9, wherein the camera assembly has a spring coupled to the lens holder.

12. The electronic device of claim 9, wherein a portion of the lens position controller is a camera adjustment grasp.

13. The electronic device of claim 12, wherein the main housing has a rear side, the rear side defining a camera adjustment grasp opening configured to receive the camera adjustment grasp.

14. An electronic device comprising:

- a main housing defining a cavity;
- a display screen supported by the main housing, the main housing having a rear side, the rear side having an upper rear side;
- a motherboard positioned within the cavity behind the display screen; and
- a desktop stand assembly supported by the main housing, the desktop stand assembly having:
 - (a) a stand having a foot portion;
 - (b) at least one stand coupler unit which pivotably couples the stand to the main housing so that the stand is pivotable between
 - (i) an upward position in which the foot portion is adjacent to the upper rear side of the main housing; and
 - (ii) a downward position in which the foot portion is engaged with a support surface.

15. The electronic device of claim 14, wherein the desktop stand assembly has a stand latch coupled to the main housing, the stand latch being configured to secure the stand in the upward position.

16. The electronic device of claim 14, wherein: (a) the stand has a coupling wall, the coupling wall defining: (i) an opening; and (ii) a protrusion.

17. The electronic device of claim 16, wherein the stand coupler unit has a position setter coupled to the main housing, the position setter having a protrusion engager, the position setter being movable between: (a) a first position in which the protrusion engager is engaged with the protrusion; and (b) a second position in which the protrusion engager is disengaged from the protrusion.

18. The electronic device of claim 17, wherein: (a) the stand coupler unit has: (a) a housing coupler which is coupled to the housing; and (c) the position setter has a stand coupler

configured to mate with the housing coupler so that the housing coupler has a fixed angular position relative to the stand coupler.

19. The electronic device of claim **18**, wherein the stand coupler unit has a spring configured to bias the position setter to have the first position.

20. The electronic device of claim **15**, wherein: (a) the foot portion defines an opening; and (b) the stand latch has a protrusion and a spring configured to bias the protrusion to project into the opening.

* * * * *